

PAPER • OPEN ACCESS

Assessment of the volume and material container influence on juice cooling process

To cite this article: A Suman *et al* 2022 *IOP Conf. Ser.: Earth Environ. Sci.* **1106** 012011

View the [article online](#) for updates and enhancements.

You may also like

- [Determination of caffeine content in tea beverages](#)
Jianbin Shao and Yiping Zhang
- [The development of a functional adaptogenic beverage, using plant extracts of Centella asiatica and Hoodia gordonii](#)
A R Khasanov, N A Matveeva and A A Gruzd
- [Bottled water quality and associated health outcomes: a systematic review and meta-analysis of 20 years of published data from China](#)
Alasdair Cohen, Jingyi Cui, Qingyang Song *et al.*

PRIME
PACIFIC RIM MEETING
ON ELECTROCHEMICAL
AND SOLID STATE SCIENCE

HONOLULU, HI
October 6-11, 2024

Joint International Meeting of
The Electrochemical Society of Japan (ECSJ)
The Korean Electrochemical Society (KECS)
The Electrochemical Society (ECS)

Early Registration Deadline:
September 3, 2024

**MAKE YOUR PLANS
NOW!**

Assessment of the volume and material container influence on juice cooling process

A Suman^{1,*}, N Zanini¹, R Friso¹, M Pinelli¹, and L Bottos²

¹ Department of Engineering (DE), University of Ferrara, 44122 Ferrara ITALY

² Sidel S.p.a., 37139 Verona ITALY

* Corresponding author e-mail: alessio.suman@unife.it

Abstract. The quality of bottled beverages depends on the thermal process they undergo during the bottling process. The thermal history of the bottled beverage impacts the conservation of the product itself indeed. The temperature variation is related to specific aspects, such as the thermophysical properties, the heat exchange regime, and the possible simultaneous presence of more phases in the beverage itself. For instance, the behavior of the fluid inside the container might change according to the percentage of solid phases (e.g., pulp for juices). The present work addresses the cooling process on a processing line for beverage containers. This process aims to reduce the fluid temperature to preserve organoleptic characteristics and allows a stable and safe storage phase. The analysis has been carried out with a purpose-designed test bench to mimic the cooling process. Two juices with different percentages of solids (15 % and 50 %) are investigated for two container volumes (250 ml and 330 ml) and two container materials (glass and aluminum). The results show the influence of the pulp content on the cooling performance. The changes in the heat transfer performance determine different outlet temperature values and a different sensitivity to the container characteristics.

1. Introduction

The modern food industry is based on the capability to produce a considerable amount of food efficiently and safely. Energetic and sanitary rules are even stricter, and the necessity of reducing emissions and incrementing the food shelf life is even more stringent. In this framework, the analysis and the improvements of the thermal process in food processing are the basis for a more efficient production plant and safer processed food. Specifically, the food conditioning systems (refrigeration, drying, pasteurization, cooking, and cooling) have crucial importance in assessing the final quality of the food product and the container (considering the storage and labeling process) [1]. The primary thermal process is pasteurization, which is the strategy to extend the microbiological stability of food. Proper food temperature control is mandatory even after pasteurization due to the need to control the food's shelf life, ensuring the products' taste and organoleptic characteristics.

Higher production plants are usually based on continuous processes carried out by using tunnel machines. Tunnel machines imply water sprays used to heat or cool the filled containers, which a conveyor carries from the load station to the discharge section of the tunnel. Therefore, the container moves continuously under the water spray following the thermal cycle imposed by the latter ones. The water spray is composed of several zones that differ by the temperature of the water spray. The conveyor translational velocity is driven by the production requirements. Therefore, the tunnel machines have to be designed to ensure the proper production capability and the thermal cycles of the filled container. In addition, to increase the capacity of the production plan and its flexibility, the same tunnel machine has to be capable of performing the thermal process for different food products and different containers [2, 3]. Due to this, at the design stage, the thermal capability of the tunnel machine has to be known a priori,



and for this reason, the heat exchanger capability of the filled container has to be understood. The heat transfer process is based on the water spray that impinges the container and forms a film capable of heat-up or cool-down the food inside the container [4 – 6]. The internal cooling of the container depends on the container and fluid characteristics. The internal heat transfer is driven by the natural convection based on the formation and development of the convective cell driven by the local density value [7 – 9]. As reported in the literature [10, 11], according to the food characteristics, the internal heat transfer process is guided by the fluid characteristics, which determine if the heat exchange is governed by the conduction and/or convective mechanisms [12]. A solid fraction in the fluid causes the modification of the shear rate/shear stress relation, determining a non-Newtonian behavior, which implies the change of the convective cell development. Moving to higher pulp content (i.e., higher viscosity), the internal heat exchange is progressively driven by conduction instead of convective mechanisms proper to a low-viscosity medium.

In this paper, a sensitivity analysis of the heat transfer performance of fruit juices and containers is carried out by means of an experimental campaign performed on an *ad hoc* designed test cell. The analysis refers to the thermal process of a cool-down thermal treatment of two fruit juices that differ in the pulp content (15 % and 50 %). To account for the container influence on heat transfer, two container materials (glass and aluminum) and two container volumes (250 ml and 330 ml) have been considered. The paper presents an original cross-correlation analysis of fluid characteristics and containers by comparing fruit juices and water behavior. The combination of food products and the container is the basis for improving the design capability of food processing tunnel machines.

2. Materials and methods

The analyses reported in this work deal with the behavior of the heat exchange processes on different food products and containers. In this section, the thermal process, the experimental test cell, the considered food products, and the experimental strategy are described in detail.

2.1. Cooling process

The heat exchange process is of paramount importance in characterizing a fruit juice production plant. In particular, this analysis focuses on the thermal cooling process carried out after the filling operation. Typically, fruit juices are prepared and heat-treated in containers to define the proper mixture (water, pulp, sugar, chemical additives, etc.) and complete the adequate pasteurization process. After this step, the fruit juice is transferred to the filler machine responsible for the filling process of bottles/containers. This continuous process picks up, fills, and releases the container to the conveyor belt. These readily filled containers are then transferred to the cooler machine, which is designed to cool down the products within a scheduled interval time to preserve the organoleptic characteristics of the juice, reaching the target temperature for the subsequent storage phase (usually lower than 45 °C). The cooler machine has a tunnel configuration to guarantee a continuous process from the filler to the packaging machine. The cooler tunnel, similar to a pasteurization machine [2, 13, 14], realizes the cooling process through water spraying. It is divided into several zones according to the water temperature that has to cool down the product. This cooling process consists of two heat transfer mechanisms: a water droplet impingement and a water film-based heat exchange, both mediated by the container surface. The translational velocity of the conveyor belt continuously drives the process. As a result, the product temperature value is reduced from the filling station through the cooler machine zones, defined according to the water temperature. Usually, the water temperature of two subsequent zones does not differ by more than 10 °C. Therefore, for each juice, a specific thermal process characterized by a specific number of zones, shower temperature, and duration (i.e., tunnel length coupled with the conveyor velocity) has to be set up. In addition, the management of the cooler machine to match the juice requirement passes through the comprehension of the juice thermal behavior and machine characteristics.

In this investigation, a representative thermal cycle was chosen considering common values of starting and ending temperature, zone duration, and the number of zones. In particular, the cooling process was designed with four zones, with a shower temperature of 58 °C, 49 °C, 40 °C, and 31 °C,

from the first to the fourth zones, respectively. The temperature steps are designed to have a uniform cooling process (almost 10 °C for each step) starting from an initial temperature difference between juice and water nozzles of 20 °C. Furthermore, the duration of each zone is set equal to 300 s. Using the representative fixed time duration for each zone allows the direct comparison of thermal fluid behavior in terms of temperature, making the time duration zone (that is, in an actual application, a variable) a constant parameter in the present investigation.

The experimental tests were realized on a specific test cell able to reproduce the actual condition of a cooler machine. The test cell represents a portion of an existing tunnel machine with a footprint dimension of 2 m x 2 m and 3.5 m-height. A cooler machine comprises multiple rows of spray nozzles generated by a specific nozzle. The pitch and number of nozzles are the same as the actual tunnel machine used. The containers are positioned under the nozzles and supported by a perforated floor which is a portion of the actual PVC conveyor belt. To supply the temperature-controlled water to the heat-treatment zone, the test cell was equipped with four different water tanks kept at fixed temperature values determined after the design process of the cooling cycle. The temperature-controlled water was supplied to the nozzle rows by a centrifugal pump, and the flow rate was kept constant by a throttle valve positioned before the nozzle distributor. The schematic representation of the test cell and the actual installation are reported in Fig. 1.

2.2. Food products and containers

The present analysis is based on the cooling process of two different products. In particular, two fruit juices have been considered. Figure 2 reports the nameplate characteristics of the banana and the pear juices analyzed in the experimental tests. Both samples are taken from a local market since they are commercially available. The banana juice is produced by Maaza (a registered trademark of Infra Foodbrands BV, Amsterdam, The Netherlands), while pear juice is made by Yoga (Conserve Italia SOC.COOP.AGRICOLA – San Lazzaro di Savena, Bologna, Italy). The selection of these two food products is related to the possibility to discover the differences in the heat transfer behavior of non-Newtonian food fluids characterized by a viscosity greater than water. To increase the reliability and usefulness of the results reported in the present investigation, physical and rheological characterizations have been done. The commercially available products used for the current experimental tests are already thermally treated, and they could not perfectly match the characteristics of the raw products that characterized the actual cooler operation. According to the nameplate data, the selected fluids are characterized by 23 % and 50 % pulp content for the banana and pear samples, respectively. In addition to these data, a preliminary characterization of density and Brix degree were carried out. Banana juice has a density of 1046 kg/m³ and a Brix degree of 14 °Bx. Pear juice has a density of 1043 kg/m³ and a

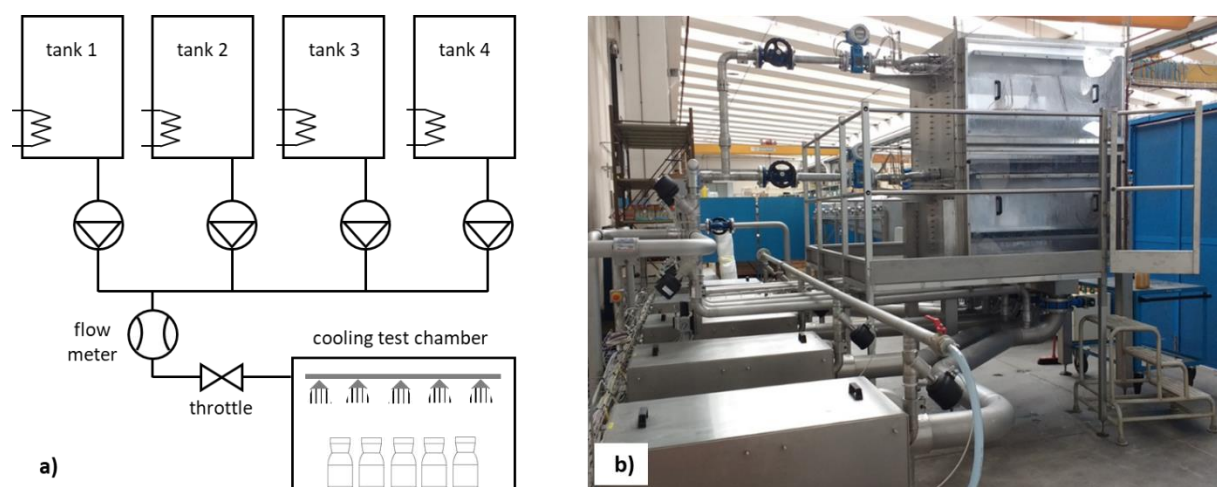

Figure 1. Experimental test cell: a) sketch of the test bench, and b) actual installation.

Brix degree of 14.4 °Bx. It can be noted that the two juices show similar density and Brix degree values instead of different pulp content. Figure 2 reports the rheological characteristics of the juices. Rheological data were obtained with the rotational rheometer TA Instruments AR 2000 ex equipped with 60 mm acrylic parallel plates (for the tests @ 20 °C) and 40 mm stainless steel plates (for the tests

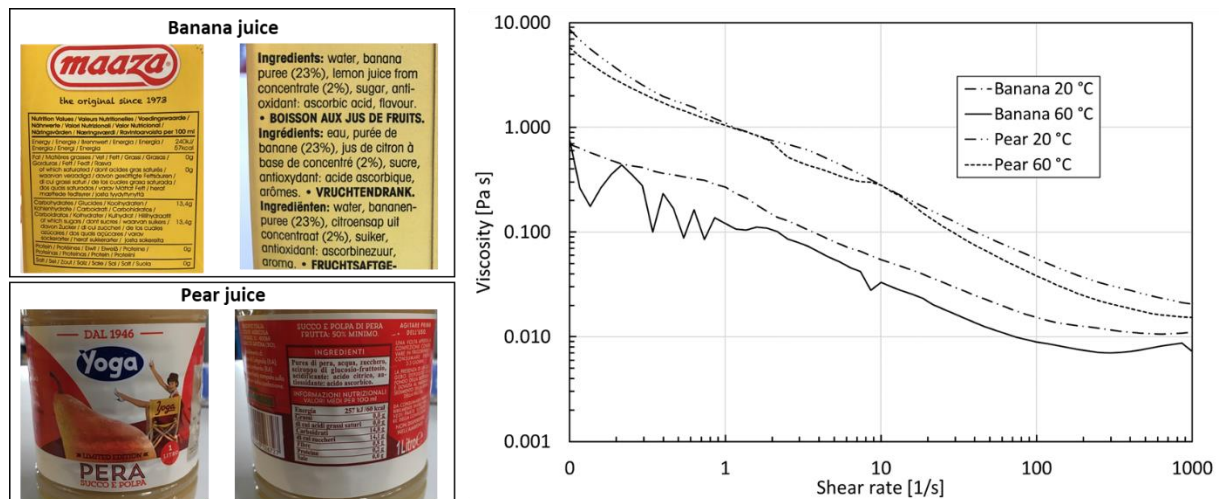

Figure 2. Nameplate and rheologic characterization.

@ 60 °C). The gap between the two plates was set to 1.5 mm. The tests were accomplished under continuous flow conditions, while flow curves were obtained by changing the shear rate from 0.1 s^{-1} to 1000 s^{-1} . The fluid temperature was monitored during rheological tests and kept equal to 20 °C and 60 °C. Both fluids show only a slight variation of the rheological properties moving from 20 °C to 60 °C, thus avoiding the influence of the modification of the viscosity behavior during the cooling test.

The containers depicted in Fig. 2 are representative of the ones used in the present investigation. Two volumes and two materials are selected to analyze the heat exchange behavior, highlighting the influence of container volume and material on the cooling process. Figure 3 shows the container used and reports the shapes of each of them. The selected volume values are 250 ml and 330 ml for glass and aluminum containers. Figure 3 shows the temperature probe position used in the experimental tests. The probes used are a T-type thermocouple mineral insulated with a steel sheath (sheath diameter equal to 1 mm). Each thermocouple is placed in correspondence to the container axis and fixed at a specific height from the bottom. In particular, two points are monitored during the thermal process named as a cold spot and a middle spot. The cold spot detection point is the location usually used by manufacturers to monitor the thermal behavior during the pasteurization process. It is recognized as the coldest region of the container (i.e., the cold spot represents a safe detection point because it is the region with the lowest pasteurization unit value). Usually, it is positioned at 1 in (0.0254 m) from the container bottom, independently of the container volume and shape. However, in the present case, due to the thermal process (cool-down operation), the cold spot does not represent the actual safest behavior of the container. For this reason, the middle spot is added to the thermal detection. The position of the middle spot is dependent on the container volume and shape. The purpose of using the middle spot is to monitor the thermal behavior in the container center as a representative point of the container mass. As reported in the open literature, the position of the slowest cooling zone is usually located at 75 % to 80 % of the container height. However, by increasing the fluid viscosity, the slowest cooling zone tends to be near the geometric center [15, 16]. Looking at the literature result and considering the viscosity for the lower shear rate values reported in Fig. 2, the selection of the middle spot can be considered reliable to represent the thermal cycle for the selected juices.

2.3. Experimental strategy

The cooling tests were carried out by following a specific strategy to ensure the repeatability of the results. In particular, four independent tests were carried out for each test condition identified by fluid, container volume, and container material. The position of the samples under the nozzle spray is taken according to [7] to avoid the influence of the spray direction and intensity on the heat exchange process. The sample preparation consists of the mixing operation of a certain juice volume proper to fill four samples. This process is of main importance to ensure the best uniformity in terms of fluid characteristics. After this, the heating process was carried out by immersing the container in a hot water

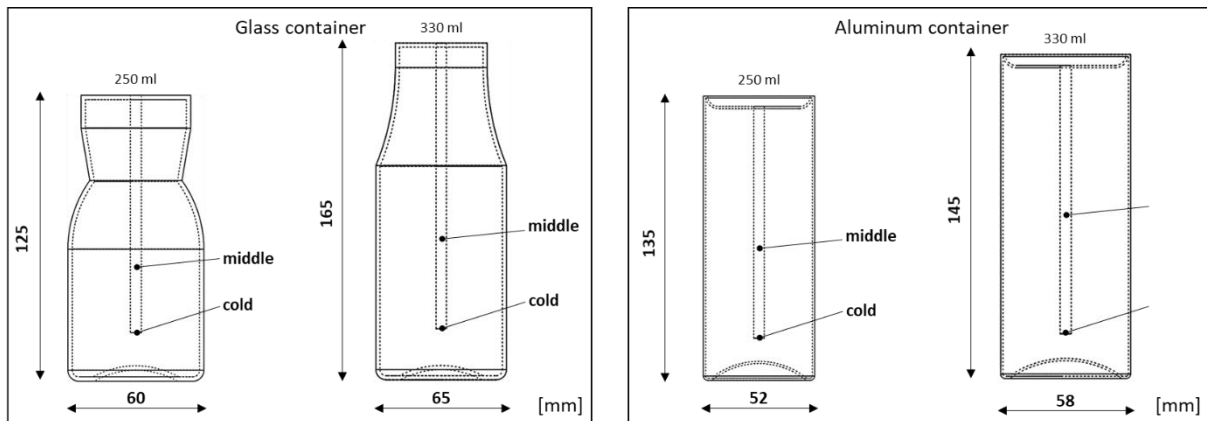

Figure 3. Container shapes, dimensions, and probe positions (probe holder is fixed at the top).

bath, providing a continuous mixing process inside the container, and avoiding the separation of pulp and water fractions. The heating process was kept constant up to a uniform temperature of juices of 85 °C. After the heating process, the sample was equipped with the sealing lead that holds the temperature probes correctly (see Fig. 3). A similar procedure was adopted for the fifth sample, filled with water representing the reference sample. The cooling procedure starts after the sealing process of the samples with the aforementioned temperature steps.

During the cooling process, the shower water temperature and the internal temperature of the samples (four samples of juice and water) were acquired every 2 s over the entire test duration (20 min). Concerning the recorded temperature, the heat transfer process was evaluated according to

$$K = \frac{60}{t_{zone}} \times \ln \left(\frac{T_{start,i} - T_{nozzle}}{T_{end,i} - T_{nozzle}} \right) \times 1000 \quad (1)$$

in which the zone duration t_{zone} is a fixed term equal to 300 s, while the temperature values are estimated with the reference of the acquired data. In particular, $T_{start,i}$ indicates the temperature of the food product (juice or water) at the beginning of the zone (i.e., at the beginning of the cooling process of reference zone i). At the same time, $T_{end,i}$ represents the temperature of the food product (juice or water) at the end of the zone (i.e., at the end of the cooling process of the reference zone i). The temperature of the nozzle spray is named T_{nozzle} , and it is kept constant over the time duration of the zone. The definition of the variable K is based on the adimensional temperature proposed by Lewicki et al. [7], which represents the instantaneous estimation of the temperature difference between the food product and the reference temperature. The latter represents the water temperature of the spray used to heat or cool food products. Equation 1 estimates the heat transfer process considering the food temperature at the start and the end of the zone. Therefore, after each cooling test, the variable K has been evaluated for the juice samples (K_j) and for the water sample (K_w) to determine the K_{ratio} as

$$K_{ratio} = K_j / K_w \quad (2)$$

which estimates how much the heat exchange process in the juice and water samples differs.

3. Results

The analysis of the results is divided into two parts related to investigating the temperature trend and examining the post-processed data. The outcomes are treated in terms of K_{ratio} to show the effects of the juice characteristics, container volume, and material.

3.1. Temperature trends

Figures 4 and 5 show the temperature variation over the cooling test duration in correspondence to the cold and the middle spots of the containers. Each graph shows seven trend lines that refer to the temperature of the cold and middle spots of the banana (2 trends) and pear juice (2 trends) samples and the water sample (2 trends). The seventh trend is the temperature of the water supplied to the nozzle spray. In the graph, the division into the four cooling zones was provided by the reference lines. The first evidence is related to the temperature detection of the middle spot in correspondence with the first cooling zone. As reported in Figs. 4, 5, the middle spot of the pear samples shows an increasing temperature trend due to the non-ideal mixing process obtained at the end of the heating phase. This thermal issue, coupled with the inertia of the pear product, generates an initial increasing temperature trend in the pear samples. In the actual installation, the filling process is carried out at a constant temperature and, in addition to the mixing process, allows a greater uniformity of the temperature inside the container. This phenomenon can also be visible in the banana samples at the beginning of the cooling test. The higher viscosity of the pear juice implies greater inertia which also characterizes the rest of the cooling procedure. Looking at the trends, it can be asserted that the fluid viscosity (which is strictly related to the pulp content) determines the inertia of the fluid to follow the spray temperature. Water samples react to the modification of the shower temperature very rapidly, and the temperature of the water sample is the closest to the one that characterized the water spray. Banana and pear juices show a delay, and the sensibility to the shower temperature is reduced by moving from banana to pear samples. In addition to the thermal inertia, the effect of the higher viscosity can be visible by looking at the temperature difference between the cold and middle spots for the 330 ml containers (see Fig. 5). The cold spot is located in the bottom region of the container (see Fig. 3), close to the bottom surface. In this location, the thermal inertia is lower than the one that characterizes the middle spot. Therefore, by detecting the temperature in the center of the container, the thermal inertia, and thus the juice temperature, could be very different from the one that characterized the cold spot. The higher the viscosity and the container volume, the greater the temperature deviation between cold and middle spots.

In addition, the temperature detection used in the sample shows that the higher viscosity determines a greater temperature difference within the same sample as the results of a heat exchange process based on the conductive instead of the convective heat transfer mechanism. Looking at the literature [12], estimations on the heat penetration into the container can be found. These findings show a different heat

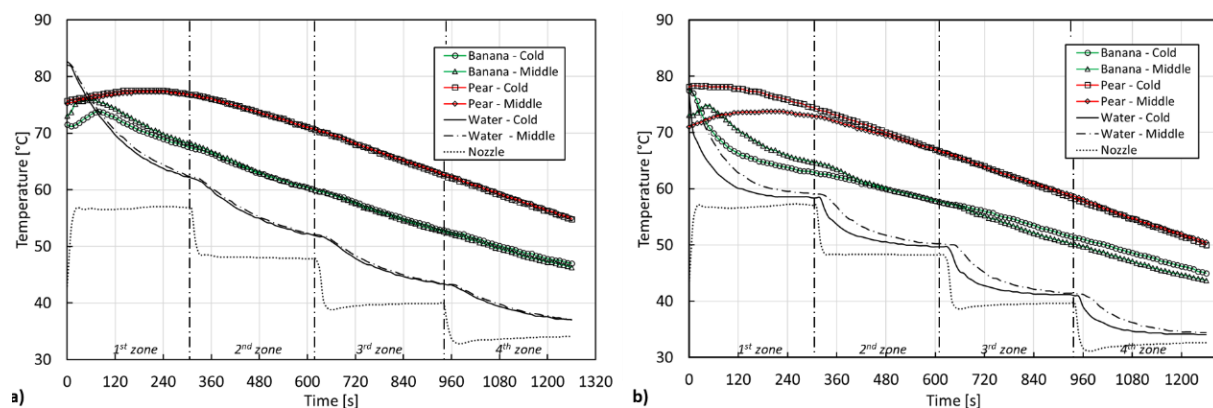

Figure 4. Temperature trends for 250 ml containers: a) glass and b) aluminium

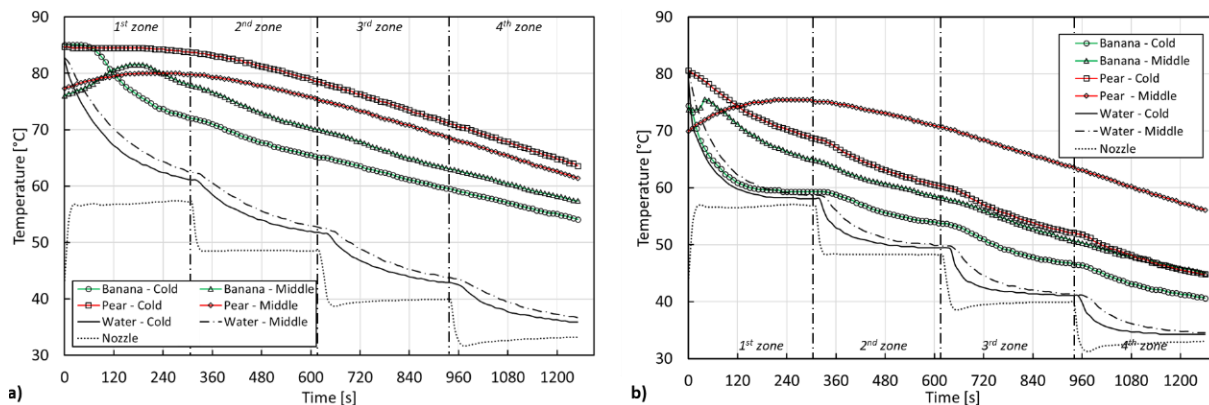

Figure 5. Temperature trends for 330 ml containers: a) glass and b) aluminum

transfer process according to the capability of the fluid to generate a convective cell. Therefore, higher viscosity fluids, or in other words, fluids with higher pulp content, seem characterized by a conduction process that is less effective in terms of heat transfer efficiency.

Final considerations about the temperature trends are devoted to the container volume and material influence. For the same material, a higher container volume leads to a more significant deviation between the samples and shower temperature. Furthermore, this deviation increases according to the fluid viscosity (see the pear samples in Figs. 4 and 5). Finally, the influence of the material can be appreciated by looking at the water temperature trends. For example, aluminum containers (Fig 4b and 5b) have greater conductivity than glass containers. Therefore, the temperature trends of the water sample are closer to the spray temperature than the ones observed for the glass containers. Thus, the non-linear combination of pulp content (i.e., fluid viscosity) and the container characteristics determine a specific and not-predictable behavior of the food temperature during a thermal process.

3.2. Sensitivity analysis of heat exchange process according to the fluid and container characteristics

The heat exchange analysis of the juice container as a function of the fluid and container characteristics has been carried out according to the aforementioned definition reported in Eq. 2. Figures 6 and 7 report the K_{ratio} values for the glass and aluminum containers, respectively. In addition, the K_{ratio} values are proposed for the cold and the middle spots. The ratio presented in Eq. 2 shows the difference in the heat exchanged with respect to the water. In other words, $K_{ratio} = 1$ represents the condition in which the sample is identical to the water in terms of the heat exchanger process. Looking at Figs. 6 and 7, it can be seen that the heat transfer process in the juice samples is far from that of the water. The K_{ratio} maximum values are reached at the end of the cooling process (4th zone) with the greatest value of 0.8. The first three zones are characterized by lower values because, at the beginning of the cooling process, the heat transfer mechanism is driven by conduction, while moving towards the last zone, the convection increases its influence, increasing the heat transfer capability. As reported in the graphs, the K_{ratio} could

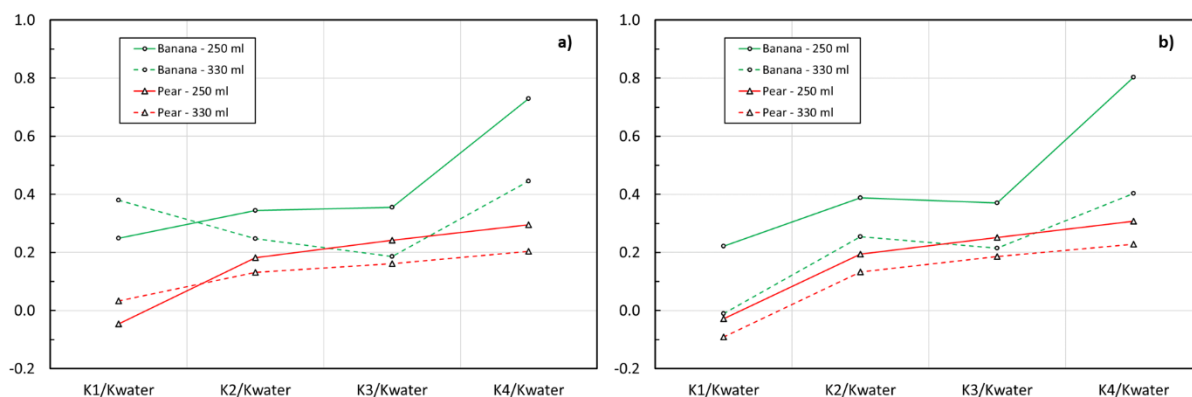

Figure 6. The K_{ratio} values for the glass container: a) cold and b) middle spots.

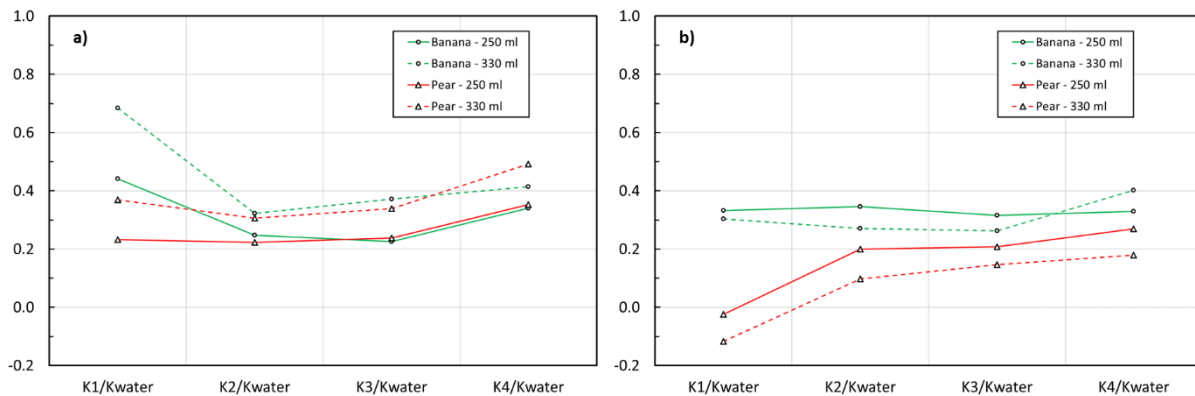

Figure 7. The K_{ratio} values for the aluminum container: a) cold and b) middle spots.

assume negative values in the first zone. This is due to the different temperature trends between the juice sample and water. When the juice temperature at the end of the reference zone is higher than the temperature of juice at the beginning, the K_j results in negative values, and at the same time, K_{ratio} becomes negative (see Figs. 4 and 5 for clarity).

The water sample has the same container of the juices, which means that the differences between the samples of 250 ml and 330 ml are due to the non-linear fluid characteristics. For example, looking at the glass container, the banana sample shows K_{ratio} values greater than the ones of pear juice, and at the same time, the samples with 250 ml show higher values than the 330 ml samples. These results imply that the heat exchange process and the capability of the cooler machine to cool down the product properly depends on the combination of fluid rheological behavior and container volume.

The influence of the container material can be visible by comparing the trends reported in Figs 6 and 7. The K_{ratio} values show that aluminum containers reduce the impact of fluid viscosity. As a result, the values shown in Fig. 7 are slightly greater than those reported in Fig. 6. In terms of trend, the K_{ratio} trends appear similar for the two materials, considering the different shapes that characterize the container. In fact, aluminum containers are characterized by a lower footprint area and higher height for a given volume. This means that the aluminum container offers a greater surface to the water spray.

4. Conclusions

In this paper, an experimental investigation of the heat transfer process of juices was proposed. The analysis refers to the cooling procedure that implies cooling down the juice containers after the filling process and before the labeling and storage phases. The investigation was carried out by considering two juices with different pulp content and thus rheology, two container materials (glass and aluminum), and two container volumes (250 ml and 330 ml).

The thermal analysis has shown that the fluid rheology determines the thermal inertia of the juice sample: higher pulp content means higher juice thermal inertia, and for higher pulp content, the juice offers the highest thermal inertia. The container volumes and materials influence the heat transfer and the temperature trends over time. In particular, the combination of the fluid rheology with the container characteristics determines a temperature trend that is difficult to be predicted due to the non-linear effects of the container and the fluid characteristics. A greater viscosity implies a considerable reduction in the heat transferred. For the most viscous juice, the heat exchange is reduced by order of magnitude with respect to the water samples.

To summarize, the higher the pulp content, the slower the heat exchanger process and the greater sensitivity to the container volume. In addition, the temperature detection used in the sample shows that the higher viscosity determines a greater temperature difference within the same sample as the results of a heat exchange process based on the conductive process instead of convective, which is responsible for a slower heat transfer process that determines the modification of the tunnel machine design. Connecting the present results with an actual production plant, some perspectives can be defined to manage the thermal inertia or the related effects. The basic principle is to allow the transition from the conductive to the convective heat exchange process. Therefore, a more representative thermal condition of the product can be obtained by shaking the container at the end of the cooling process. This procedure can effectively uniform the product temperature, allowing the mixing process between the colder fluid portion located close to the container wall and the hotter portion located in the container core.

5. References

- [1] Van Boekel M, Fogliano V, Pellegrini N, Stanton C, Scholz G, Lalljie S, Somoza V, Knorr D, Jasti P R and Eisenbrand G 2010 *Mol. Nutr. Food Res.* **54**, 1215-47
- [2] Dilay E, Vargas J V C, Amico S C, Ordonez J C 2006 *J. Food Eng.* **77**, 500-13
- [3] Derossi A, De Pilli T, La Penna M P and Severini C 2013 *J. Food Process Eng.* **36**, 211-19
- [4] Abdul Ghani A G, Farid M M, Chen X D and Richards P 1999 *J. Food Eng.* **41**, 55-64
- [5] Erdogdu F and Tutar M 2011 *J. Food Sci.* **76**, pp. E119-29
- [6] Bhuvaneswari E and Anandharamakrishnan C 2014 *Innov. Food Sci. Emerg. Technol.* **23**, 156-63
- [7] Lewicki P P, Walczak W and Goss B 1983 *J. Food Eng.* **2**, 309-22
- [8] Lewicki P P 1984 *J. Food Eng.* **3**, 91-115
- [9] Lewicki P P 1985 *J. Food Eng.* **4**, 265-89
- [10] Kumar A, Bhattacharya M, Blaylock J 1990 *J. Food Sci.* **55**, 1403-11
- [11] Sakai N, Tang J W, Liu C M and Watanabe M 2004 *Food Sci. Technol. Res.* **10**, 79-85
- [12] Rao M A and Anantheswaran R C 1988 *Adv. Food Nutr. Res.* **32**, 39-84
- [13] Horn C S, Franke M, Blakemore F B and Stannek W 1997 *Food Bioprod. Process* **75**, 23-33
- [14] Dilay E, Vargas J V C, Souza J A, Ordonez J C, Yang S and Mariano A B 2015 *Int. J. Energy Res.* **39**, 46-74
- [15] Cordioli M, Rinaldi M and Barbanti D 2016 *Int. J. Food Sci. Technol.* **51**, 854-64
- [16] Rinaldi M, Malavasi M, Cordioli M, and Barbanti D 2018 *Food Bioprod. Process.* **108**, 1-11