

THESIS FOR THE DEGREE OF DOCTOR OF PHILOSOPHY

Techniques for Failure Analysis and Maintenance of Offshore Wind Turbines

ALEJANDRO SANCHEZ SANCHEZ



UNIVERSITÀ DEGLI STUDI DI FERRARA
Engineering Department in Ferrara

Ferrara, February 2018

<i>Title:</i>	<i>Techniques for Failure Analysis and Maintenance of Offshore Wind Turbines</i>
Author:	Alejandro Sanchez Sanchez
University:	Ferrara University (UNIFE)
Branch of study:	Reliability and maintenance of offshore wind turbines
Supervisor	Emiliano Mucchi
Number of pages:	189
Number of figures:	77
Number of tables:	44

Keywords: reliability, availability, maintainability, FMECA, failure mode analysis, preventive maintenance, condition based maintenance, damage detection, damage location, offshore wind energy

The work is dedicated to my family and friends for the support

“A man who dares to waste one hour of time has not discovered the value of life”
Charles Darwin

“Nothing in life is to be feared, it is only to be understood.
Now is the time to understand more, so that we may fear less”
Marie Curie

Abstract

This thesis reports investigations regarding RAMS metrics (reliability, availability maintainability and safety) applied to a 10MW offshore wind turbine. Explanations have been done regarding how to perform the core analysis of a Reliability Centered Maintenance (RCM) process for an offshore wind turbine. The aim is to provide an engineering guide which can improve the maintenance of the system, and consequently increases its availability and the production of energy.

The initial investigations have been carried out using a database for an onshore 5 MW wind turbine; the data has then been converted using a proper conversion factor, so that it can be used for a 10 MW offshore turbine case. The reliability and availability of the entire offshore wind turbine have been calculated through Reliability Prediction and a Reliability Block Diagram (RBD). The reliability prediction is developed from the onshore wind turbine reliability data base and applying an accurate conversion factor which assure a perfect offshore environment. Each component is analysed in order to find out the best design through redundancies between them. It helps to develop the reliability block diagram, pointing out the final reliability and availability metrics of the offshore wind turbine.

In addition, a failure mode analysis is done using Failure Mode, Effects and Criticality Analysis (FMECA), in order to identify the most important failure modes in a risk priority order and the effect of each functional failure propagation through the offshore wind turbine. Meanwhile investigations of failure modes, classified by severity, have been conducted in order to identify the riskiest failures for the whole system.

The maintenance part of the RCM analysis has also been studied, to facilitate the creation of an optimum packaging of preventive maintenance tasks, which can help to avoid the functional failures of items throughout the system. Although the main target of the RCM is to reduce the downtime of the wind turbine, a reduction in Life Cycle Costs can be also accomplished through this process.

Moreover, looking to improve the preventive maintenance which is based on scheduled tasks, a Condition Based Maintenance is developed for the riskiest part of the offshore wind turbine. The riskiest part of the offshore wind turbine taking into account the cost are the blades. Hence an impact and damage detection study in composite material is carried out. CBM needs hardware, software, data strategy, sensors, algorithms, maintenance information...etc. in order to be implemented. Through this thesis, a real implementation has been done in a composite material structure, developing the sparse sensor networks, methodologies and software. The CBM will be formed for a Structural Health Monitoring (SHM) system which is able to detect and location a damage in composite material. CBM and PM plans form the RCM and they work together looking for the same purpose, improving reliability and decreasing costs. Then, a statistical novelty damage detection and location approach have been introduced on composite materials applied to offshore wind turbine blades. Impacts through several energies are applied to the structure generating several state conditions. Guided lamb waves (GLW) are used with a pitch-catch active configuration, a PZT sensor acts as actuator and the others PZT sensors pick up the signal. The proposed methodology is tested through a frequency swept starting from 50 kHz to 450 kHz, with a step of 100 kHz. A heterogeneous sensor network is employed, formed by eight PZT sensors. Signals are pre-

processed in order to obtain dominion features that provide information regarding the damage. Damage Indexes are calculated for each sensor path by statistical metrics finding out the variation of each signal due to the impact. Damage Indexes (DIs) are compared from the baseline state condition (healthy condition) against a generated damaged state condition. The indicator of damage is alerted when the Damage Indexes are over the threshold (discordant outlier) marked by the baseline state condition. The comparison is done based on statistical time series signals. The damage location is done through the DIs generating a Damage Index grid map in the structure, finding out where the structural damage is located. The experimental evaluation and assessment have been validated through several aerospace structures.

It will help to develop a Condition Based Maintenance for the offshore wind turbine which will be operational together with the maintenance plan.

A global view of the analysis is shown in the following Figure 1.

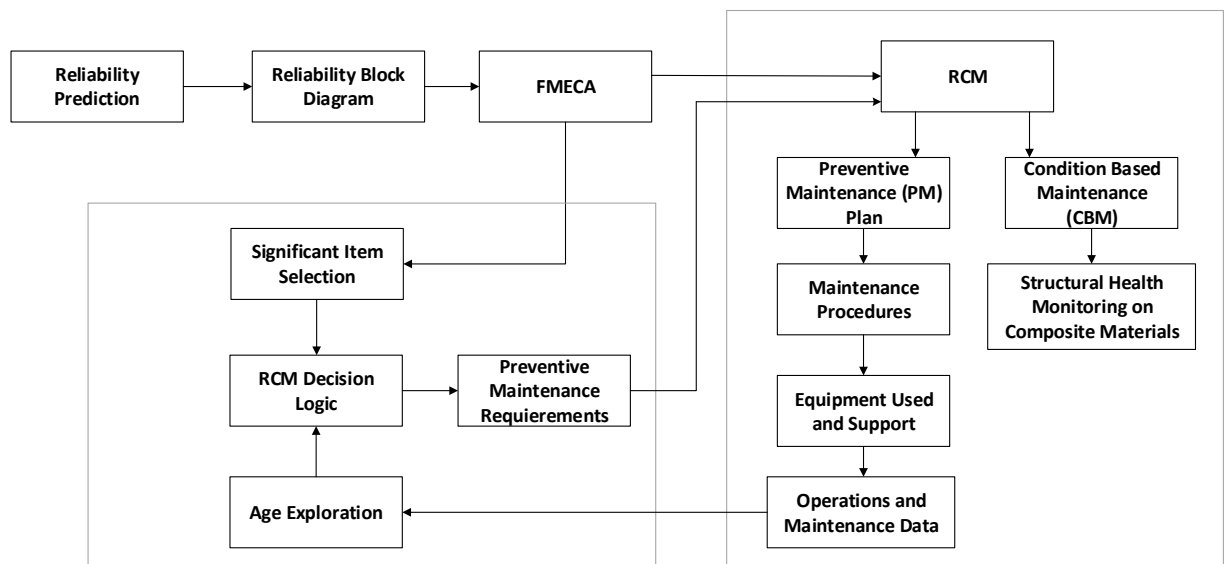

Figure 1. Overview analysis of the thesis

The thesis tries to explain a global analysis never explained together and it could be followed through the blocks in the Figure 1. On the one hand, reliability prediction, reliability block diagram and FMECA is carried out. On the other hand, based on previous studies, two kind of maintenance plans are developed. The maintenance plans follow several steps in order to achieve the best results and looking to keep the offshore wind turbine available the most time possible.

Preface

I graduated in MSc. in Mechanical Engineering by Castilla la Mancha University (UCLM) in 2013. Just this summer I developed an internship in a technical office through the University where I were working for 6 months. I was developing projects, electrical installations, activity studies, etc. Moreover, I developed skills and knowledge writing and leading projects that it has for finality the construction, reform, repair, manufacture installation in the mechanical engineering sector. I was looking new goals and further objectives. Finally, I took the decision to go out to other country to improve languages and improves my skills in other cultures. At the end of this summer, I started to improve my English and German level. In April 2014, I moved to Cambridge (UK) to work in TWI, a multinational company. My department was based on Structural Health Monitoring and I were involved in several European research projects based on condition monitoring. I learnt acoustic emission, PZT sensors, guided waves, dispersion curves, PZT sensor design, wind turbines, vibrations in rotatory machine, etc. I were noticed about a European position called "Marie Curie" and I were very focused to achieved this position because I wanted to carry out a PhD in order to improve my knowledge.

In October 2014, I passed the interviews and I could achieve a Marie Curie position in Rome where I may develop a PhD through the Ferrara University while I were working in Rome for a company called Relex Italia Srl. My role was to improve the reliability of the offshore wind energy and by this way the offshore wind energy will be profitable due to the high O&M costs. The methodologies in order to achieve these improvements are reliability prediction, RBD, FMECA, maintenance plans...etc. This company have been worked for several years in this field and therefore the colleagues would have enough experience to help me in order to achieve the best results. I was working in this company for one year and a half, developing more than the half of my thesis. Several publications have been done during this one year and a half which will be detailed later. This Marie Curie position were a bit special and I had to continue the thesis by myself without any funding and faraway of my supervisor Emiliano Mucchi. After that, a secondment of a month has been done in Ferrara University where knowledge of modal analysis and LMS software have been acquired.

My idea was to finish the thesis with the best quality possible. In September 2016, I moved to Madrid looking new opportunities and finally I started to work in Airbus Defence & Space in the Structural Health Monitoring Department. I was in charge of the technology line and monitoring the Eurofigther aircraft for the Spanish Army. The technology line was focused to develop a system which is able to detect, location, characterize and assessment of a damage in composite material among other things. This system will be implemented in a real aircraft fuselage. Then, starting from curve composite material panel test and ending up cockpit composite material test have been developed. This SHM system will optimize the maintenance scheduled task and therefore improving costs. Hence thanks to Airbus Group and Clean Sky Project (Airbus Group packs all research lines in this project), data from a test can be used for my thesis and achieving an innovative maintenance plan for the offshore wind turbine blades. A journal paper is waiting to be submitted regarding this purposed due to the test is developed through difficult conditions (stringer, compressive and traction loads and fatigue cycles). Through basic statistical approach the damage detection and location is achieved. Moreover, sincerely thanks to Dr. Jaime Garcia Alonso from Airbus Group who is in charge on

the SHM research line and I have improved my knowledge working with him. Thanks to other colleagues who have helped a lot during these 3 years.

CONTENTS

Abstract	5
Preface	8
Statement of originality	24
1 Introduction	25
1.1 Background	25
1.2 Aims and Objectives	26
1.3 Publications	27
2 Literature Review	28
2.1 Review of Reliability Strategies	28
2.2 Review failure mode strategies.....	33
2.3 Review maintenance approaches.....	34
3 Reliability Analysis	39
3.1 Reliability Engineering (RAMS)	39
3.2 Reliability Analysis Procedure	45
3.3 Reliability Model	46
3.4 Reliability Prediction	53
4 Reliability Block Diagram (RBD)	65
4.1 Definition and Assumptions	65
4.2 General Concepts.....	66
4.3 Redundancies.....	67
4.4 Availability of Repairable Systems.....	69
4.5 Reliability Block Diagram Results	70
4.6 Analysis of RBD results	75
5 FMECA approach for an Off-Shore Wind Turbine	80
5.1 FMECA definition.....	80
5.2 Objectives.....	80
5.3 Method.....	80
5.4 Approach	81
5.5 Criticality.....	82
5.6 FMECA process	85
5.7 Limitations	86

5.8	FMECA construction.....	86
5.9	Results.....	88
6	Preventive Maintenance (PM)	103
6.1	Definition.....	103
6.2	Preventive Maintenance Tasks Classification.....	103
6.3	Significant Function Selection.....	104
6.4	Task Evaluation	105
6.5	Task Selection	108
6.6	Packaging.....	111
6.7	Age Exploration (AE)	116
6.8	Repackaging.....	116
6.9	Preventive Maintenance applied to other offshore wind turbine systems	116
7	Condition Based Maintenance (CBM)	127
7.1	Introduction.....	127
7.2	Vibrations on rotatory machinery for offshore wind turbines.....	132
7.3	Damage Detection and Location in Composites Materials based on a Novelty Statistical Approach under Post-Impact.....	136
8	Supportability Software.....	155
8.1	Reliability Analysis	157
8.2	Conversion factor from onshore into offshore.....	162
8.3	FMECA Analysis.....	166
8.4	Life Cycle Analysis	166
8.5	Maintenance Plans.....	167
9	Model Validation	169
9.1	Software results against reliability results	169
9.2	10 MW Offshore Wind Turbine against other published wind turbine results	169
10	Conclusions	176
11	Bibliography	179

LIST OF FIGURES

Figure 1.	Overview analysis of the thesis.....	6
Figure 2.	Comparison between onshore data-bases.....	32
Figure 3.	Time to failure distribution.....	40
Figure 4.	Bathtub Curve: typical shape of the failure rate on items.....	42
Figure 5.	Reliability Function.....	44
Figure 6.	Reliability Analysis Procedure.....	45
Figure 7.	Whole hierarchy offshore wind turbine.....	47
Figure 8.	Wind Turbine with DFIG (doubly fed induction generator) [123] ..	48
Figure 9.	Hydraulic pitch system.....	48
Figure 10.	Yaw system.....	49
Figure 11.	Wind turbine systems. [Wind Energy Technologies Office].....	52
Figure 12.	Percentage of component nominal rating plotted against stress factor K2. Graph constructed based on the data presented in Table 6.....	58
Figure 13.	Results Reliability Prediction on sub-systems.....	60
Figure 14.	Results Reliability Prediction on Sub-Assemblies.....	61
Figure 15.	Reliability Prediction Results Part 1.....	62
Figure 16.	Reliability Prediction Results Part 2.....	63
Figure 17.	Reliability Prediction Results Part 3.....	64
Figure 18.	Pitch system RBD.....	65
Figure 19.	Development of a RBD within a system.....	66
Figure 20.	Main RBD of the Offshore Wind Turbine.....	66
Figure 21.	Items in series redundancy.....	68
Figure 22.	Items in parallel, load sharing or standby redundancy.....	69
Figure 23.	Non-reparable system and b) Repairable system.....	70
Figure 24.	Results RBD on sub-systems.....	70
Figure 25.	Reliability through time in a year operation.....	71
Figure 26.	Comparative results between RBD and Reliability Prediction.....	72
Figure 27.	Comparative results between RBD and Reliability Prediction.....	72
Figure 28.	Results RBD on Assemblies.....	73
Figure 29.	Distribution of failures per year/turbine.....	74
Figure 30.	Whole Hierarchy Offshore DTU 10MW Wind Turbine.....	77

Figure 31. RBD Offshore Wind Turbine	78
Figure 32. RBD Offshore Wind Turbine	79
Figure 33. Example of the hierarchy structure used to perform the FMECA	81
Figure 34. Risk Matrix	84
Figure 35. OWT Structure	88
Figure 36. Item Criticality number (Cr) distribution	89
Figure 37. Severity Distribution Pie Diagram	90
Figure 38. Top 10 Failure Mode Causes	91
Figure 39. Top 10 Mode Criticalities	92
Figure 40. Top 10 RPN	94
Figure 41. Significant Function Selection Logic Diagram	105
Figure 42. Decision Logic	106
Figure 43. Example of Decision Logic for the MV Switchgear and Transformer	107
Figure 44. Estimate probability of failure	128
Figure 45. Bathub curve	128
Figure 46. Probability of failures	129
Figure 47. Example of a time signal converted to frequency domain	132
Figure 48. Peaks and harmonics of frequency domain signal	134
Figure 49. Gear mesh spectrum	135
Figure 50. Composite material panel FLHYB06	138
Figure 51. PZT sensors and impacts in the composite panel	141
Figure 52. Flowchart data acquisition system	142
Figure 53. Reference and damage state condition through active approach	143
Figure 54. Excitation signal	143
Figure 55. Crosstalk Example	144
Figure 56. Input Signal from Actuator from piezoelectric 1 to piezoelectric 2	145
Figure 57. Example of Reference and Damaged Signals	146
Figure 58. <i>DIUndamaged – Undamaged case</i>	146
Figure 59. <i>DIDamaged – Damaged case</i>	147
Figure 60. <i>DIUndamaged – Damaged case</i>	147
Figure 61. Damage Index ideal case	148

Figure 62. Distribution based on DI.....	149
Figure 63. DI applied to sensor paths	151
Figure 64. DI applied to a sensor network.....	151
Figure 65. DI map through the example structure	152
Figure 66. Damage Location through all frequencies.....	152
Figure 67. Damage Point	153
Figure 68. Damage Location Point.....	154
Figure 69. Grafical user interface of the Matlab Software	156
Figure 70. Conversion factor function, K2 againts PCNR	166
Figure 71. Damage Location I4 Impact	168
Figure 72. Reliability Results from literatura review	170
Figure 73. Reliability Results from literatura review	170
Figure 74. Reliability Results from literatura review	171
Figure 75. Reliability Results from literatura review	171
Figure 76. Reliability Results from literatura review	172
Figure 77. Reliability Results literature review	172

LIST OF TABLES

Table 1.	Data sources for prediction analysis	30
Table 2.	Offshore Wind Turbine Description	51
Table 3.	Description Onshore Wind Turbines Reliawind Project.....	55
Table 4.	Environmental stress factor.....	56
Table 5.	Power rating stress factor for mechanical components.....	57
Table 6.	Results Reliability Prediction.....	59
Table 7.	Results Reliability Prediction on Assemblies.....	59
Table 8.	Results Reliability Block Diagram	71
Table 9.	FMECA MIL-STD-1629 tasks.....	80
Table 10.	Criticality numbers description from "MIL-HDBK-1629"	82
Table 11.	β classification from MIL-HDBK-1629	82
Table 12.	Severity classification.....	84
Table 13.	Frequency classification.....	85
Table 14.	Worksheet information header	86
Table 15.	General description of the worksheet columns	87
Table 16.	Detection classification.....	93
Table 17.	General Assumptions.....	96
Table 18.	Vessel Features	96
Table 19.	Cost Analysis on several assemblies of the OWT.....	98
Table 20.	Classification of most expensive failure modes.....	99
Table 21.	FMECA of the Offshore Wind Turbine. Part 1	100
Table 22.	FMECA of the Offshore Wind Turbine. Part 2	101
Table 23.	FMECA of the Offshore Wind Turbine. Par	102
Table 24.	General assumptions	109
Table 25.	Crew Transfer Vessel features.....	109
Table 26.	Maintenance task assignation	110
Table 27.	Maintenance task classification by sub-systems.....	112
Table 28.	Maintenance task descriptions.....	113
Table 29.	Packaged tasks by intervals for MVS and GE.....	114
Table 30.	Packaged tasks for the first 6 years	114
Table 31.	Working hours for the first 6 years	115

Table 32.	Packaging overview for year 0	115
Table 33.	Preventive Maintenance. Table1. Part 1	117
Table 34.	Preventive Maintenance. Table 2. Part 1	118
Table 35.	Preventive Maintenance. Maintenance Tasks. Part 1	120
Table 36.	Preventive Maintenance. Details for each Maintenance Tasks. Part1	122
Table 37.	Preventive Maintenance. Maintenance tasks. Part 2	124
Table 38.	Preventive Maintenance. Details for each maintenance tasks. Part 2.....	126
Table 39.	Low energy impacts and fatigue task's sequence	139
Table 40.	Reference and damaged cases state conditions	140
Table 41.	Sensors activated for each impact	140
Table 42.	Summary tests of damage detection.....	150
Table 43.	Impact position	153
Table 44.	Failure rate literature review.....	175

Nomenclature

$\bar{v}(t)$	Right continuous decreasing step function
$E(\tau)$	True value of the mean failure-free operating time
$R(t)$	Reliability function
$\lambda(t)$	Failure rate
$E[\tau]$	Mean time to Failure
$f(t)$	Probability of failure
$K_{1 \text{ offshore}}$	Environmental Stress factor
$K_{2 \text{ offshore}}$	Power rating stress fact
μ	Mean repair rate
C_r	Criticality number for the item
C_m	Criticality number for a failure mode under a particular severity classification
α	Failure mode ratio
λ_p	Part failure rate
β	Conditional probability of mission loss given that the failure mode has occurred
t	Mission time.
n	The failure modes in the items that fall under a particular severity classification
j	Last failure mode in the item under the severity classification.
F	Frequency

Abbreviations

A	Availability
CA	Criticality Analysis
Cm	Mode criticality number
CM	Corrective Maintenance
Cr	Item criticality number
FR	Failure Rate
FBD	Functional Block Diagram
FIT	Failures In Time
FMEA	Failure Mode and Effects Analysis
FMECA	Failure Mode Effects and Critical Analysis
FRACAS	Failure Reporting Analysis and Corrective Action System
FT	Fault Tree
FTA	Fault Tree Analysis
LCC	Life Cycle Cost
LCN	Life Control Number
LRU	Line Replaceable Unit
LSA	Logistic Support Analysis
LSAR	Logistic Support Analysis Record
M	Maintainability
M&O	Maintenance and Operations
MDT	Mean Down Time
MP	Maintainability Program
MPA	Maintainability Plan Analysis
MTBF	Mean Time Between Failure
MTBM	Mean Time Between Maintenance
MTTR	Mean Time to Repair
MTTPM	Mean Time to Preventive Maintenance
OWT	Offshore Wind Turbine
R	Reliability
RAM	Reliability, Availability, Maintainability
RCFA	Root-Cause Failure Analysis
RCM	Reliability Centred Maintenance

RTF	Run to Failure
TQM	Total Quality Management
WTG	Wind Turbine Generator

Definitions

These definitions help to understand the whole thesis. [1]

“Availability”	Probability that an item will perform its required function under given conditions at a stated instant of time. [1]
Catastrophic Failure	A failure Mode which causes Death, system loss or severe environmental damage. [1]
CM “Corrective Maintenance	Maintenance carried out after fault recognition, intended to put an item back into a state in which it can again perform its required function. [1]
Critical Failure	A failure involving a loss of function or secondary damage that could have a direct adverse effect on operating safety, on mission, or have significant economic impact. [1]
Critical Failure Mode	A failure mode that has significant mission, safety or maintenance effects that warrant the selection of maintenance tasks to prevent the critical failure mode from occurring. [1]
Dominant Failure Modes	The failure modes that are most likely to occur during the lifetime of the item, component, or equipment. [1]
Effective PM Task	The characteristic of a preventive maintenance task when it is capable of improving equipment reliability to a given level under specific constraints (i.e., cost-effective). [1]
Failure Mode and Effects Analysis (FMEA)	Analysis used to determine what parts fail, why they usually fail, and what effect their failure has on the system (End Item). An element of Reliability Centered Maintenance (RCM). [1]
FR "Failure Rate" (fpmh)	This term defines the number of failures for one million of Hours. [1]
Item Criticality (Cr)	The item criticality is a calculated field used in the FMECA worksheets. There are up to 4 different item criticalities corresponding to up to 4 severity levels (see Severity Classification). The item criticalities are the sum of the mode criticalities for all failure modes within a particular severity level. [1]
Maintainability	A design objective which provides for easy, accurate, safe, and economical performance of maintenance functions. [1]
Mode Criticality (Cm)	A factor used in a criticality matrix representing the degree of criticality of the failure mode under a particular severity classification. [1]

MTBF "Mean time between failure"	This term defines the mean time between failures. Expressed in Hours of operations for a specific module population. It does NOT mean that a module will operate for that many Hours before failure. [1]
MTTF "Mean Time to Failure"	This value is very similar to MTBF and is used when evaluating non-repairable systems. MTBF assumes that a device is to experience multiple failures in a lifetime, and after each failure a repair occurs. For non-repairable systems, there is no repair. Therefore, in the lifetime of a non-repairable device, the device fails once and MTTF represents the average time until this failure occurs [1]
MTTR "Mean time to repair"	This term defines the expected mean value of an item's repair time [1]
Performance Standards	Those standards which an item is required to meet in order to maintain its required function. The performance standard defines functional item failure. [1]
Preventive Maintenance (PM)	The planned, scheduled periodic inspection, adjustment, cleaning, lubrication, parts replacement, and minor repair of equipment/ systems for which a specific operator is not assigned. Preventive Maintenance consists of many checkpoint activities on items that, if disabled, would interfere with essential system operation, or property, or involve high cost or long lead time for replacement. Also called «time-based maintenance» or «interval-based maintenance.» Depending on the intervals set, PM can result in a significant increase in inspections and routine maintenance; however, it should also reduce the frequency and seriousness of machine failures for components with defined, age-related wear patterns. [1]
Proactive Maintenance	Application of predictive maintenance technologies toward extending machinery life. It seeks to eliminate the need for maintenance through better design, better installation, precision balance and alignment, and root-cause failure analysis. [1]
Reactive Maintenance	Often called «breakdown maintenance,» «reactive maintenance,» or «run to failure (RTF).». Maintenance or equipment repairs are performed only when the deterioration in a machine's condition causes a functional failure. A high percentage of unplanned maintenance work, high replacement part inventories, and the inefficient use of maintenance personnel typify this strategy. [1]
Reliability	The ability of an item to perform a required function under stated conditions for a given time interval

(usually expressed as a probability). Reliability is expressed as a probability value (a value between 0 and 1). For constant failure rate systems, the equation for the calculation of reliability is: $R = e^{-\lambda t}$ where t is the mission time, and λ is the failure rate. [1]

Reliability Block Diagram

Block Diagram showing how failures of elements, represented by the blocks, result in the failure of an item or system. [1]

Reliability Centered Maintenance (RCM)

A maintenance strategy that logically incorporates into a maintenance program the proper mix of reactive, preventive, predictive, and proactive maintenance practices. Rather than being used independently, the respective strengths of these four maintenance practices are combined to maximize facility and equipment operability and efficiency while minimizing required maintenance time, materials, and consequently, costs. For example, a small pump might be run to failure, a gasoline engine might be placed on a 1,000-hour PM program, and a critical turbine might be monitored with on-line diagnostic sensors. This strategy often includes performing a so called «Failure Mode and Effects and Criticality Analysis (FMECA),» to identify those processes or systems that statistically exhibit the greatest chance of critical and catastrophic failures. [1]

Repair

That facility work required to restore a facility or component, including collateral equipment, to a condition substantially equivalent to its originally intended and designed capacity, efficiency, or capability. It includes the substantially equivalent replacements of utility systems and collateral equipment. [1]

Statement of originality

Literature review has been done in areas such as: offshore wind energy, reliability, availability, failure mode, maintenance, cost wind energy and structural health monitoring. The state-of-the-art and limitations have been understood, applying improvements in fields as reliability, failure mode analysis and maintenance plans.

Nowadays no reliability offshore data-base is available. A data-base of several onshore wind turbine are available to carry out the analysis coming from manufacturers. This data base is bigger than published data-base, reflections good conclusions.

Investigations of redundancies between the offshore wind turbine components have been done, looking to improve the design and therefore the reliability of the wind turbine. Moreover, the development of each components has been analysed based on its failure modes.

The development of a preventive maintenance plan based on reliability and failure mode analysis. These analyses point out the riskiest failure modes and the frequency of failure and therefore it helps to develop the preventive maintenance. Moreover, the development of a structural health monitoring system which mainly will form the Condition Based Maintenance (CBM). The system is able to detect and located an event and if the structure is damaged, showing the place where has been the damage. The SHM system is based on a novelty damage detection and location approach. This Condition Based Maintenance is implemented on blades, the riskiest and expensive part of the offshore wind turbine.

The whole study is assembled in a Matlab Software. This software has been designed under several purposes. It starts with the reliability prediction analysis under specified inputs. Failure modes are introduced in the software in order to form a data-base which could be used in other fields. The preventive maintenance plan is optimized, looking the best relation between cost and frequency time through an iteration model. The condition monitoring methodology for blades is shown through this software. The software can be used to validate the thesis results. All is packed in the software which can be used with a graphical user interface.

1 Introduction

1.1 Background

In the last decade, the installed capacity of offshore wind turbines is higher than other renewable energy sources. Offshore wind farm developments have a short history of less than 30 years. On this time, offshore wind turbines have been getting bigger and higher rated power. Therefore, wind power is achieving 10MW from 450kW when the first offshore wind turbine was built on the coast of Denmark in 1991. During the first six months of 2015, 15 offshore wind farms have been installed with a combined capacity of 2,342.9 MW [2]. Hence, the energy increase induces new researches for improving efficiency in terms of performances and costs.

One of the targets of the European Commission is to increase the production of the renewable energy generated by the offshore wind turbine to 40GW by 2020 and 65GW by 2030, allowing wind energy to make up more than 25% of electricity generation in Europe. The relevance of this topic has been well understood by the European Commission, which had promoted in 2008 a research projects named Reliawind (Project ID:212966) in [3], [4], [5], [6] and [7], based on a reliability study for an onshore wind turbine. In 2014, when the Mare-Wint (new MAterials and REliability in offshore WIND Turbines technology) Project (Project ID: 309395) has been approved focus on offshore wind energy, a step forward has been moved in order to achieve the forecast. A wind power system located in offshore shows higher failure rate, lower reliability and availability and higher operation and maintenance (O&M) costs due to the high complexity of the operation [7-14]. The Mare-Wint Project has started in October 2012 inside FP7-PEOPLE-2012-ITN Marie-Curie Action: "Initial Training Networks". The PhD has been sustained by this European Project for one year and a half starting the October 2014. Moreover, the PhD candidate has been working at the same time developing the PhD in a company called Relex Italia Srl located in Rome. This company as the Ferrara University have been two partners of the Mare-Wint Project. Moreover, the PhD candidate is working in Airbus Group located in Madrid since September 2016. Thanks to Airbus Group and Clean Sky Programme, data from a test has been used to improve the maintenance plan as will be explained.

According to the considerations above, reliability and availability evaluations allow to optimize the design and the life cycle management from a cost/efficiency point of view. In addition, a proper maintenance plan is indispensable to predict the energy loss, minimizing failures in order to improve reliability and making offshore wind energy profitable.

In order to get this aim, along this thesis is explained the reliability and the FMECA that has been done for the 10MW offshore wind turbine. The reliability study is carried out with a very important wind turbine data base of the sector. Relex Italia Srl. has available this large database (over a thousand components). Published reliability offshore databases are not available. A literature review about free database has been done and the best option has been selected. Moreover, a conversion factor is applied to this database which will be explained. After that, the FMECA is used to identify reduce system failures and nowadays put into practice for OWT. Based on that studies, two kind of maintenance plans are developed looking to increase the availability of the offshore wind turbine and therefore making more profitable the offshore wind energy and competitive against other energies.

1.2 Aims and Objectives

- This thesis looks to improve the reliability of the offshore wind turbines through several ways and therefore the profitability of the offshore wind energy. Offshore wind turbine presents high maintenance costs due to the environment where is installed. In order to reduce the maintenance, the reliability has to be higher, reducing to the minimum the maintenance of the offshore wind turbine. Two types of maintenance are proposed. The preventive maintenance is based on scheduled maintenance task which are under a scheduled time based on analysis such as: Reliability Prediction, Reliability Block Diagram (RBD), FMECA, etc. The Condition Based Maintenance plan is the best maintenance for the riskiest and most expensive part of the offshore turbine, the blades. Condition Based Maintenance sometimes requires expensive equipment and therefore has high costs at the beginning and it has to be analysed if the investment is profitable. Summarising, improvements for the offshore wind turbine are coming from:
 - Advices in the design with the reliability prediction and RBD.
 - FMECA points out all possible failure modes of every components and therefore it can be taken into account for the further designs and maintenance purpose.
 - Maintenance plans for the offshore wind turbine
- All wind turbine manufacture companies have excellent data base regarding failure rate of components and failure modes along years, etc. These data base cannot be found published and therefore it is very difficult to have a good data base regarding each component of a wind turbine. There are several published data-bases but don't provide too much information due to only point out the failure rate of wind turbine assemblies. Then the data base must come from other reliable way. Other way is from the experience of the company which the PhD candidate had been working for a year and a half. More than one thousand of components are available in this data base. This data base come from "Reliawid Project" which had been formed by important manufacture companies in the field. This confidential information is difficult to achieve through published data bases. After that, results and conclusions from this data-base are used in order to develop the maintenance plans.
- Maintenance techniques are changing and evolving quickly. Condition Based Maintenance is getting more important in order to improve the maintenance tasks and reducing the cost. The costs are reduced by energy losses and task optimization. The CBM develops the maintenance tasks at the right time when the wind turbine needs. It is a key point of the CBM. It is based on a SHM system which is based on novelty methodology. The system is developed in order to detect and location of damage in composite material. Damage detection in metallic structures are very studied and good methodologies have come out. For composite material, it is not so clear and there are doubts due to the behaviour of waves may change in composite material. Damage detection and location methodologies are shown for a composite material panel which has been subjected to compression and traction loads, fatigue cycles and impacts of several energies. Moreover, the composite panel has stringers and omegas which can aggravate the waves

behaviour. This test has been developed by Airbus Group in the headquarters of Getafe (Spain) inside Clean Sky Programme. It will contribute to the creation of a SHM system. This methodology must be assembled into a system which could be installed in the offshore wind turbine. The system would be formed by two approaches. One of them, the passive system detects if an event has appeared. In this thesis, the passive system is neglected. The other one, the active system which is exposed and the damage detection and location of the previous event is indicated. It will mainly compose the Condition Based Maintenance (CBM) proposed together with the Preventive Maintenance developed.

- The Preventive Maintenance will be focused for components which has scheduled time based on failure rate and failure modes. It has been done under a deep study of failure rate of all components and a failure modes, effects and criticality analysis. It finds out conclusions which are used to develop the Preventive Maintenance plan. The FMECA analysis is composed of almost six hundred pages and therefore it could be used as a data-base for the components applied to any fields.
- The previous analysis are validated through a Matlab software. This software is based on the reliability prediction, FMECA, Preventive Maintenance and Condition Based Maintenance. Through a graphical interface designed, all steps can be followed. The software develops functions such as:
 - Reliability Prediction
 - FMECA
 - Optimization of the maintenance
 - Damage detection and location for the Condition Monitoring Maintenance.

1.3 Publications

The thesis has been explained through several papers and a chapter book. The following publications have been submitted during the research work:

1. Alejandro Sanchez Sanchez, Itamar Esdras Martinez Garcia, Emiliano Mucchi. «Reliability Prediction and Reliability Block Diagram of Offshore Wind Turbine.» *EWEA 2015 Paris Wind Energy Event*. Paris, 2015 [8].
2. Alejandro Sanchez Sanchez, Itamar Esdras Martinez Garcia, Emiliano Mucchi. «Reliability and Failure Mode Analysis of an Offshore Wind Turbine.» *Quinta Giornata de Studio Ettore Funaioli*. Bologna, 2015 [9].
3. Alejandro Sanchez Sanchez, Itamar Esdras Martinez Garcia, Stefano Barbati. «Reliability and Preventive Maintenance.» *MARE-WINT NewMaterials and Reliability in Offshore Wind Turbine Technology*. Springer, 2016. 233-272 [10].
4. Alejandro Sanchez, Patricia Fernandez, Angel Lozano, Jaime Garcia, Manuel Iglesias. «Damage detection and location in composite material structures under post-impacts. » Pending to submit.

2 Literature Review

Offshore wind energy has a short history of less than 30 years. The first issue arises when it is taken into account the environment where the wind turbines are installed. Hence one of the objectives of the wind energy is to reduce the cost of the energy. It has reached if the reliability of the whole offshore wind turbine. Moreover operations & maintenance strategies (O&M) are important due to the accessibility of the wind turbines. It will have a straight impact to the availability. Higher availability entails decrease the cost and increase the energy produced. It will make the offshore wind energy than productivity than other energies.

The construction of an offshore wind turbine involves fields as mechanical, materials, monitoring of the structure, fluid mechanics, electric, hydraulic, aerodynamic...etc. The perfect works of every components achieve better energy output and minor failure rate.

Along the time, the offshore wind energy is getting more reliable and it is due to investigations how has been done in this thesis. Offshore wind energy has more impact in countries as Denmark, England, Netherlands, Germany...etc, where are being installed a lot of wind farms. The quality of every component is higher and therefore the failure rate is reduced. Moreover, the maintenance techniques have been perfected along the time.

The selected reference wind turbine is proposed from DTU University. This University is a partner in the Mare-Wint Project and the description of the 10MW offshore wind turbine can be seen in [11].

The literature review has been conducted through three aims. Firstly, the reliability field is analysed, taking a view through the methodologies and the data-base which can be used for this purpose. After that, maintenance approaches will be analysed along the time.

2.1 Review of Reliability Strategies

The first methodology used is the reliability prediction. Component failure rates has to be needed in order to develop it. Failure rate data could come from different ways and the best one has to be analysed because it will set further studies and then a good estimation of the probability of failure has to be done. Component data about the failure rate or MTBF, MTTR, description...etc. has to be known for this aim. There are a lot of sources from the data-base could come such as:

- Failure Rate Data Sources:
 - Component failure rates derived from service experience (Reliawind Project)
 - Supplier data
 - OREDA Offshore Reliability Data Handbook [12].
 - RIAC-HDBK-217Plus
 - MIL-HDBK-217F "Reliability Prediction of Electronic Equipment".
 - MIL-HDBK-338B.
 - SR-332 Issue 2, Reliability Prediction Procedure for Electronic Equipment.
 - IEC 62380, Ed.1 RDF 2003: Reliability Data Handbook - A universal model for reliability prediction of Electronics components, PCBs and equipment.

- NSWC-07, Handbook of Reliability Prediction Procedures for Mechanical Equipment;
- NPRD-95, "Non-electronic Parts Reliability Data".
- RDF 2000/IEC.
- HRD5
- Siemens SN29500
- FIDES
- 217Plus
- Telcordia
- PRISM
- Mechanical (NSWC98/LE1)
- The onshore wind turbine failure rate data-base:
 - Windstats.
 - NRD (National Reliability Data base)
 - WMEP
 - LWK
 - Felanalys
 - DV

Then a deep evaluation has to be done in order to find out the success reliability data-base for the offshore wind turbine. The onshore wind turbine failure rate data-base must be better because they treat on specific components allocated in wind turbines and it would achieve better results. There is not published offshore data-base. All published onshore wind turbine data-base are analysed. These data-base don't show too much information regarding the components and instead of that it points out failure rate at sub-system levels. For example, results are shown at Drive Train Module, Blades, Rotor Module...etc and therefore this way doesn't provide enough information. Comparison between data-bases are made in following sections.

There are a lot of journal papers based on these published data-base that doesn't go deeply in the analysis and had been shown results at system or subsystems level. Reliawind Project has created reliability results at system and sub-system level. This project was funded with several companies and universities from the field. **Tavner, Spinato, Van Bussel** and them colleagues have known how to take advantage of the results and they have published several documents focused on the reliability of onshore wind turbines [13], [14], [15], [16], [17], [18], [19], [20], [21]. This document starts with a great introduction and explanations regarding reliability, availability, etc. Results based on other published data-base are shown and getting very useful conclusions of these results. Each paper is focused in a specified onshore data-base. The published onshore reliability data-base are cited before. These conclusions are based on poor, scarce and with little information database and therefore good conclusions can not be achieved. Moreover, criticism and doubts come due to these onshore data-bases show very different results between them and pointing out different failure rates depending on the energy generated and environment. It can be seen in the following Figure 2.

Kaidis has developed a whole reliability prediction study of the wind turbines. He starts with a literature review of reliability data-base and develop a prediction model based on these data-base [22]. **Hameed** has done a literature review and the need for a reliability data-base proposing a database that comes from various paths [23]. **Buckley** develops a failure rate prediction of the wind farm component but it is based on a published reliability data-base [24].

An important metric that must be taken into account is the availability of wind turbines. It is analysed through several papers such as: [25], [26], [27] and [28]. These papers explain the availability concept and to study O&M costs for each wind turbine component based on other projects. It is analysed superficially and an own analysis is not carried out. In this thesis, O&M costs are analysed deeply for offshore environment taking into account separately each component. Availability results are studied through the RBD in the section 4.

An interesting reliability study has been done based on wind turbine load. A fatigue analysis is developed based on these load along the wind turbine and therefore reliability analysis through the wind turbine fatigue is done. These concepts have been taking into account and used for the reliability and failure mode analysis [29].

Tavner analyses the offshore wind turbine situation, defining the important concepts which can affect to the performance of a wind turbine [27]. Results such as air velocity, sensitivity analysis, capacity factor...etc are shown in this paper. Moreover, regarding this aim, the report [30] go deeply to the design conditions which can improve the wind turbine performance.

The reliability standards for electronic equipment mainly have been checked taking a comparison against our data-base [31] and [32]. They are a good estimation if any data from service experience is achieved. Moreover, the published reliability data-bases can be found on internet. At the starting, a look has been taken to the Oreda Data-Base [33].

Relex Italia Srl. submitted several documents for the Reliawind Project which have been used as support for the analysis and can be seen in [3], [4], [5], [6], [34], [35] and [7].

The onshore data sources of Table 1 were considered, which are from three different European countries: Denmark, Germany and Sweden.

From	Databases
<i>Germany</i>	<i>WindStats, WMEP, LWK</i>
<i>Denmark</i>	<i>WindStats</i>
<i>Sweden</i>	<i>Felanalysis, DV</i>
<i>European Commission</i>	<i>Reliawind Project</i>
<i>Handbooks</i>	<i>MIL-HDBK, OREDA, Siemens, NSWC, IEC, NPRD, Fides, EPRD, etc</i>

Table 1. *Data sources for prediction analysis*

It can be compared that similar failure rate are recorded for each data source. There are only two data-bases, WMEP range power and WMEP Germany, that have higher predicted failure rate.

Every data-bases that have been showed, Windstats, WMEP, LWK and Swedish Wind, are onshore data bases but the great problems are:

- They have been created 12 years ago.

- They are very old and the onshore wind turbines have very low nominal power.
- These databases only give information regarding general assemblies and doesn't show information regarding the system hierarchy and parts for each assembly then there isn't enough information.

The failure rate per year of wind turbines based on different data-base are plotted in the Figure 2. For each data-base, failure rate per year is very different between each data-base. It generates doubt and confusion due to in each data base indicates a different failure rate. It can be due the different wind turbine output energy and environment but these data-base are made by onshore wind turbines with similar energy output. Moreover, the analysed countries are close between them and therefore the environment conditions must be similar. It could also be due to the quality of the selected components for the wind turbine but anyway failure rate is doubtful. The energy output of the wind turbine changes but the differences between each data base are high. Doubts and criticism may come out if these data-base are selected.

Evaluating other data sources, information from supplier data cannot be achieved because this information is usually restricted.

Failure rate data sources are a good trigger if any information is known as the latest option.

Hence the best available data-base comes from the service experience. Restricted information regarding two onshore wind turbines have been available through the Reliawind Project. This project has been funded in 2008 for three years and it gathered together field companies with the same purpose each one being expertise in a matter. Relex Italia was gathering the reliability model for these two onshore wind turbines. These wind turbines come from important manufacturer companies in the wind energy, presenting several designs. Several reliability models were created of more than one thousand components each one. It converts the service experience the best available data-base.

When the reliability information is gathered, the reliability analysis could be started. Through the selected data-base, failure rate along the life is not available. It means that the reliability data cannot be studied with a statistical curve. The most famous is the Weibull Curve which provide a good estimation along the life of the component. There are studies based on reliability life data but are not reliable due to are based on small amount of data. Instead of that, failure rate under a fixed time has been gathered from manufacturers of wind turbines. There are a lot of documentation regarding this issue [36], [37], [38], [39], [40] [41], [42] [1], [43], [44] [45], [46], [47], [48], [49], [50], [51]. The reliability life of the offshore wind turbine is neglected in this thesis due to the gap of information as is shown in the previous bibliography. Through these papers and handbooks explain the reliability theory through examples applied to several fields but these bibliographies are mainly theoretical. RAMS metrics, failure rate, MTBF, RBD, etc. have been studied through these bibliographies. Reliability prediction and reliability block diagram are based upon known methodologies. The innovation comes from the data-base used and this study has been developed with a complete data-base and with a quality failure rate coming from wind turbine manufactures.

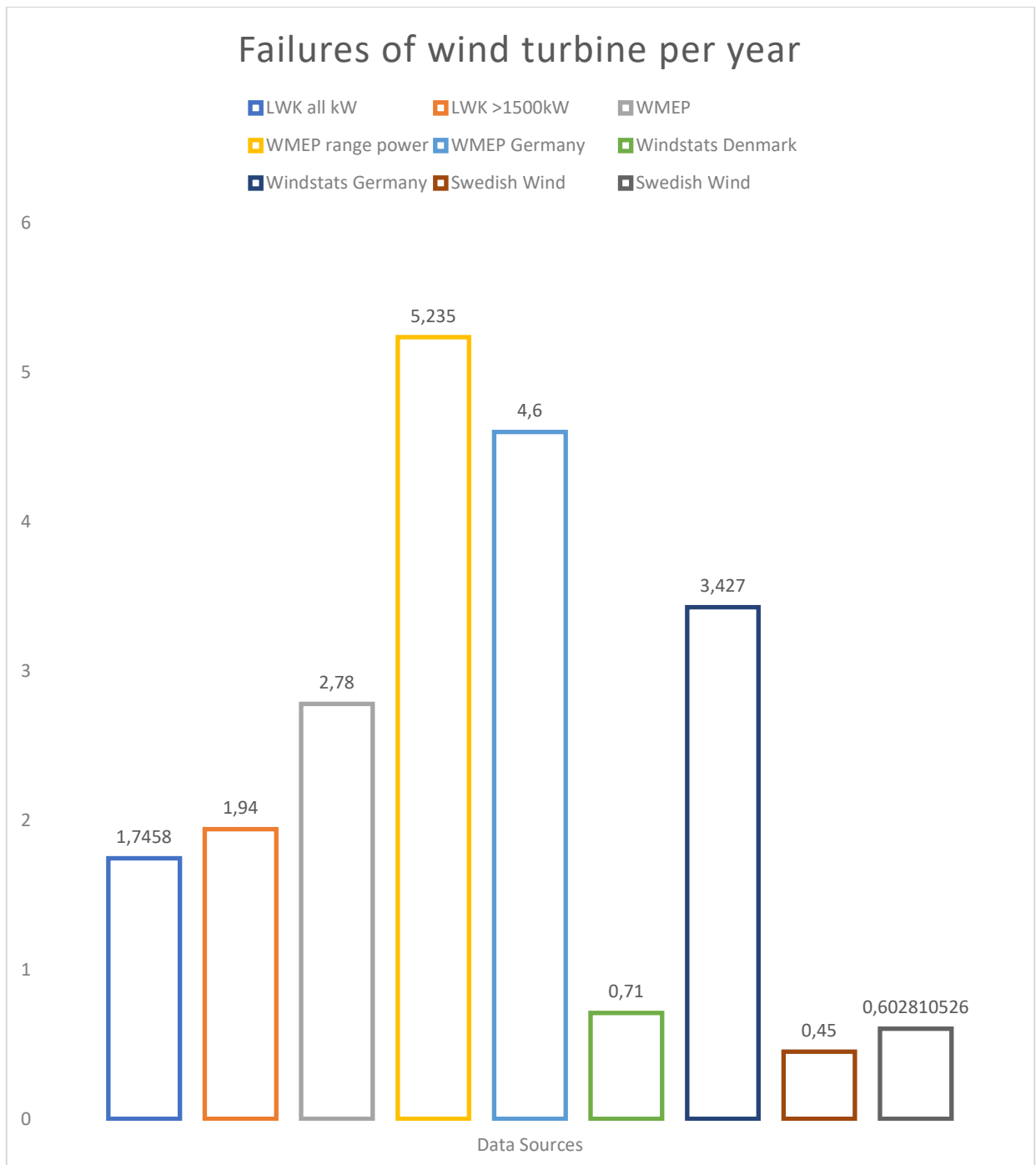

Figure 2. Comparison between onshore data-bases

Along the time, reliability and O&M have been getting more important when offshore wind turbines appear. Offshore wind energy won't be competitive until the reliability is higher. Then investments are applied to this field in order to improve. Several whole studies are available [52], [53] and [54]. **Karyotakis** looked to reduce the CO₂ emissions from wind turbines. A software was developed which could select between two types of preventive maintenance plans and therefore it has less capabilities. **Onwukwe** developed a theoretical thesis which helps to get concepts. **Takoudis** is focused on reliability and redundancies of the system.

2.2 Review failure mode strategies

Along the time, economical aspects on offshore wind turbines are getting more important, especially nowadays with a continuous wind turbine's enlargement and for this reason reliability improvements are needed. FMECA is a reliability analysis method which identifies all possible failure modes and to prevent functional failures before they occur. The classic methodology for FMECA has been used. However, the riskiest parts of the offshore wind turbine have been found out.

The main target of this section is to discover the weakest parts of the system, starting from understanding their failure modes and how are propagating through the wind turbine.

FMECA is a great help for technicians who are carrying out maintenance and need to know technical information. The preventive maintenance needs this reliability analysis because failure modes are in a risk priority order. FMECA is a process which could be updated when more knowledge or experience about the system are known.

Effects of multiple item failures on wind turbine functions and redundant items are not covered for this analysis. However, some other techniques, such as Fault Tree Analysis (FTA) and Markov analysis can be used when multiple item failures occur.

One of the outputs from FMECA is the criticality study (RPN) which the riskiest failure modes are calculated when severity, occurrence and detection are multiplied. There are several authors that have been written about the criticism or doubts that could have RPN analysis [55], [56], [57], [58].

Over time RPN weaknesses are being reported for several authors. For example,

- In 1998 **Garrick** considered other failures considerations as quality of products, environmental safety and production losses [59].
- In 1995, **De Vita** introduced a whole economic analysis on all failures [60].
- In 1990, **Montague** try accurately the economic importance of each failure [61].
- **Bandelloni** in 1999 reported economic aspects in FMECA in order to define better maintenance strategies [62].
- 1993 **Gilchrist** discussed the lack of cost per fault in FMECA [63]. Gilchrist proposed different graduation on RPN parameters as **Kmenta** suggested who gave less importance to detection because it is more important whether the failure occurs than the probability of detect a failure.
- 1996 **Raouf** and **Ben-Daya** reaffirm problems that Gilchrist had said. They developed a study without taking into consideration severity aspect. Considering this study, Gilchrist pointed out several problems as the linear relation in the parameter's score [64].
- **Montgomery** had reported very good sensations about FMECA and it could have great importance [65].
- **Huibin** and **Jun** et. Al announced that FMECA results are questionable and sometimes doubtful [66].

- **Rhee** and **Ishii** said that the fact that measuring severity and detection are difficult and subjective as several authors had been saying. They proposed a new method which costs were taken into consideration and they called it life cost-based FMECA [67]
- **Pillay** and **Wang** reported several criticisms on FMECA such as the same RPN may be assigned to failures with different risk level [68].

The assign of value on severity, frequency and detection (S, O, D) is completely arbitrary and may point incorrect considerations. To overcome these criticisms, under literature review a new approach failure mode analysis is develop in which parameters as frequency, non-detectability, cost, severity, productivity and propagation have been taken into consideration. This approach finds out the riskiest parts of the offshore wind turbine based on these parameters and assigning different relation between parameters depending of the failure mode. This model has shown interesting results but data to validate the model has not been found and therefore the approach will not be shown. In order to compensate these criticisms, a cost study of the wind turbine components have been done. It improves previous studies in which better results could be achieved with a cost view. Moreover, criticality evaluation, risk matrix, mode criticalities are calculated through the classic FMECA approach, compared against RPN.

The classical FMECA approach can be seen along the time in [66], [6], [69], [70] [71], [72], [73], [74], [75], [76], [77], [78], [79], [80]. These papers and handbook are based under theoretical FMECA and it is explained deeply with the classical methodology. [72] explains the classical methodology by the U.S. military which was the founder of the method in 1940.

Then the classical FMECA is developed for our offshore wind turbine. It is supplemented with a Cost Analysis in order to cover the deficiencies founded through the bibliography.

2.3 Review maintenance approaches

Maintenance approaches are important if the profits of wind energy want to be higher. There are publications about maintenance plans. Preventive maintenance is based on fixed and scheduled maintenance tasks which could be defined for each component. For example, lubrication tasks are fixed and not innovations are required. Under a deed study, the components are analysed better and possible failure modes and failure rates come out. Those results are important for a preventive maintenance and these steps are neglected for some publications. Important publications regarding Reliability Centered Maintenance (RCM) and maintenance can be found in the bibliography that will be explained. The methodology selected is based on values coming from the classical RCM methodology [81] and [82] but based on previous deep studies of reliability and failure modes. It points out risks part of the wind turbine which are useful for the cited RCM methodology. From each literature has been taken knowledge or looked the criticism and doubts of similar studies. A maintenance literature review is done through the following points:

- **Kerres** and **Fischer** develops a life cycle cost, maintenance analysis and a sensitivity analysis. This report doesn't apply the methodology and only explain the approaches. Costs are not indicated and neither maintenance

tasks. Important parameters with the sensitivity analysis that affect the wind turbine are explained [83].

- **Igba** has developed a very theoretical journal paper regarding the Reliability Centred Maintenance. This information has been taken into account for our maintenance plans [84].
- **Jessen** develops a model which generates costs of inspections, repairs and energy losses. This model is based on too many random parameters and assumptions. The influence of parameters on maintenance costs has been taken into account for our model [85].
- **Yssaad** develops a RCM applied to power distributions systems. This journal papers explain the methodologies of FMECA and RCM. Costs of the maintenance tasks are pointed out. It is developed for a small power system. All concepts of this document have been analysed and studied more deeply. The FMECA doesn't generates a high number of failure modes tasks and therefore low number of maintenance tasks [86].
- It is a Reliability Centered Handbook from Naval Sea System Command. It is a very theoretical document that has served as support for the thesis [87].
- **Dalgic** tries to improve the O&M activities through a Monte Carlo model. Several possible maintenance sceneries (climate, transportation methods, etc) are analysed looking to improve the cost. This paper has been very useful in order to know the best O&M tasks for each wind turbine system [88].
- **Frans** develops a model to estimate O&M costs for onshore wind turbines. This report has been useful to compare O&M costs. The costs selected for this thesis have been compared and studied through all literature cited [89].
- This document from NREL institution has mainly been very useful for our O&M costs. Operations and maintenance strategies has been explained and have been considered. Failure frequency of the main wind turbine parts are shown but are very general and doesn't go deeper into components [90].
- **Besnard** has developed a thesis based on maintenance strategies and condition monitoring systems based on Artificial Neural Networks (ANN). The condition monitoring systems analysed temperatures of different wind turbine component. ANN is a reliable methodology which can be used in several fields with great results. In that case, ANN predict further loads and temperatures of wind turbine components. It is done in aeronautical sector with good results. It has been taken into account for maintenance strategies and for the developed SHM system but both systems are designed for different purposes [91].
- Firstly, the types of maintenances are presented and how can help to condition monitoring systems. Optimization of maintenance strategies are proposed trying to reduce the costs. This document has been useful in order to take decision about O&M tasks [92].
- It is a whole study starting from maintenance activities, spare parts, logistic, economic parameters, etc. Moreover, a model is developed of these aims. This literature is out of the main scope of the thesis and has been analysed for background parameters of the thesis [93]

- **Gustavsson** develops a deep study comparing different maintenance scenarios against cost. O&M can change highly depending on the selected maintenance strategy. It has to be useful por out maintenance tasks cost [94].
- **Matti** figures out how different parameters (weather, wave height, etc) influence to the availability of the offshore. It takes into account a low number of parameters [95].
- These reports are coming from one of the biggest wind turbine manufacturers. It has been useful in order to know deeper the wind turbine and to increase the number of maintenance tasks for each failure modes [96] [97].
- It is not considered due to the preventive maintenance plans is developed when a failure in a component comes out. The preventive maintenance plan tries to prevent failures and not to repair the failure when it is induced [98].
- Explain theoretically the maintenance plan focused in costs and how influence the weather parameters [99].
- It is a real project with real information regarding offshore wind turbines. This information has been used punctually during the thesis [100].
- **Miedema** develops a complete O&M analysis. It takes into account aspects as: technical, logistical, financial and the year scenario. It is not focused under the same maintenance objectives and therefore it has been useful in order to analyse maintenance aspects for the made assumptions [101].
- This [58] journal paper is an overview of maintenance approaches and future perspectives. A deep read is always recommended in order to know around the field. Hockley presented the current maintenance situation and future objectives.
- **Martin** develops a sensitivity analysis of farm operations and maintenance based on availability and costs. There are similar publications regarding that as has been said before. It provides useful information for the cost analysis that has been used [102].
- Sparse parts are not explained through this thesis but depending of the component or the agreements, sparse parts are needed close to the wind farm. Sparse part planning is explained in [103] by **Tracht**. Moreover **Lewandowski** [104] develops a similar study in order to reduce the costs as much as it is possible depending on the wind farm.
- [105] shows an overview of operations and maintenance issues.
- The maintenance costs study has been developed through a deep literature review. Matthias developed a deep cost study of a maintenance plan. Several maintenance perspectives are analyzed such as types of transportation, number of technicians...etc. [106].

The RCM analysis starts with a deep functional failure of all wind turbine component. The developed FMECA through the thesis is formed by six hundred pages which will be attached as an external document. It will be attached as a appendice. Maintenance plans of the bibliography are very theoretical and doesn't apply the methodology to the equipment. Through this maintenance study, two maintenance proposals are explained and applied to the wind turbine. One is based

on reliability analysis and FMECA analysis developed and then you could follow how the functional failures of the equipment are fixed with the right maintenance task. Moreover, the Condition Monitoring System is designed in order to form the Condition Based Maintenance for wind turbines blades.

Condition monitoring and prognosis challenges are treated by **Idriss**. A literature review of SHM techniques is done at the beginning of the journal paper. It is very theoretical paper and is explaining the steps to achieve a SHM system. In the section is explained how is applied the CBM and what aim has to be fulfilled in the SHM system [107].

There are reliable and tested SHM methodologies in several fields. For example, bridges monitoring and rotatory machinery (gearbox for example). For monitoring bridges, there are publications such as [108]. SHM applied to rotatory machine is based on the study of peaks in the FFT of the signals. This methodology works very well and failures can be forecasted.

There are a lot of publications regarding damage detection ever in metallic panels. In metallic material, guided waves work better and waves travels uniformly through the material. An example of that can be found in 108. The reliability of the methodology in metallic structures is higher due to the behaviour of the guided waves are more studied and don't change along the structure.

For composite material, it is more difficult than for metallic materials. Moreover, blades present bays and stringers which could change the behaviour of the waves. Moreover, compression and traction loads have been taken into account simulating real conditions. The proposed panel is made by an acoustic insulation and it hinders the test. A test with these environmental conditions has not been found. Blades design has curves which may complicate the methodology but it has also been tested in panel curves. The characteristics of the composite material used are similar with the blades composite.

The SHM level looked in order to achieve the final objective are:

- Detection: damage detection is the most difficult step because the other are based on this SHM level. There are a lot of methodologies and approaches for damage detection in composite panel. Literature review of this SHM level has been done, looking to gain a background of the available methodologies. The methodology explained in this thesis is based on basic statistics and being able to detect the damage in composite material under difficult conditions [109], [110], [111], [112], [113], [114], [115], [116], [117], [118], [119], [120], [121], [122]. These publications have not been used for the methodology developed.
- Location
- Assessment
- Damage prognosis

There are a lot of published methodologies regarding this damage detection in composite material. The developed methodology is based on the comparison of signal of two state condition, the healthy structure against the damaged structure. Methodologies come out regarding the method of the comparison between these two signals. Through this thesis, classical statistics are used, achieving good results due to the damage is detected and is located with a high accuracy. There are other methods that try to magnify this different between signal and then it points out if the

structure is damaged. The main aim is to select the best and easy way to develop this methodology. If the classic statistic works well, other known methodologies are neglected.

An important part of the RCM is the CBM. The CBM was born in 1940 by Rio Grande Railway Company which improved the profits and failure rates were reduced. The disadvantage of the CBM is the great investment made at the beginning. The CBM is created during the design and development phase and it is getting better during the life cycle. CBM is a failure management methodology for a specific failure mode. The riskiest failure mode will be selected (blades failure).

CBM methodology has been used for sixty years and therefore it is based on known steps. The novelty methodology comes from the Structural Health Monitoring system used which is based on novelty detection and location of damages.

3 Reliability Analysis

3.1 Reliability Engineering (RAMS)

3.1.1 Reliability – Basic Concepts

Reliability:

Reliability can be defined as “the ability of an item to remain functional”. Reliability is the conditional probability that an equipment will perform without failure its intended functions satisfactorily, at a given age and for a specified length of time (mission time). From another point of view, reliability could be defined as the ability of an item to remain functional.

Some reliability’s characteristics are:

- Reliability is applied to non-repairable as well as to repairable items.
- The definition of the required function is the starting point for any reliability analysis.
- The required function and operating conditions can also be time dependent.
- The reliability function is defined as $R(t)$ when the mission duration T is taken as parameter t .

Reliability concept is explained in the following section deeply.

MTTR

Mean time to repair (MTTR) is the time to complete the necessary repairs for a repairable system. It should be measured in time and hours. It is an important concept for the maintenance plan. Depending on the item, the time can be higher due to for example if preparation time is needed. Some elements of the MTTR are:

- Preparation time
- Fault isolation time
- Disassembly time
- Reassembly time
- Alignment time
- Checkout time
- Start-up time

Availability

The Availability of a system is the probability that the system is operating satisfactorily along the time when it is working under stated conditions. Availability is explained deeper in the following sections.

3.1.2 Failure

Failure could be defined as the events or inoperable state, in which an item doesn't perform its function as previously specified. A failure can be classified depending of mode, cause and effect. Moreover, failures are also classified as:

- Catastrophic
- Degradation
- Drift
- Intermittent
- Combination of the above

3.1.3 Failure Rate

The rate of occurrence of failures is measured by failure rate. The number of failures in specified time period (failure rate) is usually measured by failures per million hours.

Assume that n statistically identical, independent items are put into operation at time $t=0$ under the same conditions, and that at the time t a subset $v(t)$ of these items haven't failed yet:

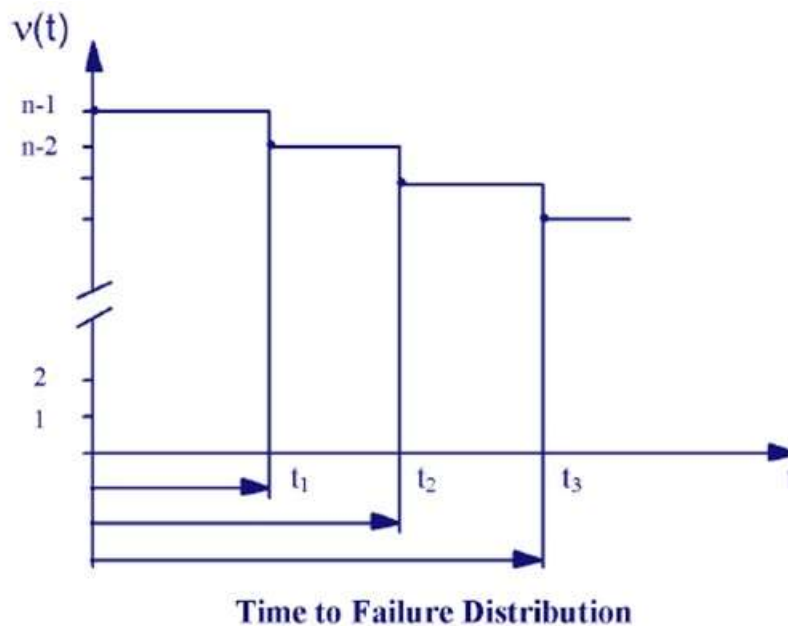

Figure 3. *Time to failure distribution*

The Figure 3 shows as $\bar{v}(t)$ is a right continuous decreasing step function and t_1, \dots, t_n are the observed failure-free operating times of the n items. As stated above, they are independent realizations of a random variable τ is considered here as the item's failure-free operating time.

The expression:

$$\hat{E}(\tau) = \frac{t_1 + \dots + t_n}{n} \quad 3.4$$

is the empirical expected value or empirical mean of t and for $n \rightarrow \infty$. $\hat{E}(\tau)$ converges to the true value of the mean failure-free operating time $E(\tau)$. The empirical reliability function is:

$$\hat{R}(t) = \frac{\bar{v}(t)}{n} \quad 3.5$$

$R(t)$ converges to the reliability function $R(t)$ for $n \rightarrow \infty$ and the empirical failure rate is defined as

$$\hat{\lambda}(t) = \frac{\bar{v}(t) - \bar{v}(t + \delta t)}{\bar{v}(t)\delta t} \quad 3.6$$

Where

$$\hat{\lambda}(t)\delta t \quad 3.7$$

is the ratio of the items failed in the interval $(t, t + \delta t]$ to the number of items that have not yet failed at the time t .

Applying Eq. (3.5) to Eq. (3.6) and dividing by n :

$$\lambda(t) = \frac{R(t) - R(t + \delta t)}{\delta t R(t)} \quad 3.8$$

For $n \rightarrow \infty$ and $\delta t \rightarrow 0$ in such a way that $n\delta t \rightarrow 0$, $\hat{\lambda}(t)$ converges to the failure rate

$$\lambda(t) = \frac{-dR(t)/dt}{R(t)} \quad 3.9$$

Equation (3.9) shows that $R(t)$ is derivable and it shows that the failure rate $\lambda(t)$ determines the reliability function $R(t)$. Integrating this differential equation with the condition $R(0) = 1$:

$$R(t) = e^{-\int_0^t \lambda(x) dx} \quad 3.10$$

In a lot of applications, the failure rate can be assumed to be nearly constant (time independent) for all $t \geq 0$, then is assumed:

$$\lambda(t) = \lambda$$

From Eq. (3.10) then:

$$R(t) = e^{-\lambda \cdot t} \quad 3.11$$

The mean of the failure-free operating time is given in general by

$$MTTF = E[\tau] = \int_0^{\infty} R(t) dt \quad 3.12$$

where MTTF stands for mean time to failure. In the case of a constant failure rate $\lambda(t) = \lambda$, $E[\tau]$ assumes the value.

$$E[\tau] = \int_0^{\infty} e^{-\lambda t} dt = 1 / \lambda \quad 3.13$$

It is common usage to define $MTBF = \frac{1}{\lambda}$ and it is defined as the mean operating time between failures. The failure rate of a large population of items often exhibit the typical bathtub curve depicted in Figure 4.

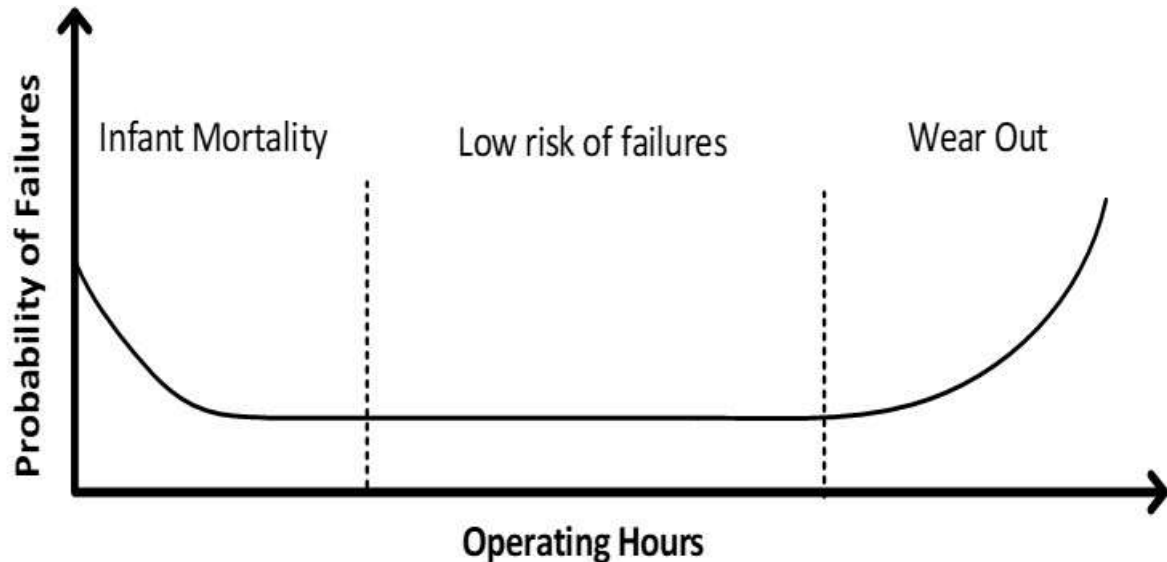

Figure 4. *Bathtub Curve: typical shape of the failure rate on items*

The Bathtub Curve shows three phases:

1. Early failures: $\lambda(t)$ decreases rapidly with time. Failures in this phase are generally attributable to randomly distributed weaknesses in materials, components, or production processes.
2. Useful life with constant failure rate: $\lambda(t)$ is approximately constant and equal to λ . Failures in this period are Poisson distributed and often cataleptic.
3. Wear out failures; where $\lambda(t)$ increases with time. In this phase, failures are usually attributable to aging, wear out, fatigue, etc.

The effects of this work time can affect on the reliability. If the mission of a system wants to be change for t hours, the concept of Conditional reliability has to be introduced. T accumulated operational hours are supposed for the system. Then the reliability of the system can be written:

$$R(T+t) = R(T) \times R(T,t) \quad 3.14$$

And solving the $R(T,t)$:

$$R(T,t) = R(T+t) / R(T) \quad 3.15$$

Using the eq. (3.10):

$$R(T, t) = e^{-\int_T^{T+t} \lambda(x) dx} \quad 3.16$$

For the exponential case:

$$R(T, t) = e^{-\lambda t} \quad 3.17$$

3.1.4 Reliability Function

The failure probability density function can be called time to failure function and is denoted as $f(t)$. It expresses the probability that the system fails along the time. If the system is new and is installed into the system and therefore time is assumed as 0. It can be shown as:

$$\int_0^{\infty} f(t) dt = 1 \quad 3.18$$

If the probability of failure between a fixed time $[0, t]$, the expression would be:

$$F(t) = \int_0^t f(\tau) d\tau \quad 3.19$$

But the reliability of a system has to be analysed after the time t and it is expressed as:

$$R(t) = \int_t^{\infty} f(\tau) d\tau = 1 - F(t) \quad 3.20$$

And therefore:

$$\lambda(t) = \frac{-dR(t)/dt}{R(t)} \quad 3.21$$

If the probability of failure λ comes out:

$$\lambda(t) = -\frac{dR(t)}{R(t)dt} = \frac{f(t)}{R(t)} \quad 3.22$$

The density function can be applied to several curves such as:

- Exponential
- Normal
- Lognormal
- Weibull
- Rayleigh
- Uniform
- Time Independent

The reliability function is depicted in the following Figure 5 where is represented how to evolve the reliability with the time.

These density function are useful to study the reliability life of a system and therefore the curve has to be selected based on the reliability of the system. The density function curve has to fit into de reliability data. Exponential curve is used to explain our data along the time. The exponential distribution function looks like to the Figure 5.

The exponential distribution is the simplest way to describe the reliability life of a component. The data base used for this study has been tested in order to look which is the best distribution and which fit better. If the reliability data is constant along the time, the exponential distribution is a good option to describe the reliability life. For the exponential distribution, the mean time to failure is the reciprocal of the failure rate. The failure probability density function based on exponential distribution can be expressed as:

$$f(t) = \lambda e^{-\lambda t} \quad 3.23$$

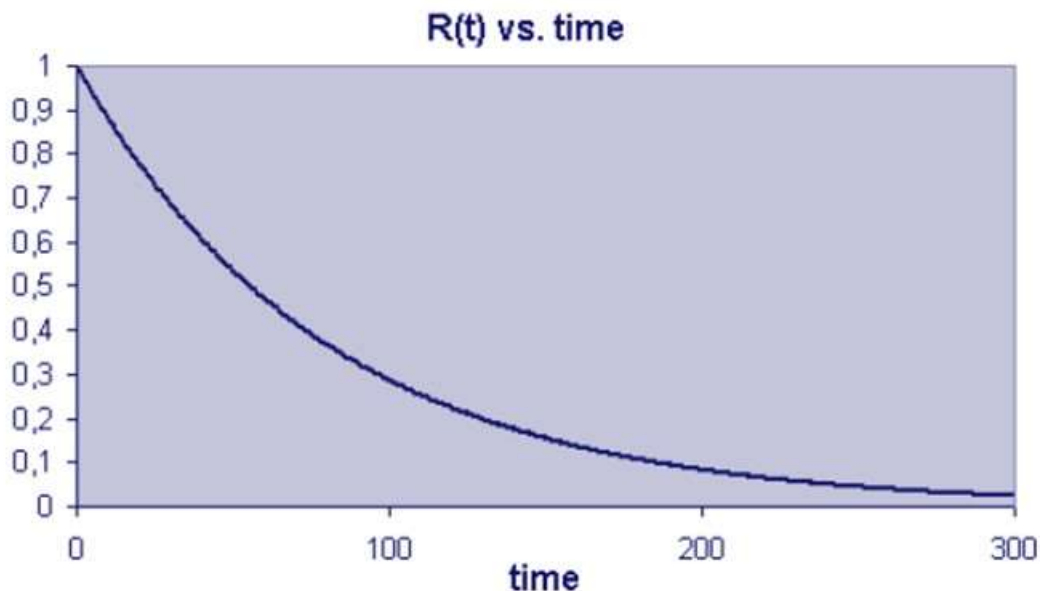

Figure 5. *Reliability Function*

At time $t=0$, no components have failed and then the value of reliability is 1. For $t>0$, some items might fail and the value of reliability decreases below 1 and it will tend to 0.

The general formulation for the reliability is:

$$R(t) = e^{-\int_0^t \lambda(x) dx} \quad 3.24$$

As has been said before, if we consider that failure rate is constant along time:

$$\lambda(t) = \lambda \quad 3.25$$

Finally, the reliability function can be expressed as:

$$R(t) = e^{-\lambda t} \quad 3.26$$

3.2 Reliability Analysis Procedure

Reliability, availability, maintainability and safety on the WTG should be built during the design and development phase. The procedure for developing the reliability analysis is depicted in the Figure 6.

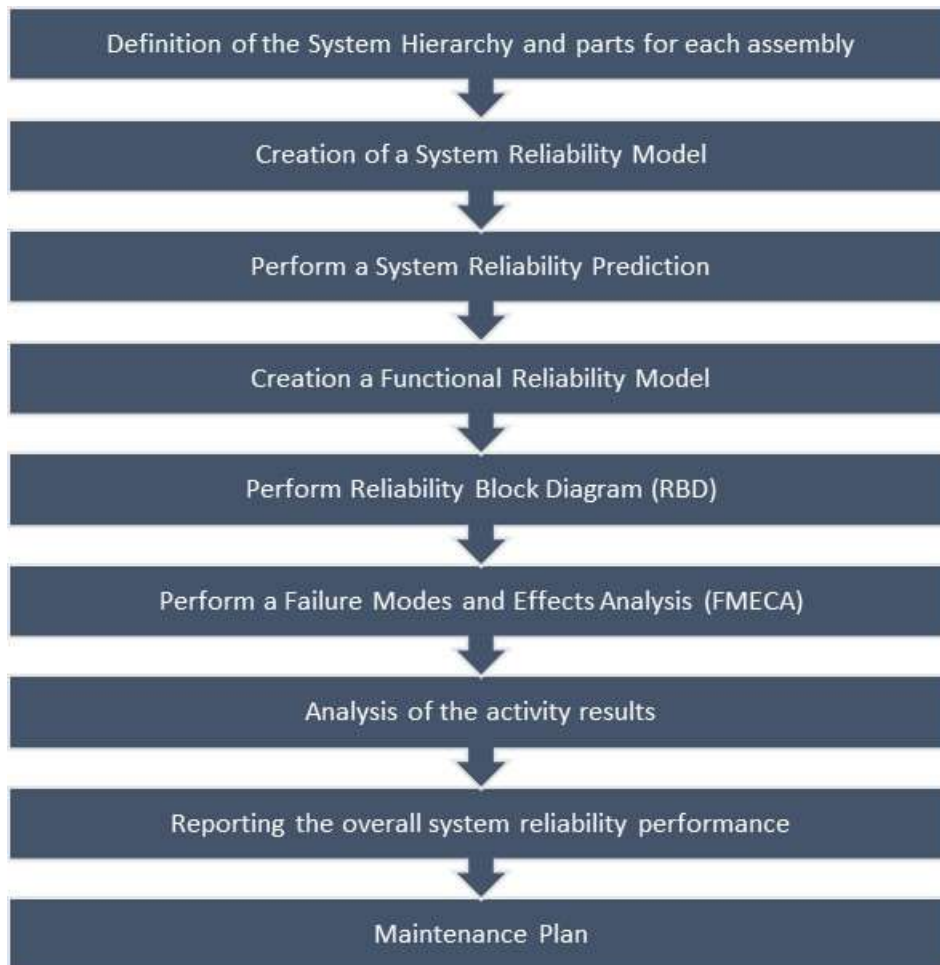

Figure 6. *Reliability Analysis Procedure*

In order to realize the reliability design, every step must be carried out and the overall purpose for the reliability analysis will be achieved through of:

- Identify, evaluate and document component failures, potential impact of each functional or hardware failure on sub-system and systematic level.
- Design and develop possible redundancy at component level, to ensure that failures propagation is contained at component level and that ultimate effects don't impact on the availability of WTG.
- Obtain the information necessary for design improvement.
- Ensure realization of the inherent safety and reliability levels of the system.

3.3 Reliability Model

The reliability model is the 10MW Offshore Wind Turbine. This offshore wind turbine can be designed through several configurations. The configuration is explained in the following section. The whole offshore wind turbine through assemblies and sub-assemblies is shown in the Figure 7.

3.3.1 Offshore Wind Turbine configuration

The offshore wind turbine consists of a number of individual pieces of equipment (mainly mechanical), each designed to perform a particular function on the wind turbine, such as:

- To extract kinetic energy from the wind and to transform it into electrical energy.
- To transfer the electrical energy generated by the generator to the electrical grid.
- To fulfil safely these tasks during its life remaining functional for 20 years considering dedicated and acceptable maintenance.

There are several wind turbine configurations [123], [124], [125], [126], [127] which has been studied. A literature review has been done and the best option has been selected. shows the whole hierarchy system which has been used in order to develop the reliability model. Main assembly and sub-assembly characteristics have been described as follows:

The Rotor Module is composed of a hydraulic pitch system which optimizes the position of the blades based on the wind direction. It is also the primary brake system for the wind turbine.

The Drive Train Module transmits wind forces and torque from the rotor to the main shaft. It is done through a gearbox which is a combination of a planetary stage, followed by two parallel stages, and a mechanical brake. Four electrical yaw gears with motor brakes are included into the Nacelle

The Yaw System rotates the top part of the nacelle into the upwind direction to maximize power production and minimize loads.

A doubly fed induction generator (DFIG) with rated power 10 MW Power Module has been selected.

A converter is connected between the generator and the grid. It is a four-quadrant converter with the insulated gated bipolar transistor (IGBT) on the generatorside. An active crowbar unit is placed on the generator-side to ensure the compliance with grid requirements. The converter is located in the rear part of the nacelle.

The wind turbine configuration is shown in the following Figure 8.

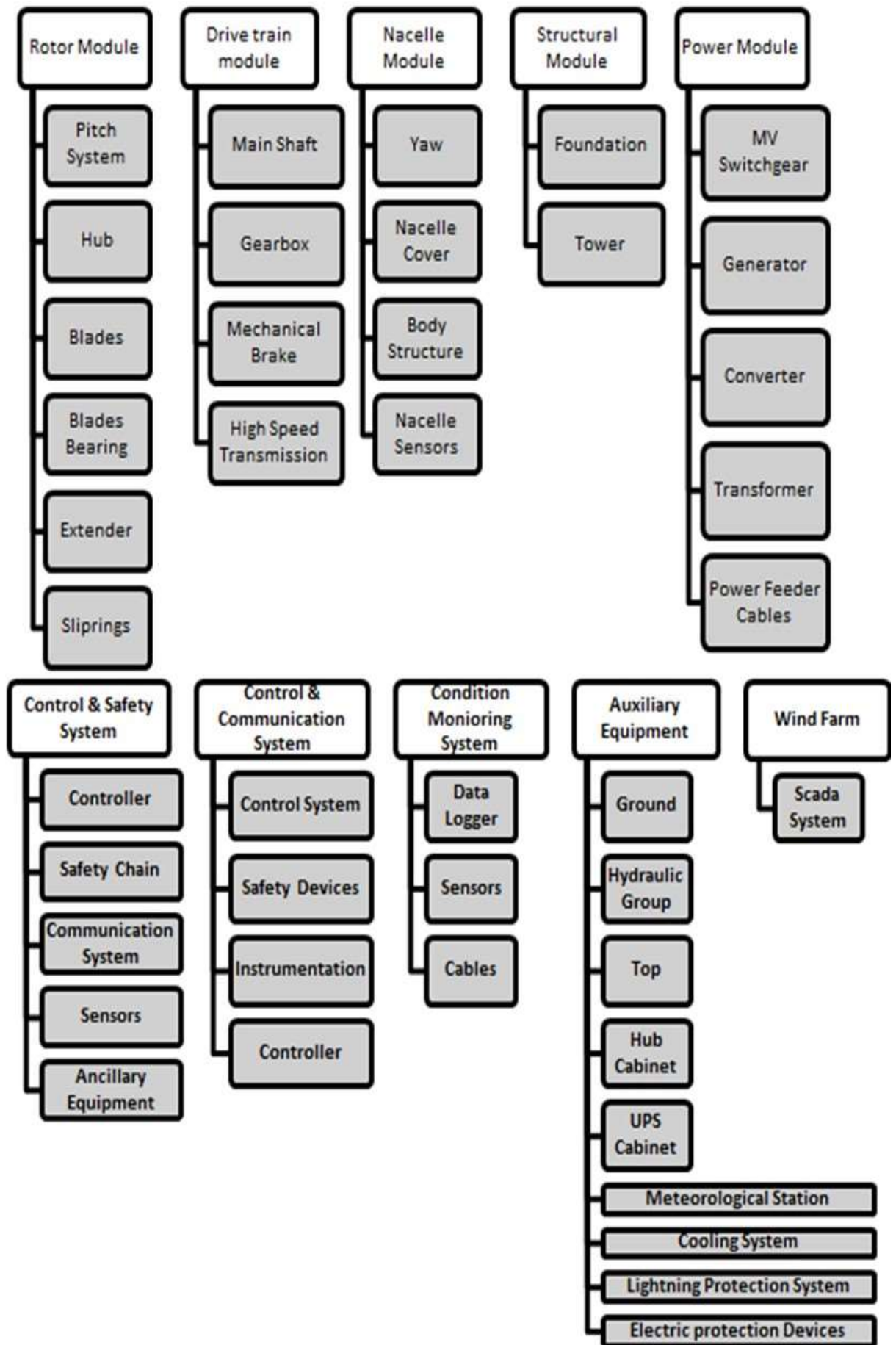

Figure 7. Whole hierarchy offshore wind turbine

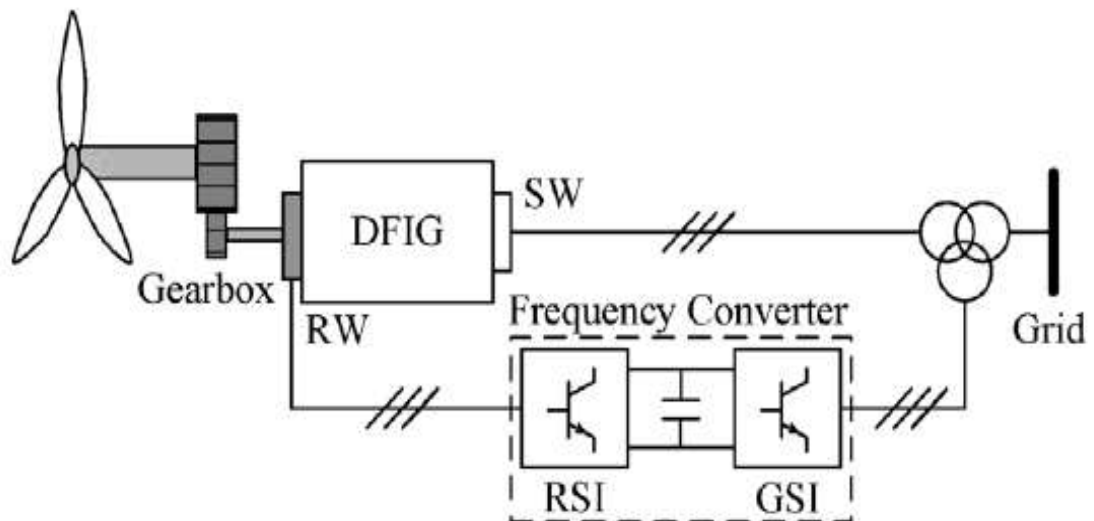

Figure 8. *Wind Turbine with DFIG (doubly fed induction generator) [125]*

These primary functions are realized with the main following elements at assembly and sub-assembly level:

Rotor Module

Hydraulic Pitch System: The function of the pitch system is to optimize the position of the blades based on the wind conditions to the optimum pitch angle. It is also the primary brake system on the wind turbine. The optimum pitch angle is achieved depending on the gearbox input velocity and the wind conditions. The gearbox needs an adequate input velocity in order to get the right output velocity. The wind turbine could work extremely under strong gusts of wind or however it could need to increase the rotation speed. The offshore wind turbine presents several systems in order to improve or reduce the acquired wind such as: pitch system and yaw system. Hence the optimum pitch angle can be used either to reduce or increase the rotation speed. The turbine has a meteorological station and therefore the wind direction is one of the calculated metrics. A proper pitch angle will generate more energy acquisition. The pitch system can be used as a breaker in case the rotate wind velocity is out of range. The hydraulic pitch system can be seen in Figure 9.



Figure 9. *Hydraulic pitch system*

Blades: Each blade consists of a load carrying spar cap integrated on the shells with two shear webs build separately. The blades are designed for optimised output and minimised noise and light reflection. Blade design should minimize the mechanical loads applied to the turbine then less stresses through it.

Blade Bearings: The blade bearing is a double raced 4-point ball bearing bolted to the blade hub. Each bearing has automatic lubrication system.

Drive Train Module

The drive train transmits wind forces and torque from the rotor to the main shaft.

Gearbox Assembly: The gearbox is a combination of a planetary stage followed by two parallel stages with a total ratio of approximately 100.

Mechanical Brake: This brake is hydraulically activated and is installed in the high-speed shaft of the gearbox. The Mechanical brake works as emergency and parking brake:

Emergency: when the turbine is running and one of the emergency buttons is activated, the Mechanical Brake supports the pitch system of rotor blades (full-feathering).

Parking brake: when rotor needs to be stopped for maintenance reason.

Nacelle Module

Yaw System: The system enables the nacelle to rotate on top of the tower into the upwind direction to maximise power production and minimise loads on the nacelle and untwist medium voltage cables when the nacelle turning is accumulated in one direction. Four electrical yaw gears with motor brakes rotate the nacelle. The yaw system is shown in the Figure 10.

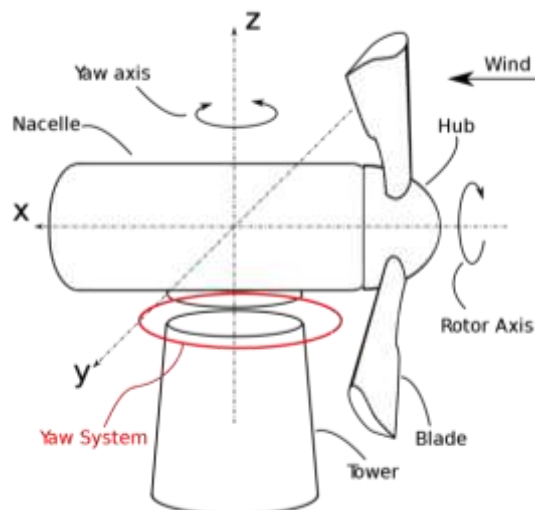

Figure 10. Yaw system

Power Module

Generator Assembly: The generator is a doubly fed induction generator (DFIG) with rated power 10 MW.

Converter: The converter is connected between the generator rotor and the grid, and it is a 4-quadrant converter with IGBT generator-side and grid-side inverters converter with an active crowbar unit on the generator-side to ensure the compliance with Grid Code requirements. The grid-side and generator-side inverters are IGBT based and linked by a capacitor bank DC link. The converter is located in the rear part of the nacelle.

Transformer: The step-up transformer is rated depending on the grid connection and is located in the nacelle. The transformer is a three-phase dry-type cast resin transformer and air cooled.

Control & Communication System

For regulation and supervision of the turbine and generator, there is the control system consists. The function of this system is to control the pitch, the yaw and generator excitation to maximize the power output for any wind condition, minimizing loads in the WTG and guarantee the WTG protection on emergency and fault conditions.

Auxiliary Equipment

Hydraulic System: A Hydraulic Power Units provides pressure for the pitch, the yaw and the mechanical brake and the rotor locking mechanism, so the common components to these systems are included in the hydraulic system.

Lightning Protection System: The system prevents the blades and the nacelle, including bearings, gearbox, generators, control systems, auxiliaries and monitoring equipment, from damage by the lightning currents.

WTG Meteorological Station: Include all the sensors that provide information about meteorological conditions. Primarily temperature, wind speed and direction.

Wind Farm System

The WTG monitoring signals are integrated into a Supervision, Control and Data Acquisition system (SCADA), which allows users to access the wind farm.

It should be capable of communicating quickly and reliably with any wind farm topology based on modern Ethernet network technologies. It also allows the integration of wind farm installations like electrical substations, reactive power equipment, capacitor banks and more.

The WFS includes the following overall functions:

- Monitoring
- Control
- Data collection
- Reports
- Management and security
- Configuration

The main characteristics of the studied offshore wind turbine are shown in Table 2:

Configuration Criteria	DTU 10MW offshore
<i>Rated Power</i>	<i>10MW</i>
<i>Rotor Diameter</i>	<i>178.3 m</i>
<i>Wind Regime</i>	<i>IEC Class 1A</i>
<i>Rotor Orientation Control</i>	<i>Clockwise rotation- Upwind Variable Speed. Collective Pitch</i>
<i>Cut in wind speed</i>	<i>4 m/s</i>
<i>Cut out wind speed</i>	<i>25 m/s</i>
<i>Rated Wind Speed</i>	<i>11.4 m/s</i>
<i>Hub Diameter</i>	<i>5.6 m</i>
<i>Hub Height</i>	<i>119 m</i>
<i>Drivetrain</i>	<i>Medium Speed, Multiple-Stage Gearbox</i>
<i>Generator</i>	<i>Doubly Fed Induction Generator (DFIG)</i>
<i>Maximum Generator Speed</i>	<i>480.0 rpm</i>
<i>Minimum Rotor Speed</i>	<i>6.0 rpm</i>
<i>Maximum Rotor Speed</i>	<i>9.6 rpm</i>
<i>Maximum Tip Speed</i>	<i>90 m/s</i>
<i>Number of Blades</i>	<i>3</i>
<i>Rotor Mass</i>	<i>227,962 kg</i>
<i>Nacelle Mass</i>	<i>446,036 kg</i>
<i>Tower Mass</i>	<i>628,442 kg</i>

Table 2. *Offshore Wind Turbine Description*

A global view of the offshore wind turbine assemblies can be seen in the Figure 11. This Figure 11 and the last Table 2 show the aerodynamics and structural mechanics of the offshore wind turbine.

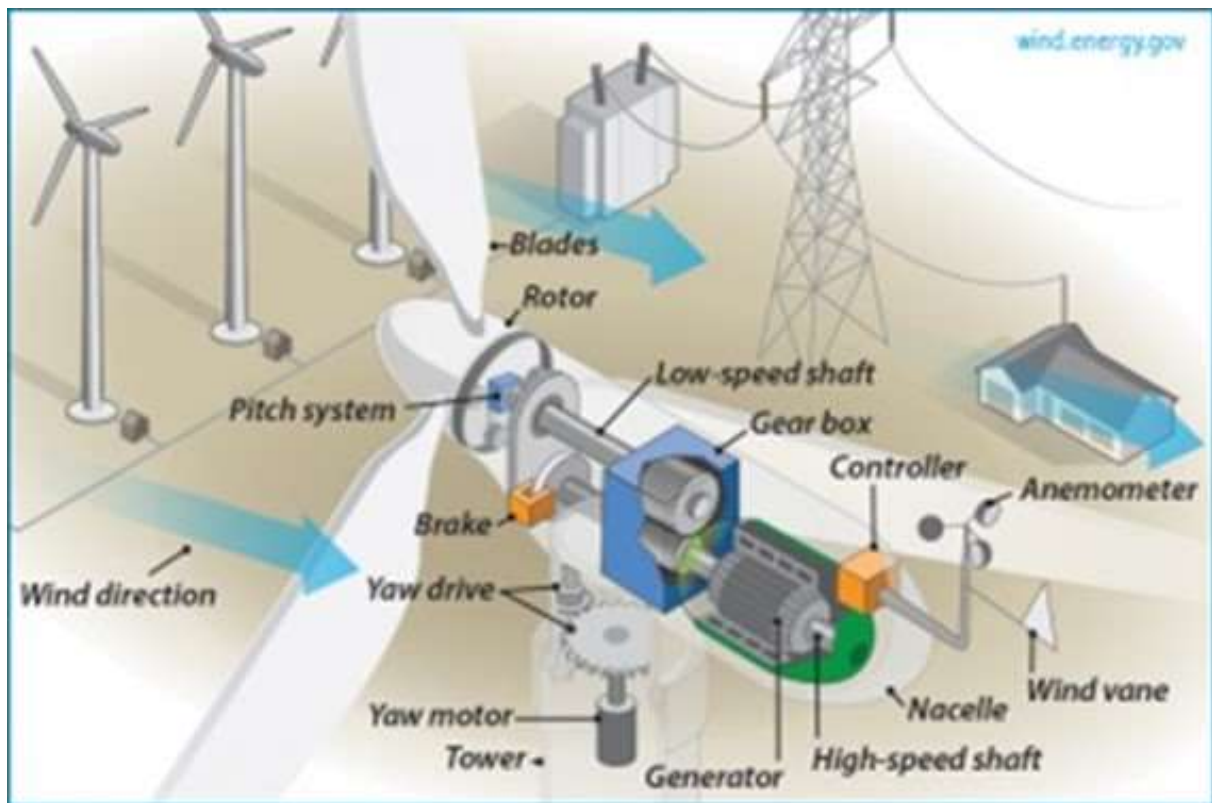

Figure 11. *Wind turbine systems. [Wind Energy Technologies Office]*

The starting point for a wind turbine is the blade design. The size of the blades determines the capacity factor of the turbine. More parameters affect to the capacity factor but it is one of the importants. The main rule is that a larger diamneter, the greater is the energy output of the turbine. In order to achieve 10MW, great blades dimension has to be designed. Betz law means that the wind turbine can only take the 59.3% of the kinetic energy of the wind. The size of the turbine is not an aim of this assumption. Due to the wind turbine can not be designed perfectly, the capacity factor can not be the 59.3% and unfortunately it will be lower. Then the blades take one of the most important aim of this turbine and for this reason is taken into account deeply in all studies developed.

3.4 Reliability Prediction

Reliability prediction is a quantitative analysis technique that has been used to predict the failure rate of an offshore wind turbine (OWT) using an established model with defined operating conditions. The goal of reliability prediction is to predict the rate at which components and systems fail.

It is one of most common technique for reliability evaluation and this analysis is usually carrying out by standards model developed by several national and international organization (data-bases).

The prediction has been done by part count method. This reliability model includes every component as series model in which the reliability prediction is calculated by the sum of failure rate of every components.

One aim of this research is to look the right reliability data base in order to achieve goals as:

- Failure Rate
- MTBF
- Reliability
- MTTR
- Availability

Carrying out the reliability prediction, general assumptions have been taken and several steps are defined.

3.4.1 General Assumptions

- Failure rates of components are constant during equipment life period. The component time to failure distribution is exponentially distributed (a constant failure rate).
- The failures of different components are considered independent.
- The system reliability model is serial, therefore failure of any component causes system failure.
- The failure rate prediction only takes into account hardware failures and excludes software failures.
- The failure rate prediction makes no statement of the predicted lifetime for the sub-system considered. Mechanical sub-system population life is driven by wear-out mechanisms or retirement by obsolescence.
- The predicted failure rate isn't precise but rather an approximate estimate.
- Component failure rates do not include early life or end of life failure mechanisms but only the steady state part of life.

3.4.2 Reliability Prediction steps

1. Select the prediction data source.
2. Define the system
3. Define the components
4. Calculate
5. Generate outputs

6. Review results

3.4.3 Definition and Assumptions

The general formulation for the reliability through time is shown as Eq. (3.27):

$$R(t) = e^{-\int_0^t \lambda(x) dx} \quad 3.27$$

Where R is the reliability and λ is the failure rate (number of failures per million of hours) and t is the time.

A component's lifetime is often described by three phases. During first phase, the failure rate decreases down early with time and failures are attributable to manufacturing and quality problems. After that in the second phase, failure rate $\lambda(t)$ is approximately constant (chance failures). In the third phase, the failure rate increases with time due to aging, wear out, fatigue, etc. If it is assumed that the failure rate is constant along time (2nd phase), we get Eq. (3.28):

$$\lambda(t) = \lambda \quad 3.28$$

Using Eq. (3.28), the reliability function shown in Eq. (3.27) can be expressed as Eq. (3.29):

$$R(t) = e^{-\lambda t} \quad 3.29$$

The reliability exponential function (Eq. 6.3) has been selected as the way to describe the component's reliability.

3.4.4 Reliability Prediction Data-Base

Since published reliability data of offshore wind farms does not exist, it has been necessary to convert the failure rate data from onshore to offshore using published data of onshore wind turbines. Before starting the reliability prediction, a literature review of published data sources (e.g. Windstats, WMEP, LWP and Swedish Wind) was conducted, and the Reliawind data-base was chosen as being the most suitable for this research.

Then it is assumed that the best available database that the reliability prediction can use in order to develop the best reliability study is the database from Reliawind project. It is a project of two onshore wind turbines but newer than the rest of data sources and also has more nominal power. In order to convert data from onshore to offshore, a updated from Reliawind's turbine to DTU-10MW turbine will be done in order to convert data from onshore to offshore. Also, a conversion factor will be applied because the environment and stresses are different. Anyway, the quality improvement of components hasn't been taken on consideration and it should had done a reduction of failure rate.

3.4.5 Wind Turbine Failure Data Source

Reliawind is a project in which the reliability of large wind turbines (5 MW) was investigated. Recommended methods of measuring reliability and processing data from onshore wind turbines and wind farms were studied. During this project a large

data-base, containing data on more than a thousand items, was developed. The project ran from 2008 to March, with active involvement of ten partners.

Hence Reliawind is a European Project where was carrying out reliability studies on 2 Onshore Wind Turbines, R80 and R100. These two onshore turbines have a hydraulic pitch system for turning the blades, 3-stage gearbox and a doubly feed induction generator (DFIG). These two onshore wind turbines are explained in the following Table 3.

Main Data	R80	R100
<i>Nominal Power</i>	<i>2 MW</i>	<i>5 MW</i>
<i>Rotor Diameter</i>	<i>80-90 m</i>	<i>120-130 m</i>
<i>Hub Height</i>	<i>60-100 m</i>	<i>100-120 m</i>
<i>Rotational Speed</i>	<i>10-20 rpm</i>	<i>12-14 rpm</i>
<i>Aerodynamic Brakes</i>	<i>Full feathering</i>	<i>Full feathering</i>
<i>Number of blades</i>	<i>3</i>	<i>3</i>
<i>Class</i>	<i>IIA</i>	<i>IIA</i>
<i>Operating Temperature</i>	<i>-25+40°C</i>	<i>-20+40 °C</i>
<i>Altitude</i>	<i>0-1500 m</i>	<i>0-1500 m</i>

Table 3. *Description Onshore Wind Turbines Reliawind Project*

A study about which is the best data source was done and finally the data base from Reliawind is the best data that there is because:

- There aren't any publish offshore data-base, so it can only come from onshore data sources. Offshore data sources are only coming from manufacturer companies like Vestas, Siemens, Adwen, etc.
- As the specifications on Table 3 shows, these kinds of onshore data sources have been created since 12 years and the wind farms also have low power rating. Therefore, a study with this type of data base can't be done. On this time, the qualities of components have got better and there is a great different between 1,5MW and 10MW.
- A whole system hierarchy for each assembly is available on this data source.

3.4.6 Conversion Factor

Since our current turbine operates in a different environment, and has different parameters compared to the Reliawind turbine, a conversion factor has been introduced to convert the database data of the 5 MW *onshore* wind turbine to that of a 10 MW *offshore* wind turbine. This factor has been derived as combination of two parameters [52], [128]The first parameter "K1", takes into consideration the environmental stress; "K2" is based on the power rating stress.

- ***K1 offshore*** is the environmental stress factor and it is defined as the effect of environmental condition (e.g. weather and humidity condition) on the offshore wind turbine.
- ***K2 offshore*** is the power rating stress factor that depends on the operating power ranges of the wind turbine.

It is well known that offshore wind farms are exposed to higher power rating stress factor and adverse environment. Thus, Eq. (3.30) is used to describe the failure rate for the offshore wind turbine:

$$\lambda_{offshore} = \lambda_{onshore} \cdot (K_{1\ offshore} \cdot K_{2\ offshore}) \quad 3.30$$

Environmental Conditions	Environmental Stress factor K_1
<i>Ideal, static conditions</i>	0.1
<i>Vibration free, controlled environment</i>	0.5
<i>Ground-based</i>	1
<i>Naval Sheltered</i>	1.5
<i>Naval Exposed</i>	2
<i>Road</i>	3
<i>Rail</i>	4
<i>Air</i>	10
<i>Missile</i>	100

Table 4. *Environmental stress factor*

The Table 4 shows how the value of the environment stress conversion factors varies, depending on the environmental conditions.

In our case, K_1 is considered to be 'Naval Sheltered' for items within the nacelle. 'Naval Exposed' is chosen for the items that are fully exposed to marine environment. K_1 onshore is considered to be 'Ground Based' (K_1 onshore D1); K_1 offshore is assumed to be between naval sheltered and exposed ($1.5 \leq K_1 \text{ offshore} \leq 2$).

The other parameter, K_2 , is obtained by taking into consideration the 'windiness' of the wind farm site. The windiness of the OWT is measured by the capacity factor of the wind turbine. This average capacity factor is assumed to be 25% for onshore, 35% for near-offshore and 45% for far-offshore [129], [130], [131], [132], [133]; in our case, the wind farm is considered to be 'near-offshore'.

Table 5 shows the exponential relationship between the power rating stress factor and the component nominal rating. Values from Table 5 are plotted on Figure 12 and the equation of the curve can be derived from the values shown.

Percentage of component nominal rating (PCNR)	Power rating stress factor K_2
140	4
120	2
100	1
80	0.6
60	0.3
40	0.2
20	0.1

Table 5. Power rating stress factor for mechanical components

As per the previous considerations, the difference between the average capacity factor for 'far-offshore' and 'onshore' is 20% (45 %–25 %). Accepting a capacity factor of 25% as the average onshore (assumed as a PCNR value of 100%), and assuming that K_2 onshore is equal to 1 (from Table 5), the PCNR of far-offshore is calculated as: 45% - 25% + 100% = 120%.

Similarly, from Table 5, K_2 far-offshore is equal to 2, the PCNR of near offshore can be calculated by using the same method which has been used for the far-offshore case; assuming a near offshore capacity factor of 35%; the PCNR of near-offshore is then: 35%-25%+100% = 110%. K_2 near-offshore is then calculated through Eq. (3.31), using this PCNR value of 110%:

$$K_2 = 0.0541 \cdot e^{0.0301 \cdot \text{PCNR}} \quad 3.31$$

As a result, K_2 near_offshore is equal to 1.483. Then, Eq. (3.32) can be obtained by introducing K_2 near_offshore into Eq. (3.30):

$$\lambda_{\text{offshore}} = \lambda_{\text{onshore}}(K_{1 \text{ offshore}} \cdot 1.483) \quad 3.32$$

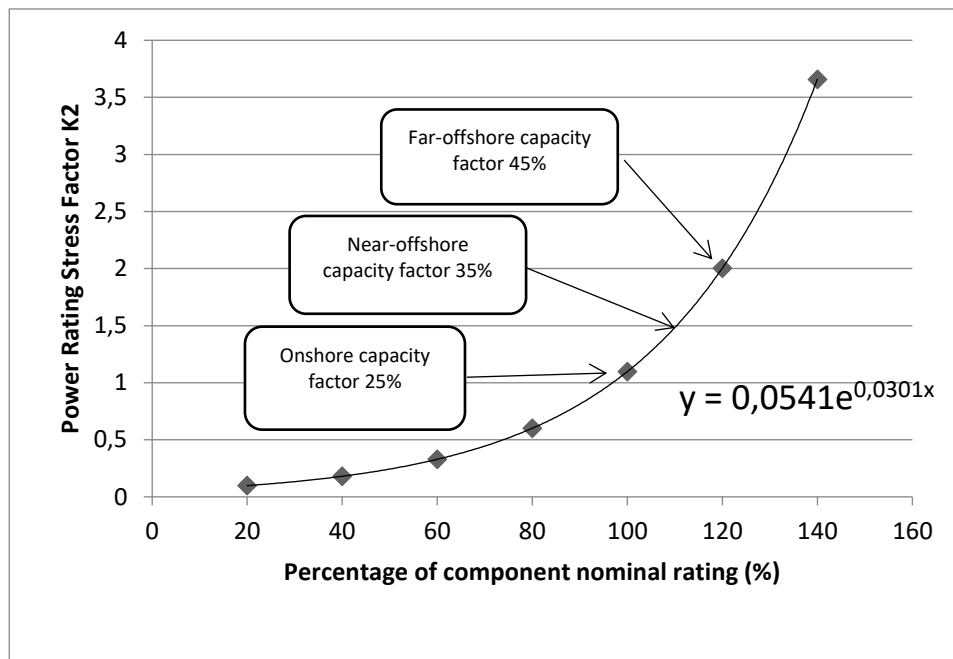

Figure 12. Percentage of component nominal rating plotted against stress factor K2. Graph constructed based on the data presented in Table 6

3.4.7 Reliability Prediction Results

The system failure rate value obtained from the reliability prediction analysis is **1866.36 failures per million hours**. Table 6 shows the number of failures per year associated with each sub-system (the failures of the auxiliary equipment are not included in Table 7). Some characteristics of the results have that:

- Look for high failure rates:
- Rotor Module has highest failure rate, followed by Control and Safety System, Control and Communications System and Drive Train Module. Rotor Module has highest failure rate because hydraulic pitch system is included there three times, each one within a blade and it has a great failure rate as Table 7 shows. Moreover, the hydraulic group is also included in the pitch system design. Then an excellent maintenance plan should be carried out in order to keep the system without failures and keeping high availability.
- Look for unexpectedly low failure rates: Under a deep view, there isn't any components with an unexpectedly failure rate.
- The predicted failure rates are plotted in the following Figure 13 and Figure 14 Wind turbines are subject to higher *environment, temperature, humidity, stress and sensitivity*. Then the failure rate of the system is increased, due to their location in marine environment and the high nominal power of the turbine (10MW), which will have more stresses and vibrations hence a higher failure rate. Moreover environment, humidity and temperature will be more pronounced and therefore these factors will make a wind turbine with higher failure rate as figures show.
- Non-consider redundancy: Such as reliability prediction has been done, it isn't possible to show within this method the real condition of the wind turbine

and it is only a first failure rate estimation, then higher failure rate. After that it will be developed better in coming studies in which employing other reliability technique such as reliability block diagram (RBD).

- The reliability prediction results at system, sub-system, assembly and sub-assembly have been shown in the Figure 15, Figure 16 and Figure 17.

Value	Result
<i>Failure Rate, Predicted</i>	1866,36
<i>MTBF, Predicted</i>	536
<i>Reliability, Predicted</i>	0,829
<i>Availability</i>	0,98
<i>MTTR</i>	10,77

Table 6. Results Reliability Prediction

ITEM	MTBF[hours]	Failure rate (λ)[millions of hours]
<i>Offshore WT</i>	536	1866,36
<i>Rotor Module</i>	2980	335,61
<i>Drive Train Module</i>	9094	109,96
<i>Nacelle Module</i>	19384	51,58
<i>Structural Module</i>	22299	44,84
<i>Power Module</i>	20998	47,62
<i>Control and Safety System</i>	7948	125,82
<i>Control and Communication</i>	7524	132,9
<i>Condition Monitoring System</i>	114382	8,74
<i>Auxiliary Equipment</i>	1014	985,88
<i>Wind Far System</i>	42781	23,37

Table 7. Results Reliability Prediction on Assemblies

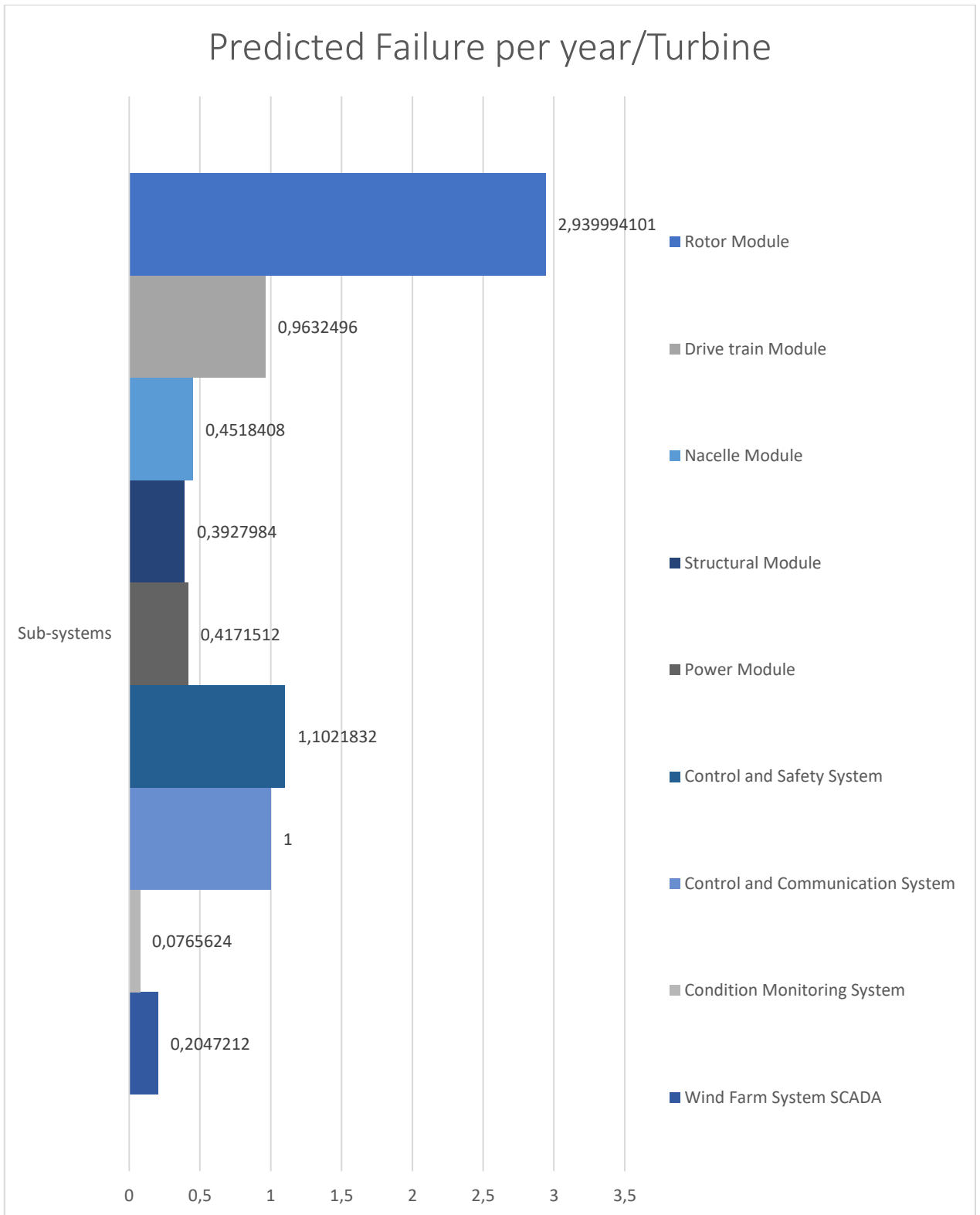

Figure 13. Results Reliability Prediction on sub-systems

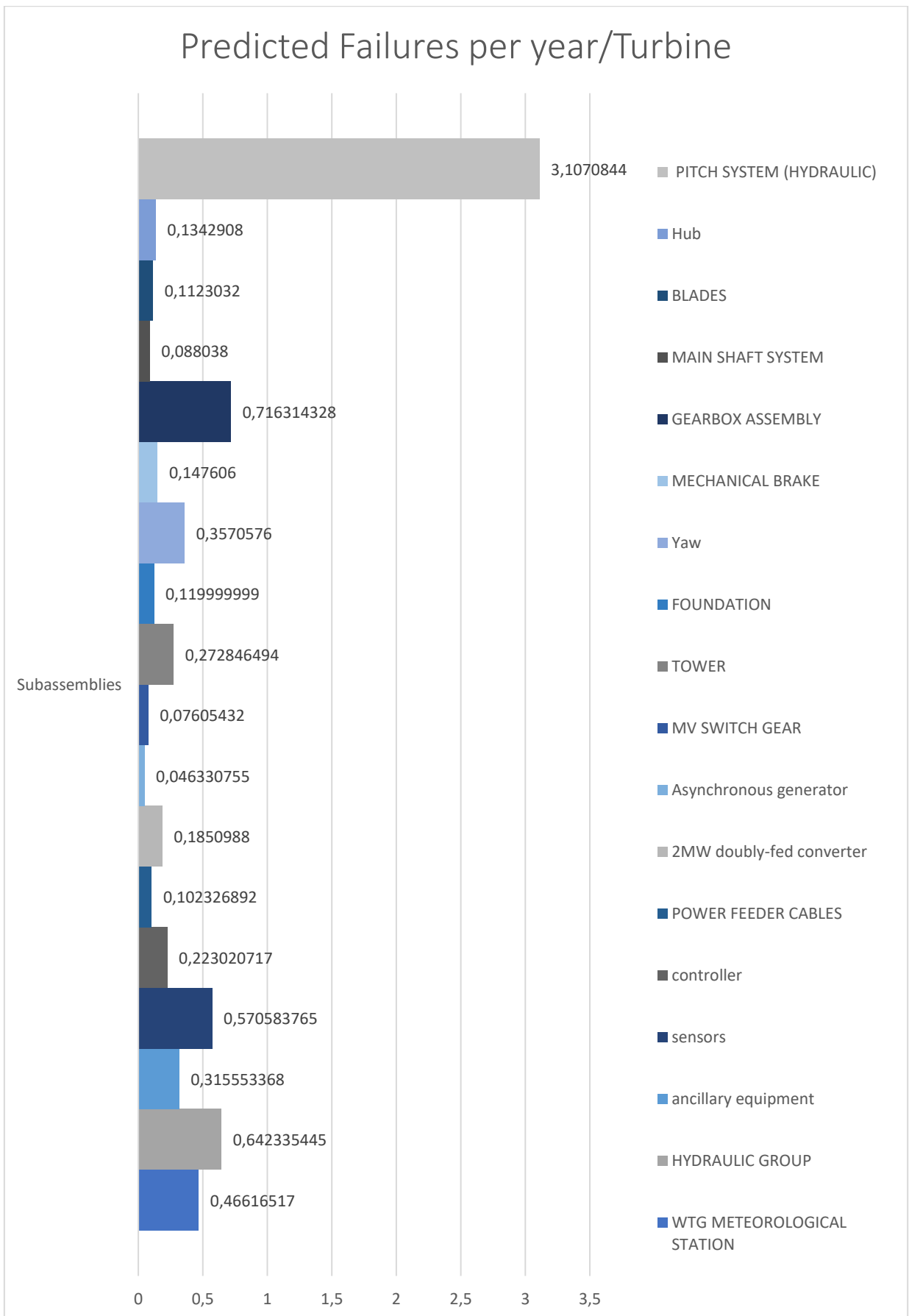

Figure 14. Results Reliability Prediction on Sub-Assemblies

File Name: DTU 10MW OFFSHORE WIND TURBINE
System: DTU-10MW

Failure Rate: 1866,36
MTBF (hrs): 536
Temperature: 30

Description: Reliability Prediction

Environment: NS-Naval Sheltered/NE-Naval Exposed

Name	Part Number	Quantity	Failure Rate	MTBF
WTG	DTU10MW	1	1866.363968	536
ROTOR MODULE	DTU10MW-A	1	335.615765	2,980
PITCH SYSTEM (HYDRAULIC)	DTU10MW-AA	1	295.482819	3,384
HYDRAULIC CYLINDERS	DTU10MW-AAA	3	159.166700	6,283
DISTRIBUTOR BLOCK WITH FILTER	DTU10MW-AAB	1	8.143832	122,792
LEAK OIL CONTAINER	DTU10MW-AAC	1	10.513815	95,113
ACCUMULATORS	DTU10MW-AAD	1	8.086632	123,661
HYDRAULIC CIRCUIT	DTU10MW-AAE	1	91.710291	10,904
PITCH SYSTEM BRACKETS	DTU10MW-AAF	1	2.427091	412,016
ROTATING UNION	DTU10MW-AAG	1	15.434457	64,790
Hub	DTU10MW-AC	1	15.338617	65,195
BLADES	DTU10MW-AD	3	12.825648	77,969
BLADE BEARINGS	DTU10MW-AE	1	2.606810	383,611
EXTENDER	DTU10MW-AN	3	0.229452	4,358,209
SLIPRINGS	DTU10MW-AG	1	9.132420	109,500
DRIVE TRAIN MODULE	DTU10MW-B	1	109.964427	9,094
MAIN SHAFT SYSTEM	DTU10MW-BA	1	10.057574	99,428
Main Shaft	DTU10MW-BAA	1	1.600954	624,627
Rotor main shaft coupling	DTU10MW-BAB	1	7.315067	136,704
Main shaft gear box coupling	DTU10MW-BAC	1	1.141553	876,000
GEARBOX ASSEMBLY	DTU10MW-BB	1	81.771042	12,229
GEARBOX	DTU10MW-BBA	1	81.771042	12,229
LS planetary module	DTU10MW-1	1	8.354624	119,694
LS-I parallel module	DTU10MW-2	1	5.160574	193,777
HS-I parallel module	DTU10MW-3	1	5.588436	178,941
HS parallel module	DTU10MW-4	1	22.031659	45,389
Housing	DTU10MW-5	1	1.642050	608,995
Lubrication system	DTU10MW-6	1	26.621850	37,563
Accessories	DTU10MW-7	1	12.371850	80,829
MECHANICAL BRAKE	DTU10MW-BC	1	16.852000	59,340
DRIVE TRAIN SILENT BLOCKS	DTU10MW-BD	1	0.000000	0
HIGH SPEED SHAFT TRANSMISSION	DTU10MW-BE	1	1.283810	778,931
GENERATOR SILENT BLOCKS	DTU10MW-BF	1	0.000000	0
NACELLE MODULE	DTU10MW-C	1	51.588446	19,384
Yaw	DTU10MW-CA	1	40.766528	24,530
Yaw Drive	DTU10MW-CA.D	1	16.974887	58,911
Yaw Brake	DTU10MW-CA.B	1	23.791641	42,032
Nacelle cover	DTU10MW-CD	1	9.531963	104,910
Nacelle Body Structure	DTU10MW-CE	1	0.148402	6,738,462
Nacelle sensors	DTU10MW-CF	1	1.141553	876,000
STRUCTURAL MODULE	DTU10MW-D	1	44.845490	22,299
FOUNDATION	DTU10MW-DA	1	13.698630	73,000
Connection Elements	DTU10MW-DA.A	1	2.283105	438,000
Transition piece	DTU10MW-DA.B	1	7.415525	134,852
Pile	DTU10MW-DA.D	1	2.283105	438,000
TOWER	DTU10MW-DB	1	31.146860	32,106
Sections	DTU10MW-DB.A	1	12.555538	79,646
Access equipment	DTU10MW-DB.B	1	6.437487	155,340

Figure 15. Reliability Prediction Results Part 1

File Name: DTU 10MW OFFSHORE WIND TURBINE
System: DTU-10MW

Failure Rate: 1866,36
MTBF (hrs): 536
Temperature: 30

Description: Reliability Prediction

Environment: NS-Naval Sheltered/NE-Naval Exposed

Name	Part Number	Quantity	Failure Rate	MTBF
Tower Platform	DTU10MW-DB.C	1	9.132420	109,500
Tower Sensors	DTU10MW-DB.D	1	3.010000	332,226
Cable supports	DTU10MW-DB.E	1	0.011416	87,600,000
POWER MODULE	DTU10MW-E	1	47.622500	20,998
MV SWITCH GEAR	DTU10MW-EA	1	8.682000	115,181
Asynchronous generator	DTU10MW-EB	1	5.288899	189,075
STATOR	DTU10MW-EBA	1	1.258973	794,298
ROTOR	DTU10MW-EBB	1	1.865282	536,112
BEARINGS	DTU10MW-EBC	1	0.481262	2,077,870
Cooling	DTU10MW-EBD	1	1.081932	924,273
AUXILIARY	DTU10MW-EBE	1	0.601450	1,662,649
2MW doubly-fed converter	DTU10MW-EC	1	21.130900	47,324
Crowbar	DTU10MW-ECA	1	3.046000	328,299
Charging circuit	DTU10MW-ECB	1	1.133000	882,613
Line filter assembly	DTU10MW-ECC	1	2.677000	373,552
Auxiliary power supply	DTU10MW-ECD	1	0.051500	19,417,476
Converter Control Unit	DTU10MW-ECE	1	7.897000	126,630
Grid-side converter	DTU10MW-ECF	1	2.020000	495,050
Generator-side converter	DTU10MW-ECG	1	3.738400	267,494
Cabinet heating system	DTU10MW-ECH	1	0.568000	1,760,563
TRANSFORMER	DTU10MW-ED	1	0.839549	1,191,116
POWER FEEDER CABLES	DTU10MW-EE	1	11.681152	85,608
CONTROL & SAFETY SYSTEM GH	DTU10MW-GH	1	125.821453	7,948
controller	DTU10MW-FA	1	25.458986	39,279
Safety chain	DTU10MW-FB	1	4.530982	220,703
Communication system	DTU10MW-FC	1	23.076756	43,334
sensors	DTU10MW-FD	1	46.751433	21,390
ancillary equipment	DTU10MW-FE	1	26.003296	38,457
CONTROL & COMMUNICATION SYSTEM	DTU10MW-GA	1	132.900609	7,524
CONTROL SYSTEM	DTU10MW-FA	1	103.901277	9,625
HUMAN & OPERATIONAL SAFETY DEVICES	DTU10MW-FB	1	28.999332	34,484
INSTRUMENTATION	DTU10MW-FC	1	0.000000	0
CONDITION MONITORING SYSTEM	DTU10MW-G	1	8.742623	114,382
DATA LOGGER	CMS-01	1	0.671710	1,488,738
PROTOCOL ADAPTER RJ45-RS232	CMS-02	1	0.251890	3,969,987
VIBRATIONS SENSORS	CMS-03	5	4.712373	212,207
RJ45 CABLE	CMS-04	1	3.106650	321,890
AUXILIARY EQUIPMENT	DTU10MW-H	1	985.887816	1,014
GROUND	DTU10MW-HB	1	13.560132	73,746
HYDRAULIC GROUP	DTU10MW-HF	1	73.325964	13,638
TOP	DTU10MW-HA	1	316.211587	3,162
HUB CABINET	DTU10MW-HC	1	84.159833	11,882
UPS CABINET	DTU10MW-HD	1	6.081072	164,445
ELECTRICAL PROTECTION & SAFETY DEVICES	DTU10MW-HE	1	16.479149	60,683
COOLING SYSTEM	DTU10MW-HG	1	116.717363	8,568
BEACON	DTU10MW-HK	1	11.980000	83,472

Figure 16. Reliability Prediction Results Part 2

File Name: DTU 10MW OFFSHORE WIND TURBINE
System: DTU-10MW

Failure Rate: 1866,36
MTBF (hrs): 536
Temperature: 30

Description: Reliability Prediction

Environment: NS-Naval Sheltered/NE-Naval Exposed

Name	Part Number	Quantity	Failure Rate	MTBF
ELEVATION SYSTEM	DTU10MW-HL	1	79.330000	12,606
LIFELINE	DTU10MW-HM	1	24.470000	40,866
LIGHTING	DTU10MW-HH	1	13.080000	76,453
ELECTRICAL AUXILIARY CABLING	DTU10MW-HO	1	0.420000	2,380,952
FIREFIGHTING SYSTEM	DTU10M-HQ	1	14.439805	69,253
AUXILIARY BOXES	DTU10MW-HR	1	17.942830	55,733
LIGHTNING PROTECTION SYSTEM	DTU10MW-HN	1	8.073421	123,863
GROUNDING	DTU10MW-HI	1	105.431460	9,485
SERVICE CRANE	DTU10MW-HJ	1	30.970000	32,289
WTG METEOROLOGICAL STATION	DTU10MW-HP	1	53.215202	18,792
WIND FARM SYSTEM	DTU10MW-IB	1	23.374840	42,781
Scada Server System - server #1	DTU10MW-IBA	1	7.729900	129,368
SCADA Data Base Server – server #2	DTU10MW-IBB	1	6.984140	143,182
SCADA Server Rack – WF infrastructure communication	DTU10MW-IBC	1	0.010000	100,000,000
SCADA Server Rack – WF external communication	DTU10MW-IBD	1	0.500000	2,000,000
SCADA Server Rack	DTU10MW-IBE	1	7.779300	128,546
SCADA Server UPS	DTU10MW-IBF	1	0.371500	2,691,790

Figure 17. Reliability Prediction Results Part 3

4 Reliability Block Diagram (RBD)

4.1 Definition and Assumptions

A Reliability Block Diagram (RBD) is a visual representation of the parts of the system, through blocks (representing items) linked together (Figure 19). An RBD also shows how various parts are connected logically to fulfil the system requirements. Since reliability predictions assume that all components in a system are in series, they cannot be used to analyse a system with redundant components. RBDs are used to evaluate the reliability of systems that are complex in their configurations. RBDs also provide an efficient and effective way to compare various configurations to identify the best overall system design. An example of a RBD for the OWT that presents redundancies is depicted in Figure 18. The pitch system RBD shows how the main line is connected in standby configuration with the emergency line. A functional reliability model is created in order to evaluate the real configuration on the typical 10 MW wind turbine, and shown in Figure 20.

The goal of the Reliability Block Diagram is to determine the reliability and maintainability metrics—such as Reliability, Availability, Failure rate and MTTR (mean time to repair)—for a complete system. The elements which are necessary for the required function are connected in series, while elements which can fail with no effect on the required function are connected with redundancies. There are three types of redundancies: parallel, load sharing and standby.

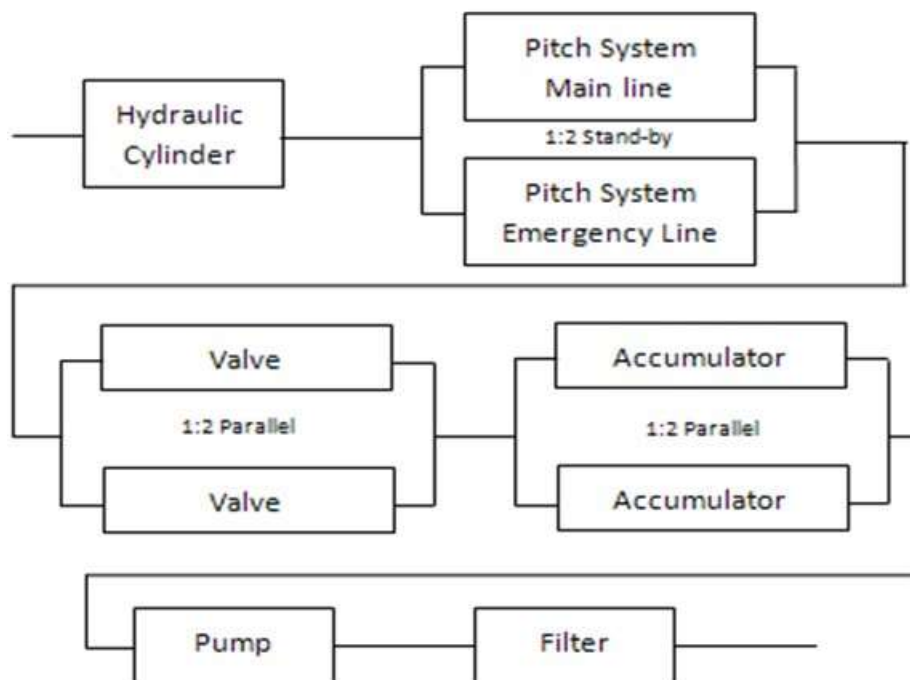

Figure 18. Pitch system RBD

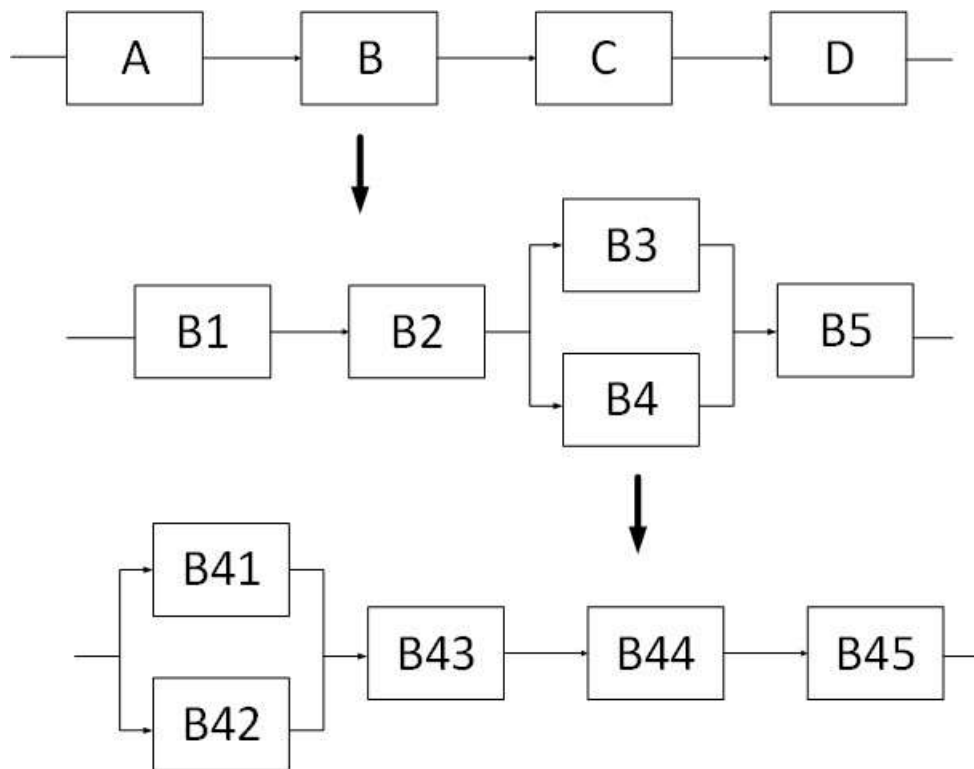

Figure 19. *Development of a RBD within a system*

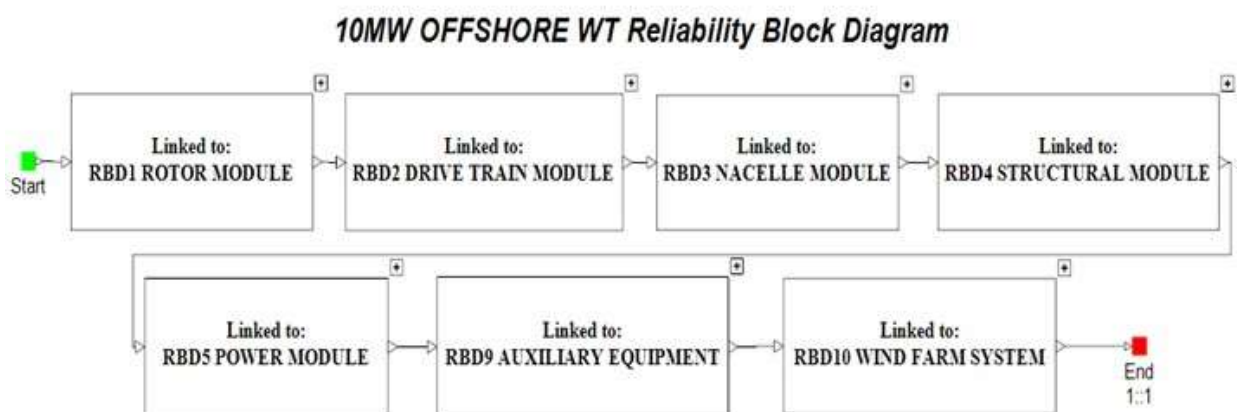

Figure 20. *Main RBD of the Offshore Wind Turbine*

4.2 General Concepts

RBD often takes the form of a logic model for analysing, allocating and achieving RAM parameters.

Reliability modelling has numerous benefits in addition to reliability prediction, because using reliability modelling can:

- Improve understanding of the equipment.
- Effectively model redundancy (functional reliability model) where will be known critical subsystems, components and parts as well as their interactions between items.
- Identify problematic systems, subsystems or parts.

- Determine if the design meets requirements.
- Identify the best design alternative in order to improve reliability.
- Determine the impact of proposed design changes.

RBD must be carried out through several steps for achieving the best results:

1. Specify the functions of the system and the operating states by reference to the data assembled during System Definition.
2. Specify the minimum requirements for the system to operate successfully in terms of the functions of the system.
3. Draw a system RBD in terms of the system functions.
4. Specify the sub-systems that are required to perform the system functions.
5. Draw a system RBD in terms of the sub-systems and simplify as necessary.

Each block could be linked to another RBD as the Figure 19 shows. The modelling of the wind turbine is complicated due to a lot of assemblies, sub-assemblies and components (almost one thousand components has the reference turbine). Therefore, a complex system had been done with blocks linked together at every level as is showed in the following Figure 20.

Each block is characterized by:

- The general information (name, part number, reference designator and description).
- The failure rate (from prediction) and the failure distribution.
- The total number of units present in the system.
- Redundancy type.
- The corrective maintenance or repair information.

The elements which are necessary for the required function are then connected **in series**, while elements which can fail with no effect on the required function (redundancy) are connected with **redundancy**.

RBD should be made with redundant configurations, if it is required to perform the required function.

4.3 Redundancies

The Offshore wind turbine has to operate for longer periods without interruption, therefore the better approach to achieve higher reliability and availability is to reduce the failure rate using redundancies. Redundancies are needed in order to carry out the RBD analysis of complicate structure as wind turbines. Redundancy is the existence of more than one means for performing a required function in an item.

There are 4 types of redundancies:

- **Series**: is depicted in the following Figure 21 in which the items are represented in series and the failure rate is calculated with the sum of every failure rate of all items like was done on reliability prediction analysis. The reliability function is calculated by:

$$R_S = \prod_{i=1}^n R_i \quad 4.1$$

$$\lambda_S(t) = \lambda_1(t) + \dots + \lambda_n(t) \quad 4.2$$



Figure 21. Items in series redundancy

- Parallel: a parallel model consists of n elements in active redundancy, of which k are necessary to perform the required function such as k -out-of- n . Let us consider first the case of an active 1-out-of-2 redundancy as given in Figure 22. The required function is fulfilled if at least one of the elements A_1 or A_2 works without failures in the interval $(0, t]$. Assuming that the elements A_1 and A_2 work or fail independently of each other, in which the reliability function is:

$$R_1(t) = R_2(t) = e^{-\lambda t} \quad 4.3$$

$$\text{Parallel Redundancy} = R_S(t) = R_1(t) + R_2(t) - R_1(t) \cdot R_2(t) \quad 4.4$$

$$R_S(t) = 2e^{-\lambda t} - e^{-2\lambda t} \quad 4.5$$

If reliability function wants to be expressed by Mean Time to Failure(MTTF) using the following equation already explained before:

$$MTTF = E[\tau] = \int_0^{\infty} R(t) dt \quad 4.6$$

$$\lambda_S(t) = 2\lambda \frac{1 - e^{-\lambda t}}{2 - e^{-\lambda t}} \quad 4.7$$

$$MTTF = \frac{2}{\lambda} - \frac{1}{2\lambda} = \frac{3}{2\lambda} \quad 4.8$$

The Figure 22 is a series-parallel structure that can be investigated through successive use of the results for series and parallel models. Then the reliability function of the whole Figure 22 is:

$$R_S = (R_{A1} + R_{A2} - R_{A1} \cdot R_{A2}) \cdot R_B = (2e^{-\lambda t} - e^{-2\lambda t}) \cdot e^{-\lambda t} \\ = e^{-(\lambda_{A1} + \lambda_B)t} + e^{-(\lambda_{A2} + \lambda_B)t} - e^{-(\lambda_{A1} + \lambda_{A2} + \lambda_B)t} \quad 4.9$$

$$MTTF = \frac{1}{\lambda_{A1} + \lambda_B} + \frac{1}{\lambda_{A2} + \lambda_B} - \frac{1}{\lambda_{A1} + \lambda_{A2} + \lambda_B} \quad 4.10$$

The reliability of an m/n system with n independent components in which all the unit reliabilities are equal, is the binomial reliability function:

$$R_{SYS} = 1 - \sum_{i=0}^{m-1} \binom{n}{i} R^i (1-R)^{n-i} \quad 4.11$$

- **Load Sharing:** is achieved when a load is shared between several items, then the load is sharing with an average between them.
- **Standby:** it is similar to parallel model but in this case only a component is working and another one is waiting in standby. When the working component fail, the second component starts to work. So, a unit doesn't operate continuously but is only switched on when the primary unit fails.

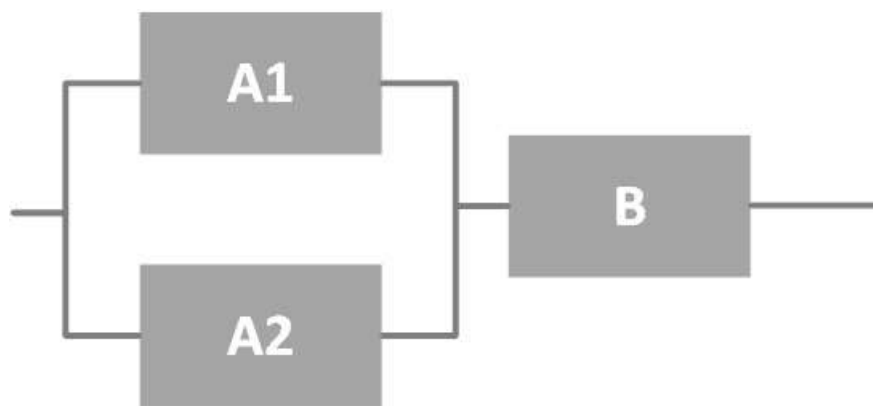

Figure 22. *Items in parallel, load sharing or standby redundancy*

Every result from reliability prediction and reliability block diagram (RBD) has been calculated by PTC Windchill Quality Solutions, the software that Relex Italia s.r.l. is using to carry out RAMS (reliability, availability, maintainability and safety) analysis.

4.4 Availability of Repairable Systems

The Availability is the probability that the system is operating satisfactorily at any point in time when used under stated conditions; here, the time considered includes operating time, active repair time, administrative time and logistic time. Through this parameter, one can calculate the inherent availability, in which the proportion of the total time that the item is available is the steady-state availability. Therefore, the availability of an item is a function of its failure rate λ and of its repair or replacement rate λ . The difference between repairable and non-repairable system is illustrated graphically in Figure 23. For a simple unit with a constant failure rate and a constant mean repair rate, λ is shown as Eq. (4.12):

$$\mu = \frac{1}{\text{MTTR}} \quad 4.12$$

Then, Eq. (4.13) can be derived to calculate the steady-state availability:

$$A = \frac{MTBF}{MTBF + MTTR} = \frac{\mu}{\lambda + \mu} \tag{4.13}$$

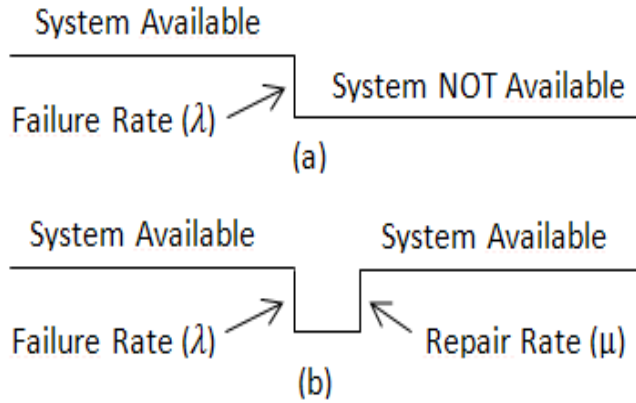

Figure 23. *Non-reparable system and b) Repairable system*

4.5 Reliability Block Diagram Results

RBD results for our study are shown in Figure 24, Figure 25, Table 8, Figure 26, Figure 27, Figure 28 and Figure 29. From Figure 25 it can be seen that the MTBF is equal to 3723.37 h (2.37 failures per year). According to theory, the value of MTBF is the time at which the reliability value is 0.37. The inherent availability is calculated with a year mission time (8760 h), and at that time the value of inherent availability is about 99 %.

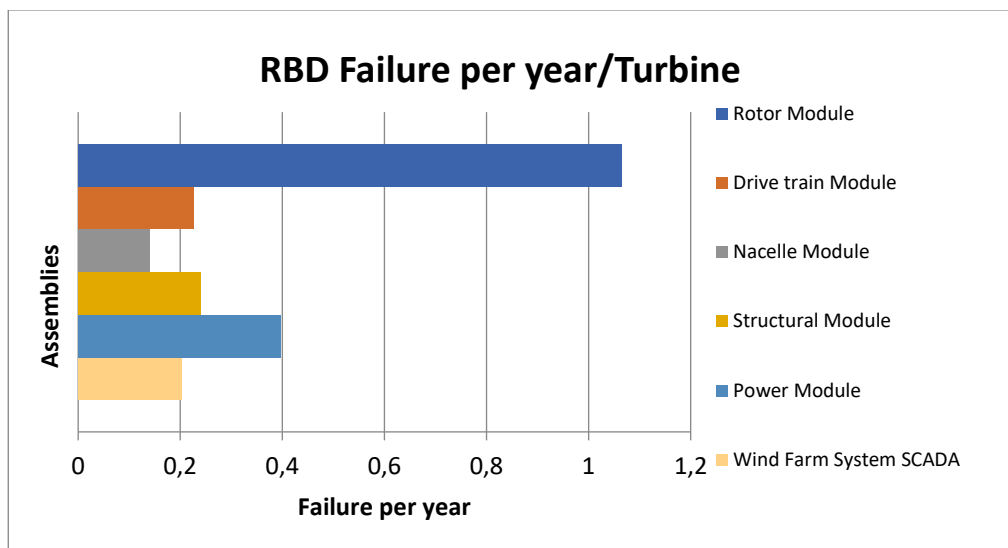

Figure 24. *Results RBD on sub-systems*

Reliability(t) 1 year operation 10MW Offshore Wind Turbine

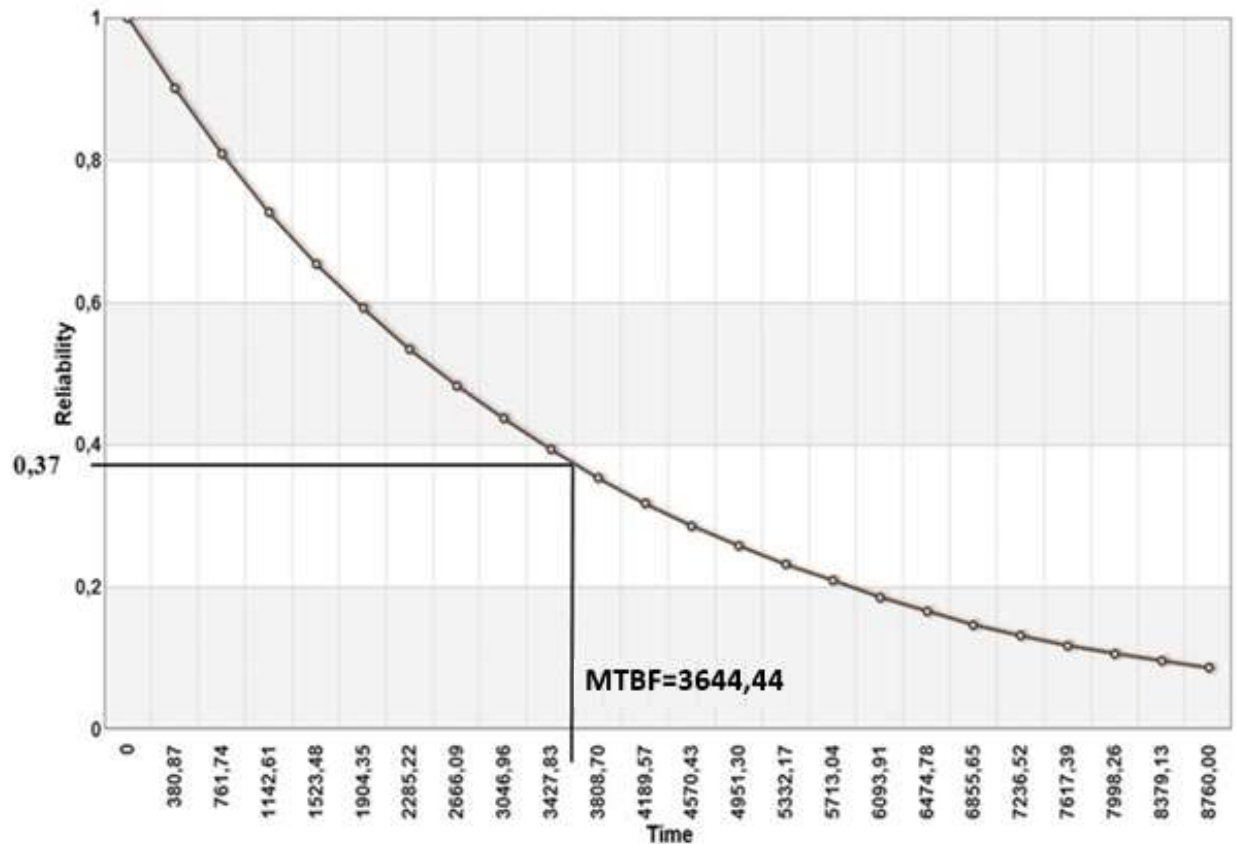

Figure 25. Reliability through time in a year operation

ITEM	MTBF[hours]	Failure Rate (λ)[million of hours]
Offshore WT	3644,44	274,39
Rotor Module	8227,74	121,54
Drive Train Module	38580,24	25,92
Nacelle Module	62500	16,00
Structural Module	36616,62	27,31
Power Module	22040,99	45,37
Control and Safety System	9102,49	109,86
Control and Communication System	8631,85	115,85
Condition Monitoring System	201207,24	4,97
Auxiliary Equipment	71530,75	13,98
Wind Farm System	42789,90	23,37

Table 8. Results Reliability Block Diagram

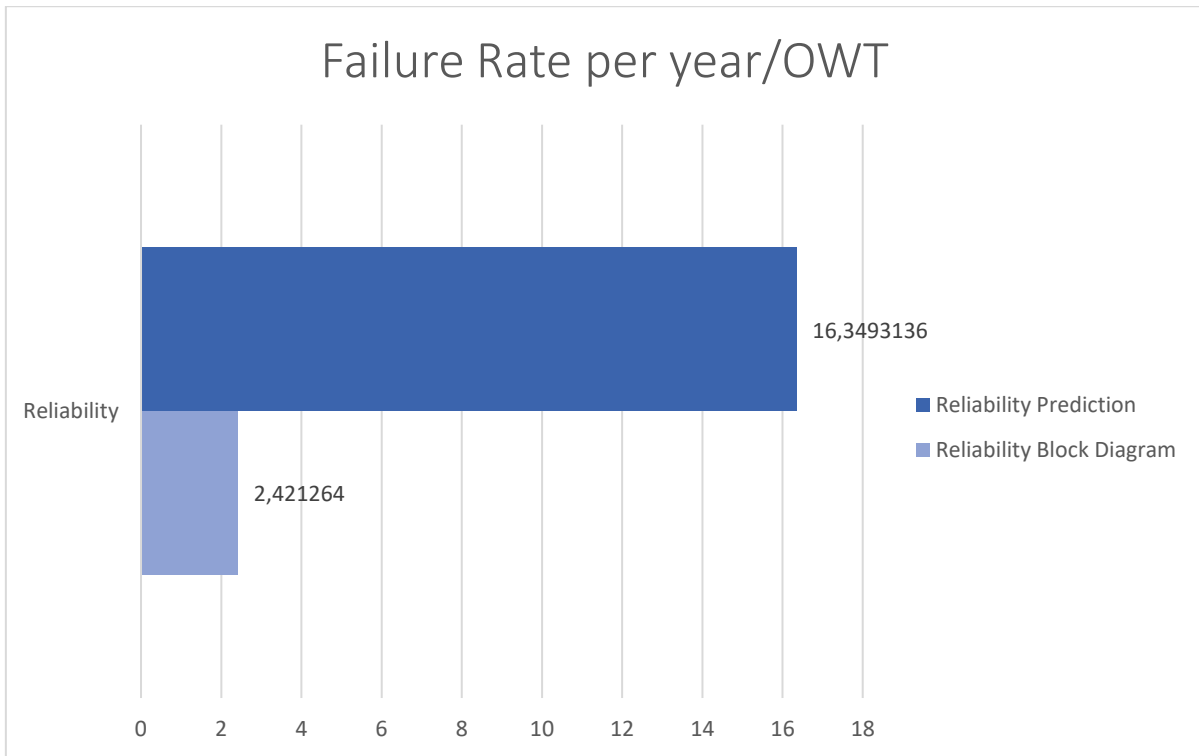

Figure 26. Comparative results between RBD and Reliability Prediction

Reliability Method on OWT	MTBF [hours]	Failure Rate (λ) [million of hours]
Reliability Prediction	536	1866,36
RBD	3644,44	274,39

Figure 27. Comparative results between RBD and Reliability Prediction

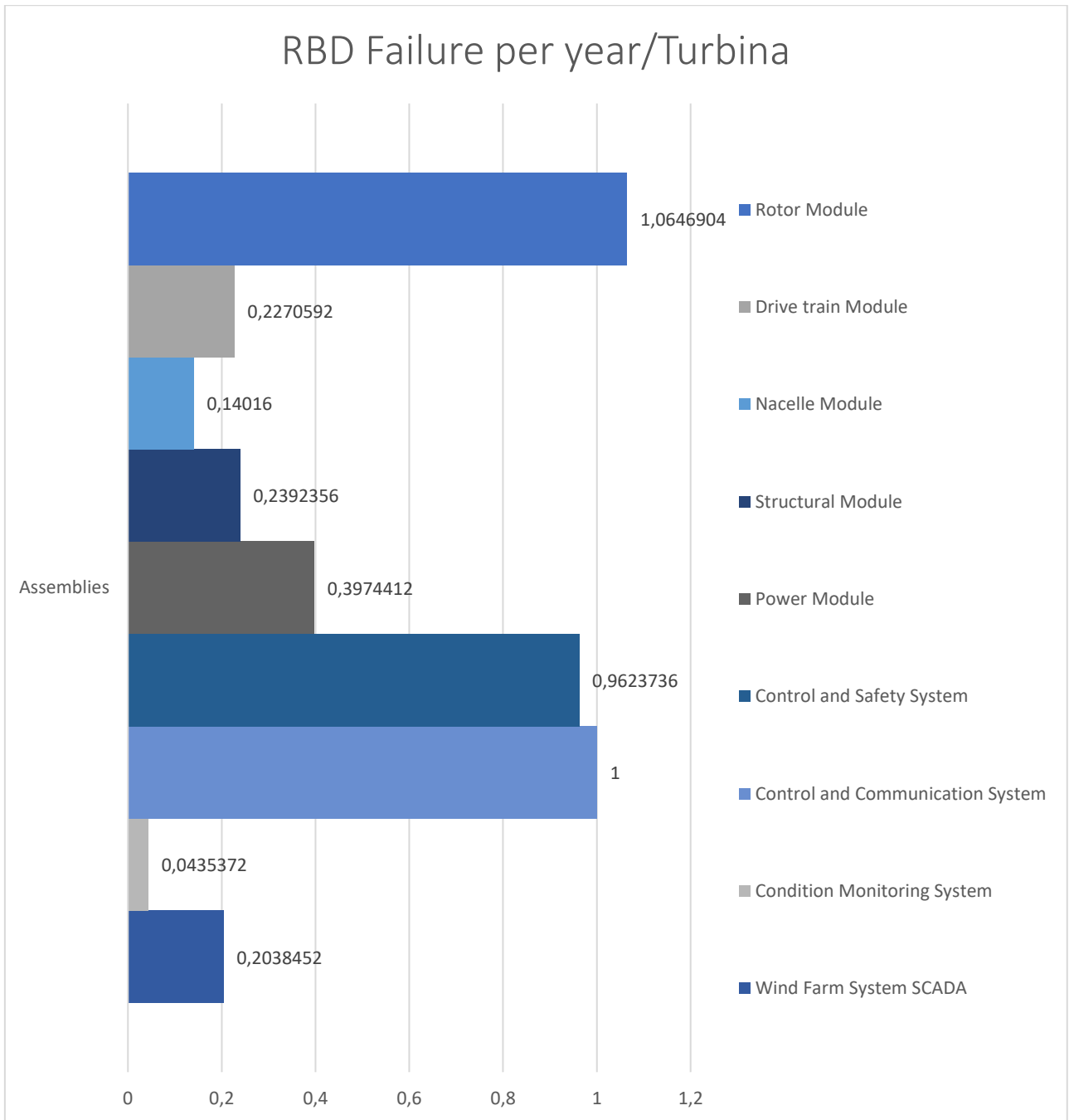

Figure 28. Results RBD on Assemblies

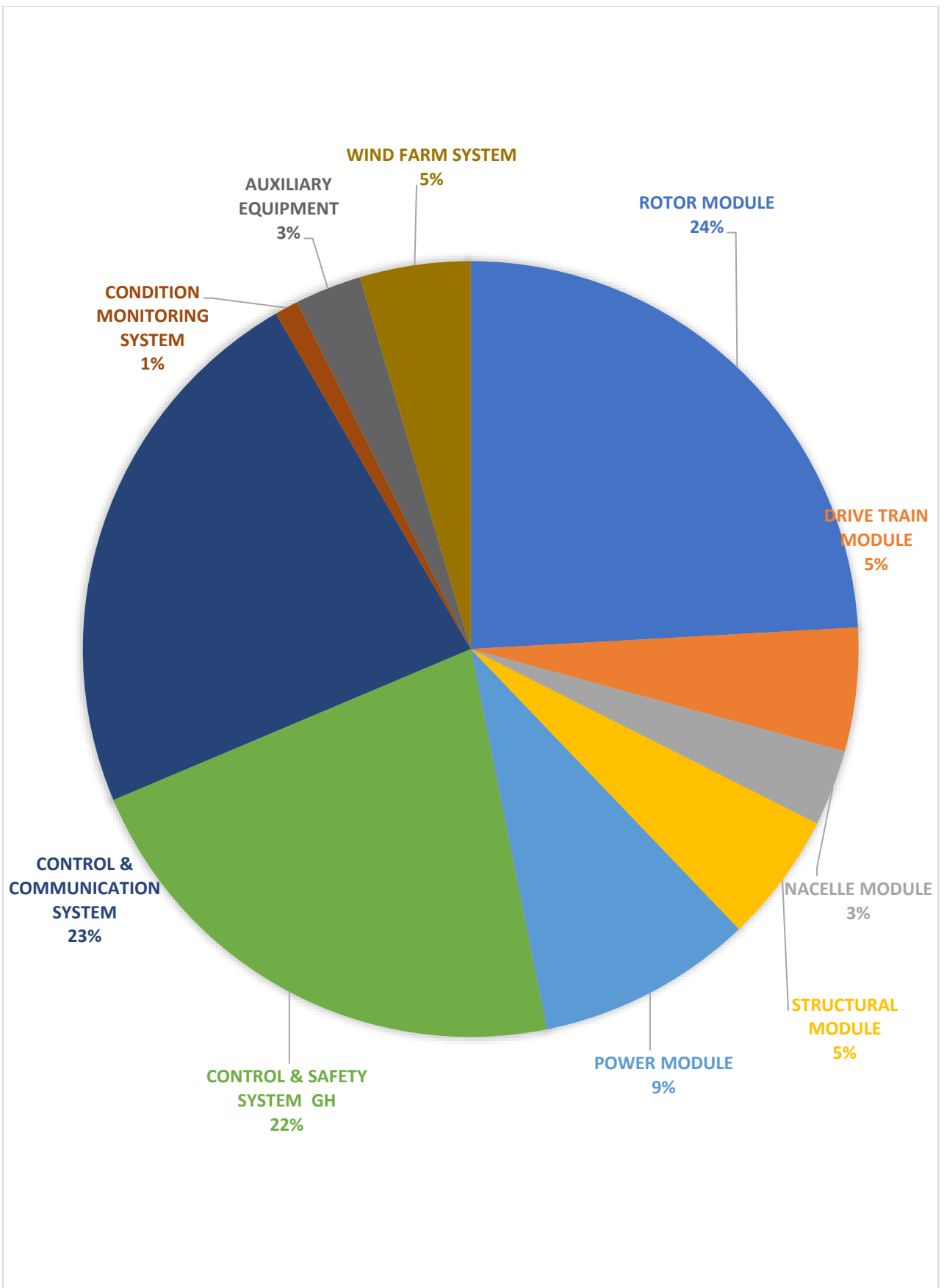

Figure 29. Distribution of failures per year/turbine

4.6 Analysis of RBD results

Reliability block diagram results have been published in Figure 31. The offshore wind turbine is represented by block in the Figure 32. How the results show, the offshore wind turbine is expected that appears a failure at the fifth month. The availability has reached to 99% in a year (great achievement) and it could be higher if the MTTR is more accurate. Under a great condition monitoring system and a good RCM plan (maintenance about the fifth month), the offshore wind turbine will achieve an excellent reliability. The Figure 30 shows the main hierarchy 10MW offshore wind turbine selected parts for the RBD.

- As expected, the results show a great difference between the reliability prediction and the reliability block diagram because the reliability prediction is made in order to know a first estimation of failure rate and after that RBD simulates the real operating condition of the offshore wind turbine. Reliability prediction results points out a failure rate equal to 16.3 failures per year against the RBD results which points a failure rate equal to 2.4 per year. The reliability prediction results are high and can not sustainable. Instead, the RBD present a failure rate more real because it is based on real conditions of the wind turbine. The redundancies help to calculate a real failure rate. It means that the failure rate of the wind turbine could also decrease based on the design. In cases for items with high failure rate may be good way to design the item another time into the wind turbine through more component in stand-by instead of an item alone. It decreases the failure rate. It impacts on the installation wind turbine cost but it is covered with lower failure rate. Series, parallel, load sharing and standby redundancies can be played in order to change the design of the wind turbine, looking a decrease in the failure rate. Moreover, wind turbine items which are working for a little time, can be reduced the failure rate due.
- The Figure 25 shows the reliability through the time in an operational year. Based on the failure rate equal to 2.4 failures per year, the offshore wind turbine is reliable until 3644.44 hours when the first failure arrives and the offshore wind turbine becomes unreliable.
- As could be expected, power module has lower failure rate than rotor module, control communication and safety system.
- The failure rate of the main assemblies such as Drive Train Module, Rotor Module and nacelle module has decreased a lot against the reliability prediction and therefore the high decrease of the offshore wind turbine failure rate.
- As can be seen in the Figure 32, Control and Safety System and Control and Communication System are not taken into account due to these assemblies are not necessary for the required function of the turbine. If these systems have a failure, it can be repaired into the next maintenance task without no effect into the normal operation of the offshore wind turbine.
- Also, through a good FMECA results the system configuration could be improved in order to obtain better RBD results. FMECA (Failure Mode Effects and Criticality Analysis) is a reliability analysis method which identifies all potential failure modes, the end effects of each potential failure mode and analyses the criticality on the system of each failure effect, hence analyzing

and studying every component in order to understand the function on the wind turbine. It means that in order to develop a great RBD, a FMECA must be carrying out before because the most criticality components on the wind turbine will already be known. Therefore, after FMECA, the elements which are necessary for the required function and elements which can fail without effect are known. Through FMECA has been known which components could operate in redundancies.

- The reliability field isn't a process that could be developed along the fix time. Instead reliability analysis must be developed and shortly after update each time. Then reliability is a process that has to be carried out all the time and must be improved the time. Therefore, when the maintenance plan will be done, the results will be improved and will be taken under consideration the logistic time, schedule maintenance time and the right reliability centered maintenance (RCM).

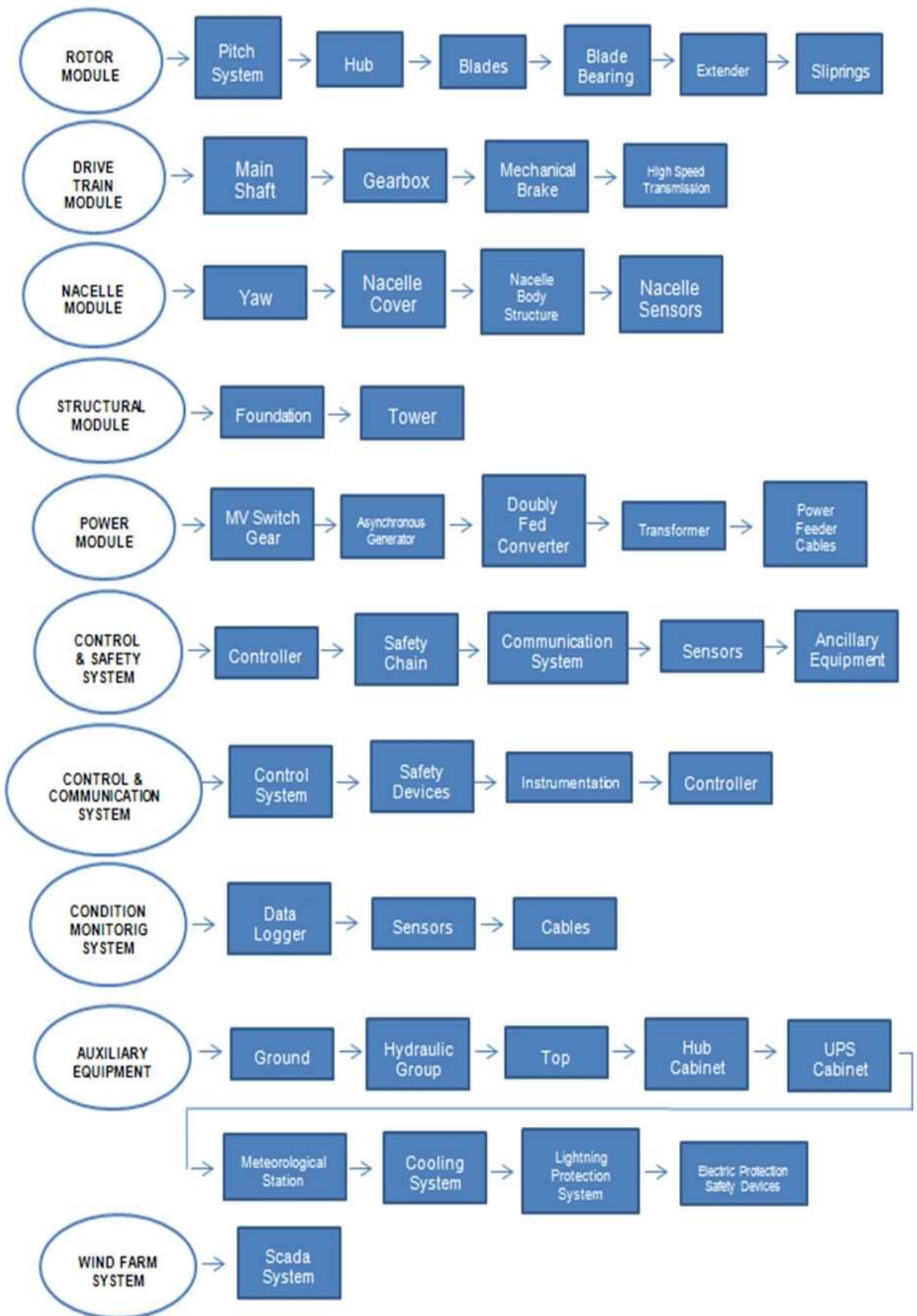

Figure 30. Whole Hierarchy Offshore DTU 10MW Wind Turbine

File Name: RBD.rfp
 Identifier: RBD 10MW OWT
 Calc Method: Monte Carlo Simulation
 MTBF (hrs): 3,723
 MTTF (hrs): 3,678

Results at Time (hrs): 8760
 Reliability: 0.091979
 Availability: 0.994195
 No. of Failures: 2.35
 Total Downtime: 50.20

Time	Reliability	Unreliability	Availability	Unavailabilit	Failure Rate	Number of Failures	Total Downtime
0	1.000000	0.000000	1.000000	0.000000	N/A	0.000000	0.000000
380.87	0.902349	0.097651	0.994491	0.005509	269.787097	0.102285	1.693075
761.74	0.814225	0.185775	0.994285	0.005715	269.817984	0.204343	3.849321
1142.61	0.734327	0.265673	0.994229	0.005771	271.173395	0.306754	6.052147
1523.48	0.662332	0.337668	0.994196	0.005804	270.926462	0.409096	8.258439
1904.35	0.597448	0.402552	0.994215	0.005785	270.694697	0.511322	10.465484
2285.22	0.538872	0.461128	0.994230	0.005770	270.932409	0.613472	12.667865
2666.09	0.485899	0.514101	0.994229	0.005771	271.685467	0.715891	14.876023
3046.96	0.438113	0.561887	0.994232	0.005768	271.808168	0.818175	17.072621
3427.83	0.395033	0.604967	0.994210	0.005790	271.770952	0.920542	19.278692
3808.7	0.356095	0.643905	0.994220	0.005780	272.458243	1.022783	21.484128
4189.57	0.321019	0.678981	0.994263	0.005737	272.263780	1.124985	23.693577
4570.43	0.289406	0.710594	0.994204	0.005796	272.191487	1.227371	25.897938
4951.3	0.260803	0.739197	0.994235	0.005765	273.228570	1.329768	28.103129
5332.17	0.235089	0.764911	0.994172	0.005828	272.544909	1.431969	30.308167
5713.04	0.211857	0.788143	0.994213	0.005787	273.189527	1.534365	32.519766
6093.91	0.190867	0.809133	0.994168	0.005832	273.935032	1.636737	34.728128
6474.78	0.171978	0.828022	0.994218	0.005782	273.621571	1.739089	36.939094
6855.65	0.154965	0.845035	0.994205	0.005795	273.495672	1.841380	39.141847
7236.52	0.139606	0.860394	0.994232	0.005768	274.042559	1.943682	41.348680
7617.39	0.125813	0.874187	0.994174	0.005826	273.137803	2.045966	43.560319
7998.26	0.113379	0.886621	0.994216	0.005784	273.214233	2.148026	45.775963
8379.13	0.102112	0.897888	0.994182	0.005818	274.813228	2.250318	47.987098
8760	0.091979	0.908021	0.994195	0.005805	274.390583	2.352702	50.200613

Figure 31. RBD Offshore Wind Turbine

DTU 10MW OFFSHORE WT Reliability Block Diagram

Figure 32. RBD Offshore Wind Turbine

5 FMECA approach for an Off-Shore Wind Turbine

5.1 FMECA definition

A Failure Mode, Effects and Criticality Analysis (FMECA) is one of the most used analysis tools in the engineering field for developing designs, processes and services. To develop a FMECA, potential failure modes are analysed to determine their effects all along the system, and classified according to their severity (FMEA) and probability of occurrence (FMECA).

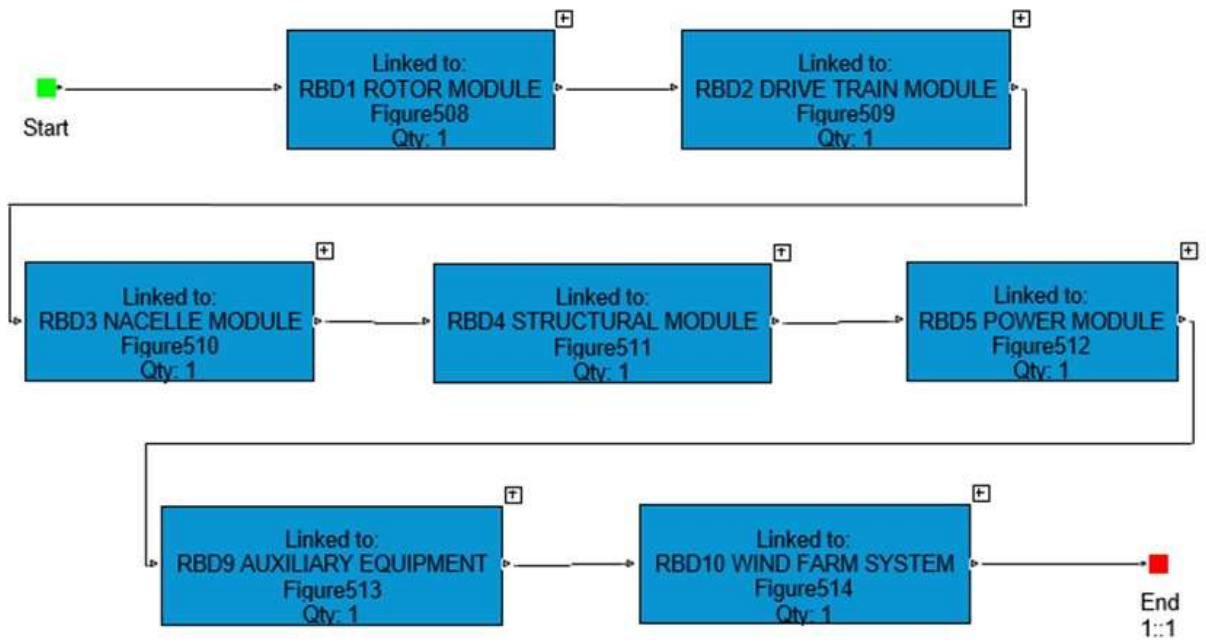
5.2 Objectives

The main target of this analysis is to identify the weakest parts of the OWT, understand their failure modes and the associated effects, and then improve their availability by introducing possible redundancies or design changes, and updating the preventive maintenance. Other objectives that are possible to achieve through this analysis are:

- Anticipate the most important problems.
- Prevent failures from occurring.
- Minimize the failure consequences as cost effectively as possible.
- Give technical information to maintenance personnel about failures that might come out during system life.
- Compare results with previous maintenance reports and update the analysis.
- Provide necessary information to create a cost/benefit analysis.
- Provide those modes that need preventive maintenance in a risk priority order.

5.3 Method

A FMECA is a bottom up approach analysis by which the system design and performance are studied. With this analysis, the potential failure modes are defined, as well as the occurrence and severity of each failure effect associated to them. The analysis can be done in two ways: component level (referred as component FMEA) or functional level (referred as functional FMEA). A component FMECA has been chosen based on the tasks 101 and 102 (Table 9) of the military standard MILSTD-1629A from the Department of Defence of USA [72].

<i>Task</i>	<i>Description</i>
Task 101	Failure Mode and Effects Analysis. The purpose of the Failure Mode and Effects Analysis (FMEA) is to study the results or effects of item failure on system operation and to classify each potential failure according to its severity.
Task 102	Criticality Analysis. The purpose of the Criticality Analysis (CA) is to rank each potential failure mode identified in the FMEA according to the combined influence of severity classification and its probability of occurrence.

Table 9. FMECA MIL-STD-1629 tasks

5.4 Approach

A FMECA can be initiated at any system level but due to the complexity, huge number of components and the lack of data, a proper level of indenture of our OWT has been chosen: the FMEA has been performed starting from the component level, while the FMECA starts from the line replaceable unit (LRU) level. A bottom-up approach is used, noting the failure modes of the lowest level items of the system and then moving up the hierarchy and noting the effect of the failure to the end item (the OWT itself). The Figure 33 illustrates the distribution mentioned before.

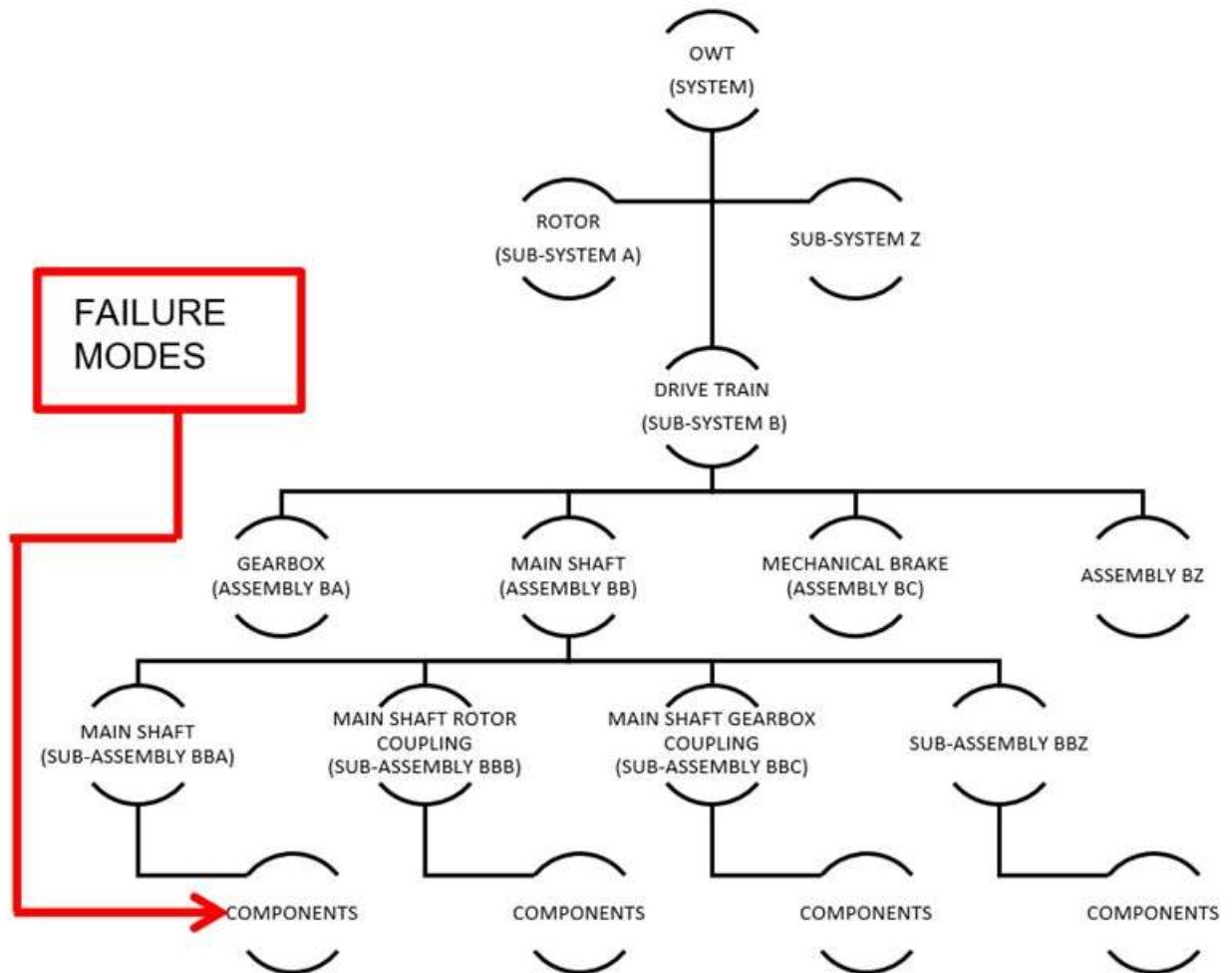

Figure 33. Example of the hierarchy structure used to perform the FMECA

5.5 Criticality

A criticality analysis completes the FMEA by using two parameters: occurrence and severity. With these parameters, the risky parts of the systems are identified. *Calculating* criticality numbers gives us the possibility to define the criticality of each item and its associated failure modes from a quantitative point of view; however, this method is only used when enough data is available. The mode criticality number “C_m” and the item criticality number “C_r” (see Table 10), can be calculated according to definitions in MIL-HDBK-1629 (DoD 1980).

<i>Criticality number</i>	<i>Description</i>
C _m	The portion of the “C _r ” number due to one of its failure modes under a particular severity classification.
C _r	Number of system failures of a specific type expected due to the item’s failure modes.

Table 10. *Criticality numbers description from “MIL-HDBK-1629”*

These numbers are defined using Eqs. (5.1) and (5.2):

$$C_m = \alpha * \beta * \lambda_p * t \quad 5.1$$

$$C_r = \sum_n^j (C_m)_n \text{ for } n = 1, 2 \dots j \quad 5.2$$

Where:

- C_r= Criticality number for the item
- C_m= Criticality number for a failure mode under a particular severity classification.
- α= Failure mode ratio. The probability, expressed as a decimal fraction, that the part or item will fail in the identified mode.
- λ_p= Part failure rate.
- β= Conditional probability of mission loss given that the failure mode has occurred. Table 11 defines β values.
- t= Mission time.
- n= The failure modes in the items that fall under a particular severity classification.
- j= Last failure mode in the item under the severity classification.

<i>β value</i>	<i>Failure effect</i>
1	Actual loss
1 to 0.1	Probable loss
0.1 to 0	Possible loss
0	No effect

Table 11. *β classification from MIL-HDBK-1629*

Alternatively, a qualitative method can be used, which allows us to represent the criticality results using a Risk Matrix. The matrix is constructed by inserting the total number of OWT failure modes in the matrix areas representing the severity classification and the frequency level assigned. The frequency is calculated as the ratio between failure mode probability of occurrence in a certain time interval, and the overall system probability of occurrence in the same time interval, as Eq. (5.3):

$$f = \frac{\lambda_p * \alpha * t}{\lambda_s * t} = \frac{\lambda_p * \alpha}{\lambda_s} \quad 5.3$$

Where:

- f = Frequency
- α = Failure mode ratio. The probability, expressed as a decimal fraction, that the part or item will fail in the identified mode.
- λ_p = Part failure rate.
- λ_s = Total system failure rate.

The results of the analysis for our OWT are summarized in the Criticality Matrix shown in Figure 34, in which three risk areas can be identified:

- Green area (Low occurrence and low severity) indicates that the risk associated to that failure mode located on it, is acceptable or well controlled. This area refers to those placed in minor severity with frequency from I to III, marginal severity with frequency I and II, critical severity with frequency I.
- Red area (High occurrence and high severity) indicates that actions must be taken to decrease the severity associated to that failure mode and occurrence of the failure modes placed on it. This area refers to those placed in marginal severity with frequency V, in critical severity with frequency IV and V and catastrophic severity with frequency from III to V.
- Yellow area (Medium risk) gathers those failure modes which must be monitored and controlled. This area refers to those modes placed in minor severity with frequency IV and V, marginal severity with frequency III and IV, critical severity with frequency II and III, and catastrophic severity with frequency I and II.

The matrix provides a way to identify and compare failure modes, with respect to their associated severity and frequency. Severity degrees assigned to failure modes are described in Table 12. A classification of frequency is given in Table 13.

The matrix will provide a way to identify and compare failure modes each other respect to their associated severity and frequency.

Frequency	Frequent (V)		1	1	
	Reasonably probably (IV)				
	Occasional (III)	3	4	2	1
	Remote (II)	6			1
	Extremely Unlikely (I)	8	1	6	
		Minor	Marginal	Critical	Catastrophic
		Severity			

Figure 34. Risk Matrix

Severity	Definition	Value associated with RPN analysis
Catastrophic	A failure mode which causes death, system loss, severe environmental damage, damage over 900.000€ or downtime over 2 days.	250
Critical	A failure mode which causes severe injury, major system or environmental damage, mission loss, damage over 90.000€ but less than 900.000€ and loss of availability between 24 hours and 7 days.	175
Marginal	A failure mode which causes minor injury, minor system and environmental damage, mission degradation, damage between 90.000€ and 9000€ and loss of availability between 24 hours and 4 hours.	100
Minor	Only unscheduled maintenance or repair, damage under 9000€ and loss of availability under 4 hours.	25

Table 12. Severity classification

5.6 FMECA process

The 'bottom-up' procedure for component FMECA is the following:

1. Construct a OWT FMECA system tree;
2. Identify all potential items;
3. Evaluate failure modes (from mode library) of each component;
4. Evaluate the local effect for each component failure mode;
5. Roll-up all local effects at higher level (at higher level, the rolled-up effect becomes the failure mode at that level);
6. Repeat step 5 until system level;
7. For each end effect at system level identify the detection, severity and occurrence;
8. Build down the FMECA by transferring all the end system effects and severity to sub-system, assembly and component level.

<i>Frequency</i>	<i>Description</i>	<i>Value associated with RPN analysis</i>
Frequent	A high probability of occurrence during the item operative time interval. High probability may be defined as a single failure mode probability greater than 0.20 of the overall probability of failure during the item operative time interval.	4
Reasonably probable	A moderate probability of occurrence during the item operative time interval. Probable may be defined as a single failure mode probability of occurrence which is more than 0.10 but less than 0.20 of the overall probability of failure during the item operative time.	3
Occasional	An occasional probability of occurrence during item operative time interval. Occasional probability may be defined as a single failure mode probability of occurrence which is more than 0.01 but less than 0.10 of the overall probability of failure during the item operative time.	2
Remote	An unlikely probability of occurrence during item operative time interval. Remote probability may be defined as a single failure mode probability of occurrence which is more than 0.001 but less than 0.01 of the overall probability of failure during the item operative time.	1
Extremely unlikely	A failure whose probability of occurrence is essentially zero during item operative time interval. Extremely unlikely may be defined as a single failure mode probability of occurrence which is less than 0.001 of the overall probability of failure during the item operative time.	0

Table 13. *Frequency classification*

5.7 Limitations

FMEA takes into consideration only non-simultaneous failure modes. In other words, each failure mode is considered individually, assuming that other system items work as usual. Effects of multiple item failures on wind turbine functions and redundant items are not covered by FMEA. These events are usually studied for those systems or sub-systems that perform safety functions by the Fault Tree Analysis (FTA) and Markov analysis.

5.8 FMECA construction

In order to develop a FMECA it must be selected an appropriate worksheet, which includes those required parameters to get the analysis objectives. Also, it has been kept in mind the data available and item indenture level. The selected worksheet is based on the formats indicated in tasks 101 and 102 (Table 14) of the MIL-STD-1629. It contains a heading which shows information such as:

<i>Header Field</i>	<i>Description</i>
System	Item for which FMECA worksheet is completed.
Indenture Level	Level at which system is analyzed.
Compiled By	Team members responsible for developing FMECA worksheet.
Date	Date on which FMECA worksheet is developed or was last updated.
Sheet _ of _	Number of FMECA worksheet pages.

Table 14. *Worksheet information header*

General worksheet columns contain information about how system operation is affected. These columns are described in the following table:

<i>Field</i>	<i>Description</i>
Item/Functional Identification	Name of the item for which failure modes and effects are to be identified.
Failure Mode	Failure modes that have been identified for each indenture level to be analyzed based on stated requirements and failure definitions.
Local Effect	Consequences that the failure mode has on the local operation, function or status of the local item that is being analyzed.
Next Effect	Consequences that a failure mode has on the operation, function or status of the items in the indenture level above the one under consideration.
End Effect	Consequences that a failure mode has on the operation, function or status of the highest indenture level.
Field	Description
Cause of Failure	Causes for each failure mode, which are either the reasons for the failure or those which initiate the processes that lead to the failure. Multiple causes can be assigned to each failure mode.
Severity	Qualitative measure of how serious the consequences of the failure mode are on the system. This severity is classified in minor, marginal, critical and catastrophic.
Occurrence	Value that indicates how frequently the failure mode under analysis is likely to occur. The rating is divided in five: Extremely unlikely, remote, occasional, reasonable probable and frequent.
Detection	Value that indicates how often the failure mode under analysis can be detected. It goes from 1 (almost certain) to 10 (absolutely impossible).
Risk Priority Number (RPN)	Criticality value calculated for each failure mode by taking the product of severity, detection and occurrence. RPNs have values between 1 and 10.000. Higher RPNs indicate more critical failure modes.
Mode Percentage	Percentage that corresponds to each failure mode of the item under analysis.
Item Failure Rate (Item FR)	Failures per million hours of a specific item.
Mode Failure Rate (Mode FR)	The number of occurrences of a specific failure mode over a time period (million hours)
Item Criticality	Four values where each one is the sum of the Mode Criticality numbers for all failure modes with the same severity level (Catastrophic, Critical, Marginal and Minor).

Table 15. General description of the worksheet columns

5.9 Results

In this paragraph, the main results of the FMECA are shown. The completed analysis is reported in Appendice 3. Bibliografy as [134], [135], [136], [137], [138], [139], [140] have helped to develop the FMECA study.

All FMECA results can be shown in an attached pdf file which shows all failure modes analysed for each item until the failure modes arrives the offshore wind turbine. This pdf file has 580 pages.

5.9.1 System Tree Identifier Overview

The results of next paragraphs are related to the following hierarchical structure Figure 35:

Name
[-] WTG
[+] ROTOR MODULE
[+] DRIVE TRAIN MODULE
[+] NACELLE MODULE
[+] STRUCTURAL MODULE
[+] POWER MODULE
[+] CONTROL & SAFETY SYSTEM GH
[+] CONTROL & COMMUNICATION SYSTEM
[+] CONDITION MONITORING SYSTEM
[+] AUXILIARY EQUIPMENT
[+] WIND FARM SYSTEM

Figure 35. OWT Structure

5.9.2 Risk matrix and Criticality evaluation

A risk matrix is probably one of the most widespread tools for risk evaluation. The Figure 34 reports the number of failure modes that lead to the end effect with each particular combination of severity and frequency values. Figure 34 shows seven failure modes located in yellow zones where actions to control or monitor them must be taken (three of them are: The Drive Train Module Failure, the Power Module Failure and the Structural Module Failure). Twenty-four failure modes, whose risk is considered to be low are in the green areas. Three failure modes are located in the red areas where mitigating actions must be taken (The Auxiliary Power Equipment Failure in Marginal-Frequent,

The Rotor Module Failure in Critical-Frequent, and the Nacelle Module Failure in Catastrophic-Occasional). The results of the Auxiliary Power Equipment are due to the large number of items contained within it, while for the Rotor Module this result is due to the high failure rate of the Blades assembly. For the Nacelle Module Failure, the reason why it is placed in a red zone is because the Nacelle is one of the main structures of the WT where the majority of the main assemblies are located.

From what is presented in section 3.4.7, the MTBF of the system is 3723.37 h (2.37 failures per year). For this reason, the time until system fails has been taken as the mission time.

As mentioned in previous sections, another quantitative analysis has been performed, the results of which are shown in Figure 36. From Figure 36, it can be seen that:

- Six marginal failure modes have the highest criticality number for the system.
- Nine critical failure modes have almost the same criticality number as Marginal failure modes.
- Seventeen 'minor' failure modes have more than three times criticality compared to the two 'Catastrophic' failure modes, but less than half the value of criticality number compared to Marginal and Critical failure modes.

Equation (5.4) is derived from Equation. (5.1), (5.2) and (5.3), and it can help to explain why the item criticality numbers are so high for the less severe modes:

$$C_r = \sum_n^j (f_n * t * \beta * \lambda_s) \quad 5.4$$

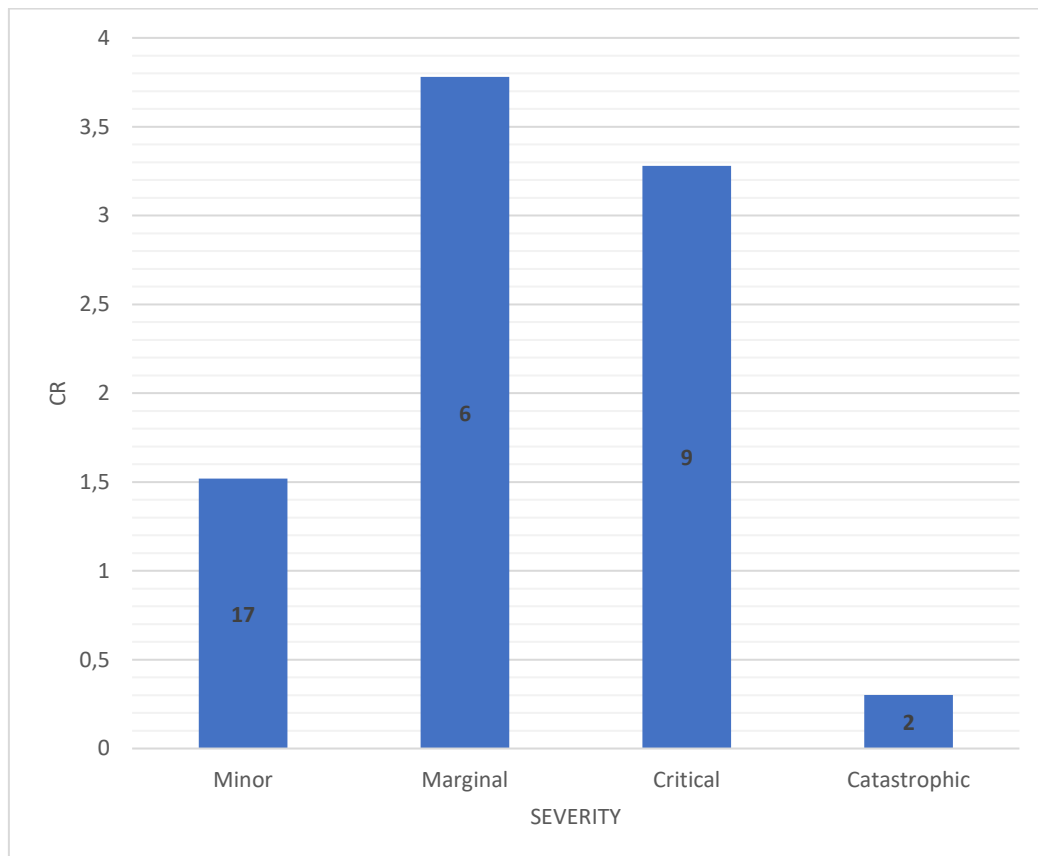

Figure 36. Item Criticality number (C_r) distribution

Considering that "t" does not change, C_r is constant and values are the same for all failure modes, one can obtain Eq. (5.5):

$$C_r = k * \sum_n^j f_n \quad 5.5$$

Therefore, for the marginal classification, high values of frequency and a high number of failure modes are the reason for high item criticality numbers.

5.9.3 Severity Distribution

In the following severity distribution pie diagram is shown how failure modes are distributed according to severity classification. This overall rating gives us a clear idea of the proportion of failure modes that affects to the wind turbine respect to severity categories. As it can be seen in Figure 37, the highest percentage of failure modes matches with minor severity class while almost the other half of the graph matches with marginal and critical severity class. The remaining slice represents those failure modes that are classified as catastrophic. Looking at the graphic below, a first consideration is that the half of failure modes may cause an important loss in availability, a mission degradation or a mission loss and even damage to the system, personnel and environment. Thus, actions must be taken to decrease the severity of failure mode consequences introducing some security procedures or even changes in design.

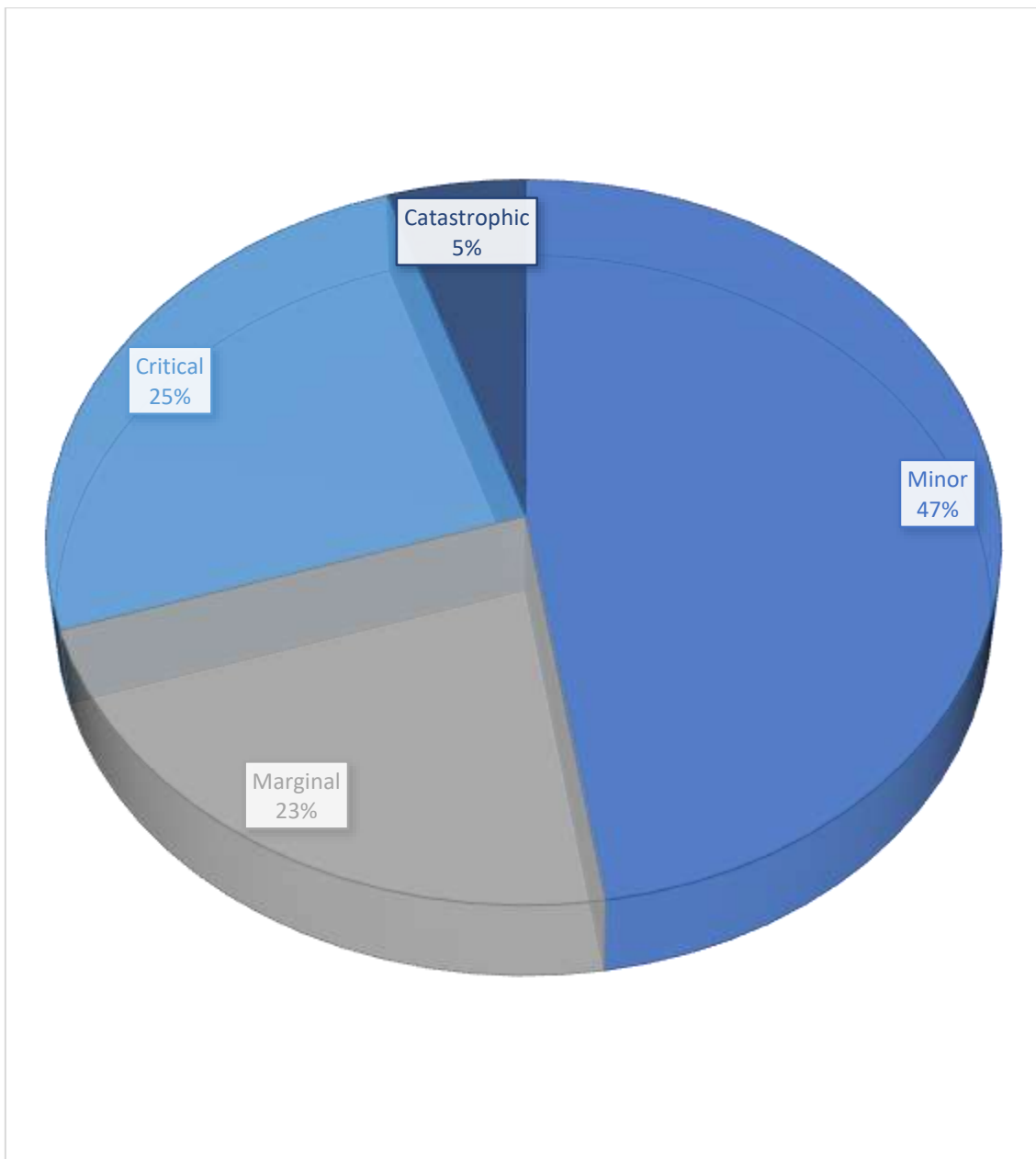

Figure 37. Severity Distribution Pie Diagram

5.9.4 Failure Mode Causes

In Figure 38 are shown the ten most frequent failure mode causes for an off-shore wind turbine. The most frequent causes are vibration, fatigue and contaminants, and these are due to the huge dimension of the turbine and where it is located. This means that, since the wind turbine has a big dimension and is located in an adverse environment, a small unbalance in a subsystem or assembly may lead to vibration and then fatigue, strains and their subsequent failures.

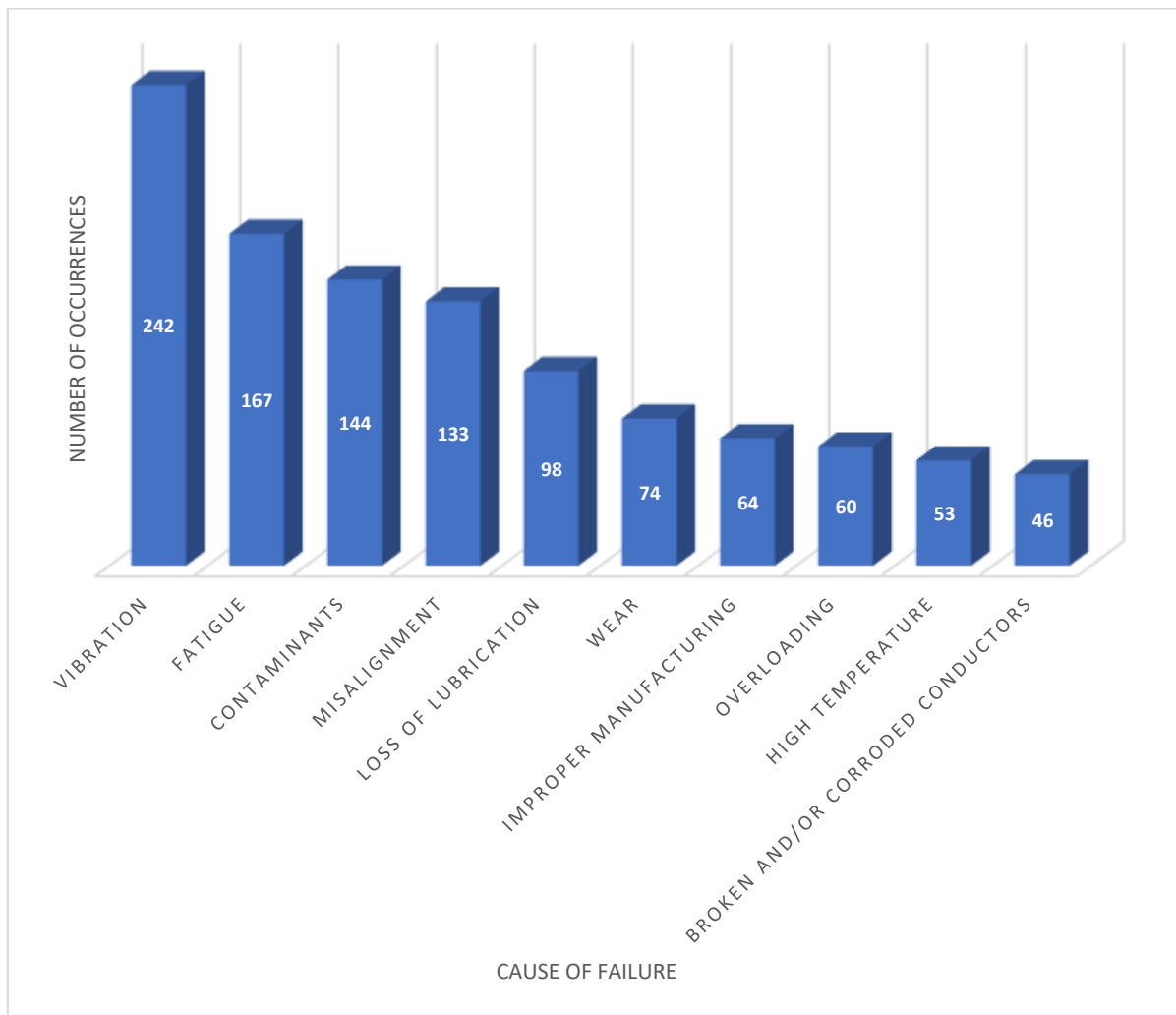

Figure 38. Top 10 Failure Mode Causes

5.9.5 Mode Criticalities at system level

The ten modes with the highest criticalities are reported in Figure 39. Blades are well known as the parts that most suffer in wind turbines due to their continuous work under adverse environmental conditions; in fact, Rotor Module Failure (which includes the Blades) is characterized by the highest mode criticality value (mode criticality of 2.88).

Unifying all Auxiliary Equipment failure modes would lead to the highest mode criticality (3.41), simply due to the large amount of assemblies contained in this sub-system; however, these failure modes have been sorted based on the equipment in which they can manifest.

Even with the aforementioned equipment separated, the second highest mode criticality belongs to Auxiliary Power Equipment Failure, while the third and fourth positions are taken by WT Auxiliary Equipment Failure and Air Conditioning Equipment Failure, respectively.

The remaining failures with the lowest values of mode criticality belong to Condition Monitoring System Failure, Control and Safety System Failure, Nacelle Module Failure, Drive Train Module Failure and Power Module Failure.

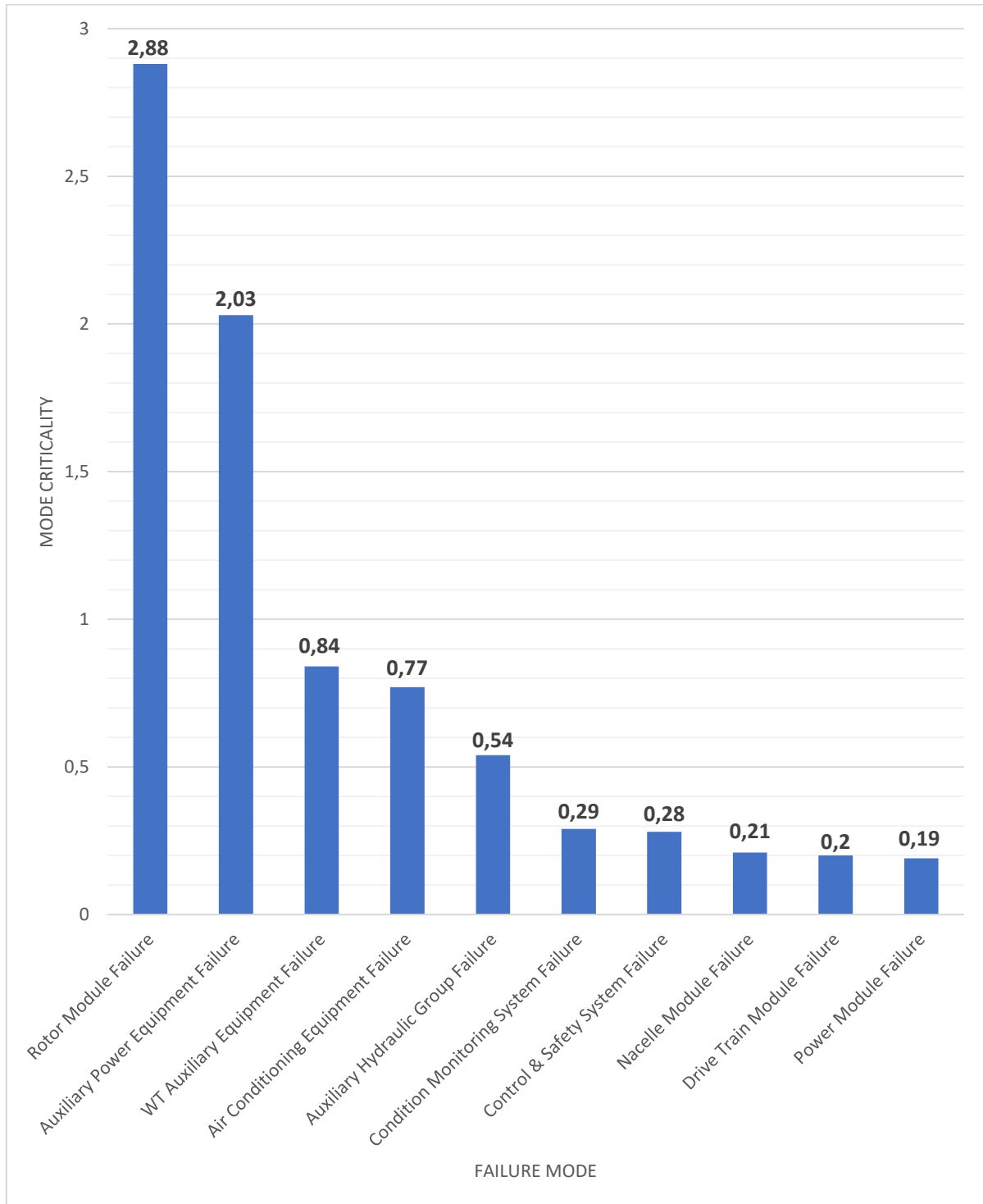

Figure 39. Top 10 Mode Criticalities

5.9.6 Risk Priority Number

RPN is a criticality study in which the severity, occurrence and detection are multiplied in order to obtain information about the riskiest failure modes. Thus, greater attention is paid to critical parts. Eq. (5.6) is used to obtain RPN numbers:

$$\text{RPN} = \text{Severity} * \text{Occurrence} * \text{Detection} \quad 5.6$$

Figure 40 shows the consequent risk priority classification with the highest RPNs of the OWT.

In this case, Rotor Module Failure is still in first position because of its high occurrence and severity and also its low detection level comparing to the others, followed now by the Structural Module Failure and the Nacelle Module Failure due to its high severity and low detection. The rest of the failure modes have such combinations that give them a gradual position on the graph until getting a value of 200 for the last two modes.

It is important to note that the mode criticality graph and the RPN graph give different lists of the riskiest failure modes of the OWT. This is because the mode criticality analysis focuses on the probability of occurrence, while the RPN analysis considers the detection parameter combined with severity and occurrence. All RPN values related to severity, occurrence and detection, and used to perform this analysis, are listed in Table 12, Table 13 and Table 16 respectively.

<i>Detection</i>	<i>Value associated with RPN analysis</i>	<i>Description</i>
Almost certain	1	Inspections will almost certainly detect a functional failure.
Very high	2	Very high chance the inspections will detect a functional failure.
High	3	High chance the inspections will detect a functional failure.
Moderately high	4	Moderately high chance the inspections will detect a functional failure.
Moderate	5	Moderate chance the inspections will detect a functional failure.
Low	6	Low chance the inspections will detect a functional failure.
Very low	7	Very low chance the inspections will detect a functional failure.
Remote	8	Remote chance the inspections will detect a functional failure.
Very remote	9	Very remote chance the inspections will detect a functional failure.
Absolutely impossible	10	Inspections will not and/or cannot detect a functional failure or there are no the inspections.

Table 16. *Detection classification*

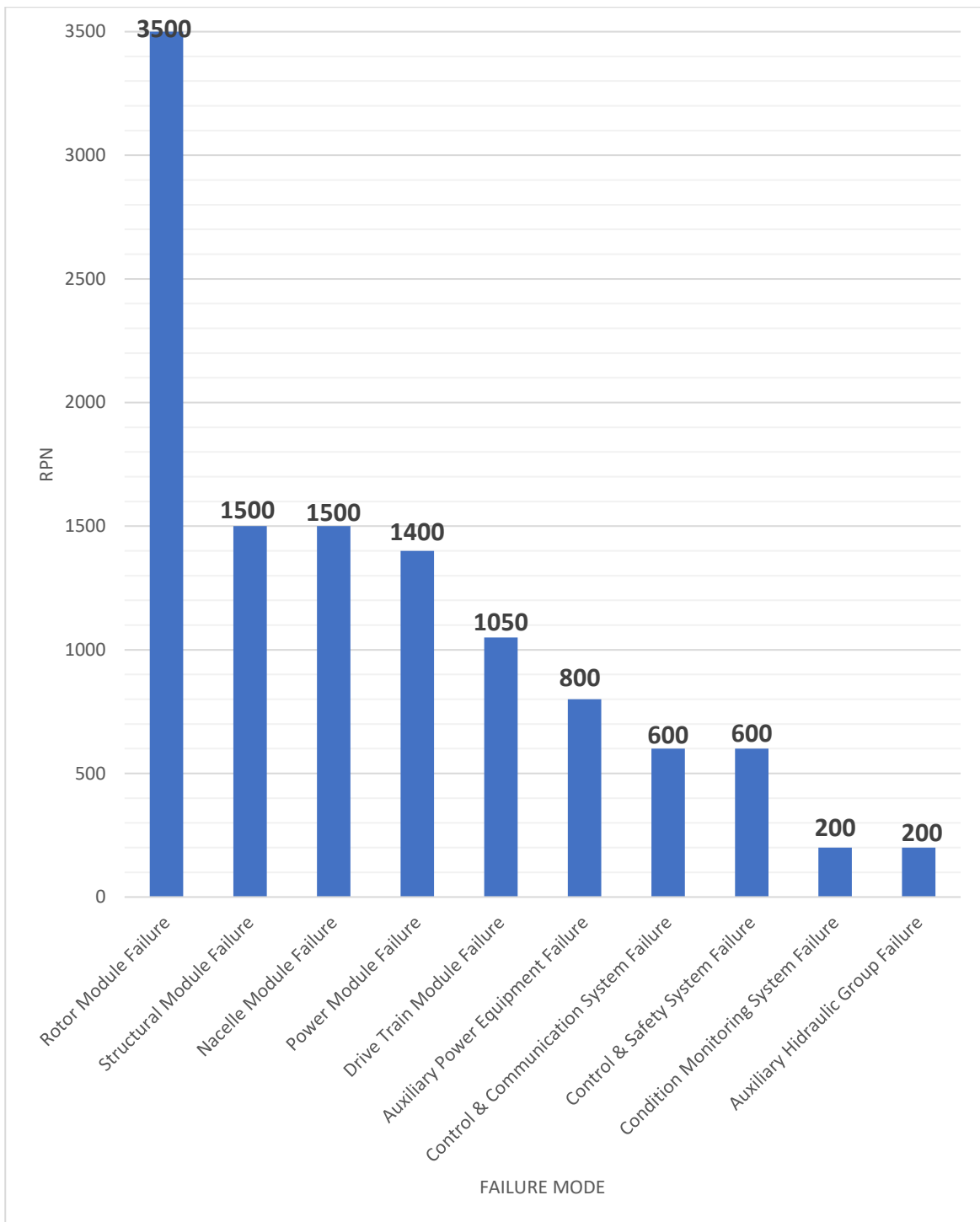

Figure 40. Top 10 RPN

5.9.7 Cost Analysis

In order to compensate the drawbacks, a cost analysis has been developed. The cost is evaluated for each effect of the failure mode, including consumables cost, charter the kind of vessel that is used for the preventive tasks, crew cost, energy losses cost and transportation cost.

Costs are measured in euros (€). Special attention has been paid to those activities or resources which play an important role in offshore maintenance: for instance, the energy losses during activity maintenance have been taken under consideration as well as fuel consumptions. All costs have been assumed under a

literature review [141], [142], [143], [144], [145], [146], [147], [148], [149], [150], [151]. Eq. (5.7) shows how the cost has been based on several associated costs.

$$C = C_{Item} + C_{maintenance} + C_{transportation} + C_{Crew} + C_{Losses} + C_{Design Control} + C_{Mobilization} \quad 5.7$$

C_{Item} (€): cost of the item which has to be replaced.

$C_{maintenance}$ (€): Assuming that vessels and equipment are needed, it is considered costs such as: rental of vessels and equipment needed to perform the replacement, materials that the crew need to carry out the task.

$C_{transportation}$ (€): it is based on transportation from the harbor to wind farm.

$$C_{Transportation} = d \cdot C_1 \quad 5.8$$

d = distance from harbor to wind farm and come back (Km)

C_1 = Fuel cost(€/Km)

C_{Crew} (€):

$$C_{Crew} = t \cdot C_d(t_d + t_0 + t_r) \quad 5.9$$

t = number of technicians

C_d = cost technicians per hour (€/hours)

t_d = transportation time, round trip (hours)

t_0 = time to adjust the actions (hours). It will be assumed 2 hours

t_r = time to replaced the failed item (hours). For this time will be got the MTTR of each item.

C_{Losses} (€):

$$C_{Losses} = (t_d + t_0 + t_r) \cdot C_L \quad 5.10$$

$C_L = W \cdot E \cdot C_{factor}$

W = power ratio(MW)

E = Electricity price = €/MWh

$C_{Design Control}$ (€):

Unless the failure is never produced, the cost which managers try to keep without downtime the wind turbine should be included, such as the condition monitoring system that is designed to predict failures before theirs are shown. Cost of the equipment which is necessary to detect the failure prior its occurs.

It is assumed an average value of 50.000€ for a remote condition monitoring system but it is designed by ourselves with the detection and location of damages methodology

$C_{Mobilization}$ (€):

The mobilization cost is assumed different for each failure and depending on the kind of vessel that is selected for the replacement. In this cost is included all costs involved with port, insurance and operation costs.

C_d = Technicians Cost (€/hour)	90 €/hour
Electricity Price (€/MWh)	83 €/MWh
Capacity Factor	35%

Table 17. General Assumptions

At the beginning of analysis, it has been assumed a distance from harbor to wind farm of 30km.

	CTV	FSV	Crane Vessel	Jack-up
Fuel Cost, round trip(€)	145,72€	137,62€	161,91€	222,63€
Charter Cost(€)	3.373€	8.961€	59.775€	94.211€
Number of technicians	4	6	8	8
Mobilization Cost(€)	0€	30.000€	45.000€	57.000€
t_d = Transportation time, round trip(hours)	1,3	3	6,69	5,4

Table 18. Vessel Features

Firstly, it is assumed that the weather window is always perfect to develop the replacement and there is not any environmental condition by which crew must wait in onshore (e.g. wave height). Three vessels have been selected in order to carry out the replacement depending on the item which has to be replaced.

- CTV Crew transfer Vessel (1):
This vessel is selected for the replacement of items with small and low weight. The first role is to transport crew to the OWT. It is only possible transport items of a few tones.

Several characteristics are assumed such as:

Operational Speed=2,4 knot

Fuel consumption= 0,24 mt/h

- FSV Field Support Vessel (2):
The vessel could be available for higher weather condition than CTV. It provides prompt attention to emergencies and is used to replace items with a moderate weight. It has a small crane that could be used in order to get up items to the OWT.

Several characteristics are assumed such as:

Operational Speed=13,5 knot

Fuel consumption= 0,2 mt/h

- Crane vessel (3):

This vessel has a crane which could weigh up to 30t. This kind of vessel is used to replace for instance the Generator and the Gearbox. The vessel has a lot of facilities for the crew and could have a length of 100m.

Several characteristics are assumed such as:

Operational Speed=7,8 knot

Fuel consumption= 0,4 mt/h

- Jack-Up (4):

Jack-Up vessel is used to great replacement as the Structural Module.

The crane capacity is of eight hundred tones. This kind of vessel will only be used when a problem has been found on the foundations.

Several characteristics are assumed such as:

Operational Speed=11 knot

Fuel consumption= 0,55 mt/h

The following Table 19 shows the cost that can be required for each failure mode found. As can be seen, the blades failure is the most expensive failure mode because it entails the jack-up vessel and a lot of labour hours. Blades are the most expensive component due to the design, size, weight and assembly to the rotor module. A classification depending on the cost have been done in the Table 20. Then the reliability and failure modes must be checked deeply in these parts.

Failure Mode	1	4	5	6	7	10	12	14	18	22	26	32	35	36	38	40
	SCADA Failure	CONTROL & COMMUNICATION SYSTEM Failure	CONTROL & SAFETY SYSTEM GH Failure	POWER MODULE Failure	STRUCTURAL MODULE Failure	Loose Converter	Loose Gearbox	Loose Generator	COOLING EQUIPMENT Failure	AUXILIARY POWER EQUIPMENT Failure	YAW SYSTEM Failure	POWER MODULE Overheating	BLADES Failure	NACELLE MODULE Failure	ROTOR MODULE Failure	DRIVE TRAIN MODULE Failure
Total Cost K€=	23,4	45,1	10,0	675,8	2486,1	1067,7	1948,4	797,5	11,9	74,9	288,2	675,8	3966,8	251,6	1075,7	618,4
Cr=	17500,0	33346,7	555,0	522000,0	2249150,0	851700,0	1797350	584800,0	3450,0	25842,4	212500,0	522000,0	3774000,0	203625,0	891820,0	471929,0
Cs=	0,0	3373,3	3373,3	59775,0	94211,5	128423,0	59775,0	59775,0	3373,3	8962,0	8962,0	59775,0	94211,5	8962,0	59775,0	59775,0
C1=	0,0	145,7	145,7	523,8	1935,8	261,9	523,8	2095,3	145,7	237,6	237,6	523,8	967,9	237,6	1309,6	523,8
CCrew=	1260,0	3034,8	1908,0	12153,6	35431,2	8100,0	10360,8	49953,6	1432,8	4611,6	3855,6	12153,6	25394,4	3974,4	31500,0	6625,8
CLosses=	2614,5	3148,6	1979,6	6304,7	18379,9	4201,9	5374,7	25913,4	1486,5	3189,7	2666,8	6304,7	13173,3	2749,0	16340,6	4582,8
d(km)=	30,0	30,0	30,0	30,0	30,0	30,0	30,0	30,0	30,0	30,0	30,0	30,0	30,0	30,0	30,0	30,0
td(hours)=	1,0	1,3	1,3	6,7	5,4	6,7	6,7	6,7	1,3	2,4	2,4	6,7	16,2	2,4	6,7	2,4
t0(hours)=	2,0	2,0	2,0	2,0	2,0	2,0	2,0	2,0	2,0	2,0	2,0	2,0	2,0	2,0	2,0	2,0
tr(hours)=	4,0	5,1	2,0	8,2	41,8	2,6	5,7	60,7	0,7	4,1	2,7	8,2	17,1	3,0	35,1	7,9
Ttotal	7,0	8,4	5,3	16,9	49,2	11,3	14,4	69,4	4,0	8,5	7,1	16,9	35,3	7,4	43,8	12,3
Type of transportation.	-	1,0	1,0	3,0	4,0	3,0	3,0	3,0	1,0	2,0	2,0	3,0	4,0	2,0	3,0	3,0

Table 19. Cost Analysis on several assemblies of the OWT

	<i>Failure Mode</i>	<i>Cost [k€]</i>
1	BLADES Failure	3966,8
2	STRUCTURAL MODULE Failure	2486,1
3	Loose Gearbox	1948,4
4	ROTOR MODULE Failure	1075,7
5	Loose Converter	1067,7
6	Loose Generator	797,5
7	POWER MODULE Failure	675,8
8	POWER MODULE Overheating	675,8
9	DRIVE TRAIN MODULE Failure	618,4
10	YAW SYSTEM Failure	288,2
11	NACELLE MODULE Failure	251,6
12	AUXILIARY POWER EQUIPMENT Failure	74,9
13	CONTROL & COMMUNICATION SYSTEM Failure	45,1
14	SCADA Failure	23,4
15	COOLING EQUIPMENT Failure	11,9
16	CONTROL & SAFETY SYSTEM GH Failure	10,0

Table 20. *Classification of most expensive failure modes*

5.9.8 FMECA results

The FMECA results are shown in the following Table 21, Table 22 and Table 23. Only the failure modes that arrive to the OWT are shown.

Item/Functional Identification	Failure Mode	Local Effect	Next Effect	End Effect	Cause of Failure	Severity	Occurrence	Detection	RPN	Mode Percentage	Item FR	Mode FR	Item Criticality
WTG	Loss of wire-speed delivery of concurrent data, voice, video and wireless services	Wind Turbine Information Loss	Wind Turbine Information Loss	Wind Turbine Information Loss		Minor	Extremely Unlikely	1	0	0.02	2479.379349	0.500000	Catastrophic = 122862.73, Critical = 757762.79, Marginal = 6.77E+006, Minor = 1.52E+006
	Loss of prioritization and traffic-monitoring capabilities	Wind Turbine Information Loss	Wind Turbine Information Loss	Wind Turbine Information Loss		Minor	Extremely Unlikely	1	0	0	2479.379349	0.010000	Catastrophic = 122862.73, Critical = 757762.79, Marginal = 6.77E+006, Minor = 1.52E+006
	Data can not be saved or transferred	Wind Turbine information loss	Wind Turbine information loss	Wind Turbine information loss		Minor	Remote	1	25	0.58	2479.379349	14.295240	Catastrophic = 122862.73, Critical = 757762.79, Marginal = 6.77E+006, Minor = 1.52E+006
	CONTROL & COMMUNICATION SYSTEM Failure	Subsystems out of control	Subsystems out of control	Subsystems out of control		Marginal	Occasional	3	600	1.7	2479.379349	42.048618	Catastrophic = 122862.73, Critical = 757762.79, Marginal = 6.77E+006, Minor = 1.52E+006
	CONTROL & SAFETY SYSTEM GH Failure	Wind Turbine and Personnel on risk	Wind Turbine and Personnel on risk	Wind Turbine and Personnel on risk		Marginal	Occasional	3	600	3.09	2479.379349	76.622543	Catastrophic = 122862.73, Critical = 757762.79, Marginal = 6.77E+006, Minor = 1.52E+006
	POWER MODULE Failure	Wind Turbine does not generate energy	Wind Turbine does not generate energy	Wind Turbine does not generate energy		Critical	Occasional	4	1400	2.05	2479.379349	50.853343	Catastrophic = 122862.73, Critical = 757762.79, Marginal = 6.77E+006, Minor = 1.52E+006
	STRUCTURAL MODULE Failure	Wind Turbine Failure	Wind Turbine Failure	Wind Turbine Failure		Catastrophic	Remote	6	1500	1	2479.379349	24.824705	Catastrophic = 122862.73, Critical = 757762.79, Marginal = 6.77E+006, Minor = 1.52E+006
	No output power	No output power	No output power	No output power		Critical	Extremely Unlikely	1	0	0.07	2479.379349	1.756740	Catastrophic = 122862.73, Critical = 757762.79, Marginal = 6.77E+006, Minor = 1.52E+006
	No access to wind turbine	No access to Wind Turbine	No access to Wind Turbine	No access to Wind Turbine		Minor	Extremely Unlikely	1	0	0.05	2479.379349	1.152969	Catastrophic = 122862.73, Critical = 757762.79, Marginal = 6.77E+006, Minor = 1.52E+006
	Loose Converter	Wind Turbine Failure	Wind Turbine Failure	Wind Turbine Failure		Critical	Extremely Unlikely	2	0	0	2479.379349	0.022832	Catastrophic = 122862.73, Critical = 757762.79, Marginal = 6.77E+006, Minor = 1.52E+006
	No access to Nacelle	No access to Nacelle	No access to Nacelle	No access to Nacelle		Critical	Occasional	1	350	3.25	2479.379349	80.471552	Catastrophic = 122862.73, Critical = 757762.79, Marginal = 6.77E+006, Minor = 1.52E+006
	Loose Gearbox	Wind Turbine Failure	Wind Turbine Failure	Wind Turbine Failure		Critical	Extremely Unlikely	2	0	0	2479.379349	0.011416	Catastrophic = 122862.73, Critical = 757762.79, Marginal = 6.77E+006, Minor = 1.52E+006
	Loose Cover	Wind Turbine Failure	Wind Turbine Failure	Wind Turbine Failure		Critical	Extremely Unlikely	2	0	0	2479.379349	0.022832	Catastrophic = 122862.73, Critical = 757762.79, Marginal = 6.77E+006, Minor = 1.52E+006
	Loose Generator	Wind Turbine Failure	Wind Turbine Failure	Wind Turbine Failure		Critical	Extremely Unlikely	2	0	0	2479.379349	0.011416	Catastrophic = 122862.73, Critical = 757762.79, Marginal = 6.77E+006, Minor = 1.52E+006

Table 21. FMECA of the Offshore Wind Turbine. Part 1

Item/Functional Identification	Failure Mode	Local Effect	Next Effect	End Effect	Cause of Failure	Severity	Occurrence	Detection	RPN	Mode Percentage	Item FR	Mode FR	Item Criticality
	Loose Brake Assembly	Wind Turbine is not able to stop moving Nacelle	Wind Turbine is not able to stop moving Nacelle	Wind Turbine is not able to stop moving Nacelle		Marginal	Extremely Unlikely	2	0	0	2479.379349	0.011416	Catastrophic = 122862.73, Critical = 757762.79, Marginal = 6.77E+006, Minor = 1.52E+006
	Meteorological data loss	Meteorological Data Loss	Meteorological Data Loss	Meteorological Data Loss		Minor	Occasional	1	50	2.15	2479.379349	53.215202	Catastrophic = 122862.73, Critical = 757762.79, Marginal = 6.77E+006, Minor = 1.52E+006
	GROUNDING EQUIPMENT Failure	Wind Turbine and Personnel on risk	Wind Turbine and Personnel on risk	Wind Turbine and Personnel on risk		Marginal	Occasional	3	600	8.38	2479.379349	207.692654	Catastrophic = 122862.73, Critical = 757762.79, Marginal = 6.77E+006, Minor = 1.52E+006
	COOLING EQUIPMENT Failure	Wind Turbine subsystems Overheating	Wind Turbine subsystems Overheating	Wind Turbine subsystems Overheating		Marginal	Occasional	1	200	8.35	2479.379349	206.954171	Catastrophic = 122862.73, Critical = 757762.79, Marginal = 6.77E+006, Minor = 1.52E+006
	It does not provide lighting protection in the event of lighting failure	Wind Turbine and Personnel on risk	Wind Turbine and Personnel on risk	Wind Turbine and Personnel on risk		Minor	Remote	3	75	0.14	2479.379349	3.557834	Catastrophic = 122862.73, Critical = 757762.79, Marginal = 6.77E+006, Minor = 1.52E+006
	CONDITION MONITORING SYSTEM Failure	No information about Wind Turbine condition	No information about Wind Turbine condition	No information about Wind Turbine condition		Minor	Occasional	4	200	3.15	2479.379349	78.068462	Catastrophic = 122862.73, Critical = 757762.79, Marginal = 6.77E+006, Minor = 1.52E+006
	In the event of fire firefighting system does not work	Wind Turbine and Personnel on risk	Wind Turbine and Personnel on risk	Wind Turbine and Personnel on risk		Minor	Remote	3	75	0.63	2479.379349	15.645205	Catastrophic = 122862.73, Critical = 757762.79, Marginal = 6.77E+006, Minor = 1.52E+006
	AUXILIARY POWER EQUIPMENT Failure	No Power in Wind Turbine sections	No Power in Wind Turbine sections	No Power in Wind Turbine sections		Marginal	Reasonably Probable	2	600	13.78	2479.379349	341.731500	Catastrophic = 122862.73, Critical = 757762.79, Marginal = 6.77E+006, Minor = 1.52E+006
	Hub Condition Monitoring Failure	No information about Hub Condition	No information about Hub Condition	No information about Hub Condition		Minor	Extremely Unlikely	3	0	0.01	2479.379349	0.228554	Catastrophic = 122862.73, Critical = 757762.79, Marginal = 6.77E+006, Minor = 1.52E+006
	AUXILIARY TOP CABINET HEATING AND COOLING Failure	Wind Turbine subsystems Overheating	Wind Turbine subsystems Overheating	Wind Turbine subsystems Overheating		Minor	Remote	1	25	0.66	2479.379349	16.344646	Catastrophic = 122862.73, Critical = 757762.79, Marginal = 6.77E+006, Minor = 1.52E+006
	WT AUXILIARY EQUIPMENT Failure	Secondary function of Wind Turbine affected	Secondary function of Wind Turbine affected	Secondary function of Wind Turbine affected		Minor	Frequent	1	100	6.97	2479.379349	172.739802	Catastrophic = 122862.73, Critical = 757762.79, Marginal = 6.77E+006, Minor = 1.52E+006
	AUXILIARY HYDRAULIC GROUP Failure	Secondary function of Wind Turbine affected	Secondary function of Wind Turbine affected	Secondary function of Wind Turbine affected		Marginal	Occasional	1	200	5.91	2479.379349	146.504881	Catastrophic = 122862.73, Critical = 757762.79, Marginal = 6.77E+006, Minor = 1.52E+006
	YAW SYSTEM Failure	Wind turbine can not be rotated in order to get the optimal position of wind	Wind turbine can not be rotated in order to get the optimal position of wind	Wind turbine can not be rotated in order to get the optimal position of wind		Marginal	Occasional	3	600	1.91	2479.379349	47.294639	Catastrophic = 122862.73, Critical = 757762.79, Marginal = 6.77E+006, Minor = 1.52E+006
	SCADA Server UPS does not provide redundancy in the event of a power supply failure	SCADA Server UPS does not provide redundancy in the event of a power supply failure	SCADA Server UPS does not provide redundancy in the event of a power supply failure	SCADA Server UPS does not provide redundancy in the event of a power supply failure		Minor	Extremely Unlikely	1	0	0.01	2479.379349	0.371500	Catastrophic = 122862.73, Critical = 757762.79, Marginal = 6.77E+006, Minor = 1.52E+006

Table 22. FMECA of the Offshore Wind Turbine. Part 2

Item/Functional Identification	Failure Mode	Local Effect	Next Effect	End Effect	Cause of Failure	Severity	Occurrence	Detection	RPN	Mode Percentage	Item FR	Mode FR	Item Criticality
	SCADA User interface devices out of control	Wind Turbine Information Loss	Wind Turbine Information Loss	Wind Turbine Information Loss		Minor	Extremely Unlikely	1	0	0.04	2479.379349	0.870400	Catastrophic = 122862.73, Critical = 757762.79, Marginal = 6.77E+006, Minor = 1.52E+006
	No access to Hub	No access to Hub	No access to Hub	No access to Hub		Minor	Extremely Unlikely	1	0	0.08	2479.379349	1.906450	Catastrophic = 122862.73, Critical = 757762.79, Marginal = 6.77E+006, Minor = 1.52E+006
	Data loss about grid condition	Data loss about grid condition	Data loss about grid condition	Data loss about grid condition		Minor	Extremely Unlikely	1	0	0	2479.379349	0.000000	Catastrophic = 122862.73, Critical = 757762.79, Marginal = 6.77E+006, Minor = 1.52E+006
	POWER MODULE Overheating	Wind Turbine subsystems Overheating	Wind Turbine subsystems Overheating	Wind Turbine subsystems Overheating		Critical	Extremely Unlikely	1	0	0.04	2479.379349	1.081932	Catastrophic = 122862.73, Critical = 757762.79, Marginal = 6.77E+006, Minor = 1.52E+006
	Loss of communications	Loss of communications	Loss of communications	Loss of communications		Minor	Remote	1	25	0.67	2479.379349	16.647662	Catastrophic = 122862.73, Critical = 757762.79, Marginal = 6.77E+006, Minor = 1.52E+006
	Meteorological Station loss	Meteorological Station loss	Meteorological Station loss	Meteorological Station loss		Minor	Extremely Unlikely	1	0	0	2479.379349	0.011416	Catastrophic = 122862.73, Critical = 757762.79, Marginal = 6.77E+006, Minor = 1.52E+006
	BLADES Failure	Wind Turbine is not able to place blades in right position	Wind Turbine is not able to place blades in right position	Wind Turbine is not able to place blades in right position		Marginal	Frequent	3	1200	30.74	2479.379349	762.162459	Catastrophic = 122862.73, Critical = 757762.79, Marginal = 6.77E+006, Minor = 1.52E+006
	NACELLE MODULE Failure	Wind Turbine Failure	Wind Turbine Failure	Wind Turbine Failure		Catastrophic	Remote	3	750	0.34	2479.379349	8.390416	Catastrophic = 122862.73, Critical = 757762.79, Marginal = 6.77E+006, Minor = 1.52E+006
	In case of dangerous malfunction, safety devices do not work	Wind Turbine and Personnel on risk	Wind Turbine and Personnel on risk	Wind Turbine and Personnel on risk		Minor	Occasional	3	150	1.06	2479.379349	26.397965	Catastrophic = 122862.73, Critical = 757762.79, Marginal = 6.77E+006, Minor = 1.52E+006
	ROTOR MODULE Failure	Wind Turbine Failure	Wind Turbine Failure	Wind Turbine Failure		Critical	Remote	5	875	0.67	2479.379349	16.734200	Catastrophic = 122862.73, Critical = 757762.79, Marginal = 6.77E+006, Minor = 1.52E+006
	ROTOR MODULE Improper accessibility	No maintenance can be done	No maintenance can be done	No maintenance can be done		Minor	Remote	1	25	0.34	2479.379349	8.321918	Catastrophic = 122862.73, Critical = 757762.79, Marginal = 6.77E+006, Minor = 1.52E+006
	DRIVE TRAIN MODULE Failure	Wind Turbine Failure	Wind Turbine Failure	Wind Turbine Failure		Critical	Occasional	3	1050	2.17	2479.379349	53.889858	Catastrophic = 122862.73, Critical = 757762.79, Marginal = 6.77E+006, Minor = 1.52E+006
ROTOR MODULE	HYDRAULIC PITCH SYSTEM Failure	BLADES Failure	Wind Turbine is not able to place blades in right position	Wind Turbine is not able to place blades in right position		Marginal	Reasonably Probable	1	300	58.6	787.218577	461.296088	Catastrophic = 0.00, Critical = 61899.81, Marginal = 2.82E+006, Minor = 30782.77
	HYDRAULIC PITCH SYSTEM Improper response	BLADES Failure	Wind Turbine is not able to place blades in right position	Wind Turbine is not able to place blades in right position		Marginal	Reasonably Probable	1	300	33.75	787.218577	265.720501	Catastrophic = 0.00, Critical = 61899.81, Marginal = 2.82E+006, Minor = 30782.77

Table 23. FMECA of the Offshore Wind Turbine. Par

6 Preventive Maintenance (PM)

During the Wind Turbine life, different types of maintenance tasks are required in order to retain or restore its operation. In this section, we explain how to apply the “NAVAIR 00-25-403” procedure to define the PM tasks for our OWT [81]. This standard explains a complete Reliability Centered Maintenance (RCM) process which can be applied for almost any system.

6.1 Definition

Preventive Maintenance looks at actions that can be used to extend the useful life of system with a good cost-benefit relation, whilst simultaneously ensuring the safety of the system. PM tasks are generally performed during an intended downtime, though they can also be performed during corrective maintenance and even while the system is running (Predictive Maintenance using non-destructive inspection techniques).

6.2 Preventive Maintenance Tasks Classification

6.2.1 Scheduled Tasks

Scheduled tasks are those which are performed in set intervals of time. These intervals can be measured in different units depending on how the system operates (e.g. cycles, time and events). The main units used in the Wind Turbine tasks are units of time: hours, days months and years. Scheduled tasks include:

- Servicing (S): this task involves the replenishment of consumables that are wasted overtime, as for example oil and fuel. Usually no further analysis should be done for these tasks due to they should be performed according to their manufacturer’s instructions, which include information about how often, how to do it, level of disassembly, operator skills and other maintenance requirements.
- Lubrication (L): this task is applied to those components that must be lubricated periodically according to design specifications. As for S tasks, manufacturers give the instructions to perform it as well as its intervals to be applied
- Hard Time (HT): It consists of the replacement or restoration of the item before it fails. This task is performed when the degradation of the item cannot be detected. The degradation phase of the item is called “Wear Out”, which shows different increases of the probability of failure with time depending on the type of component. The time to perform the task is established according to the consequences of the effects that the item failure causes. If the consequences are safety/environmental related, the limit time to perform the task will be established before the wear out age while if the consequences are operational/economic related the limit time will be flexibly established before the functional failure.
- Failure Finding (FF): this schedule task allows finding functional failures that have already occurred but are not apparent to the operators/maintainers, also called hidden failures. Emergency or back-up systems such as

firefighting system or pumps in the hydraulic system are examples of elements that are subjected to Failure Finding task.

6.2.2 On Condition Task

On Condition (OC) tasks are periodical or continuous inspections. In contrast to HT tasks, these have a well-defined degradation period where the potential failure indicates that a functional failure will occur. Periodic and continuous inspections ensure that the items work until a potential failure comes along, extending its useful life, and therefore decreasing its maintenance costs. Once the potential failure is found, the next inspections are performed with flexible intervals of time in order to find the right time to take corrective actions. Periodical inspections range from simple visual checks to non-destructive inspections which need specialized equipment. The most used continuous inspection in wind turbines is condition monitoring. Condition monitoring is usually used for failure modes whose functional failures have environmental/safety-related effects, as these needs to be continuously controlled.

6.3 Significant Function Selection

System failures may have different levels of function losses. Hence, functions are classified as “Significant Function (SF)” or “Non-SF”, depending on whether the consequences of these failures may lead to any losses of function, or effects, in terms of safety, environment, operations or economic impacts.

6.3.1 Significant Function (SF) Logic:

Function failures have been analysed through several questions which identify all significant failures. Items may have more than one significant function and each one should be analysed individually. Functions which are not significant are not taken into consideration. The logic diagram shown in Figure 41 and has been followed in order to identify all significant functions.

The diagram is composed of four questions, that point out which loss of function has adverse effects on safety, environment, operations and economic impacts— and if the function is already protected by an existing PM task. The significant function selection logic diagram is represented in Figure 42. All functions are followed through the diagram in order to classify them in “SF” or “Non-SF”. If the four questions’ in Figure 41 are answered as “No”, the function is classified as “Non-SF”. A positive answer is enough to consider the function as a “SF”. The SF Identification process ensures that all functions and effects have been taken into consideration before a Task Evaluation analysis is developed.

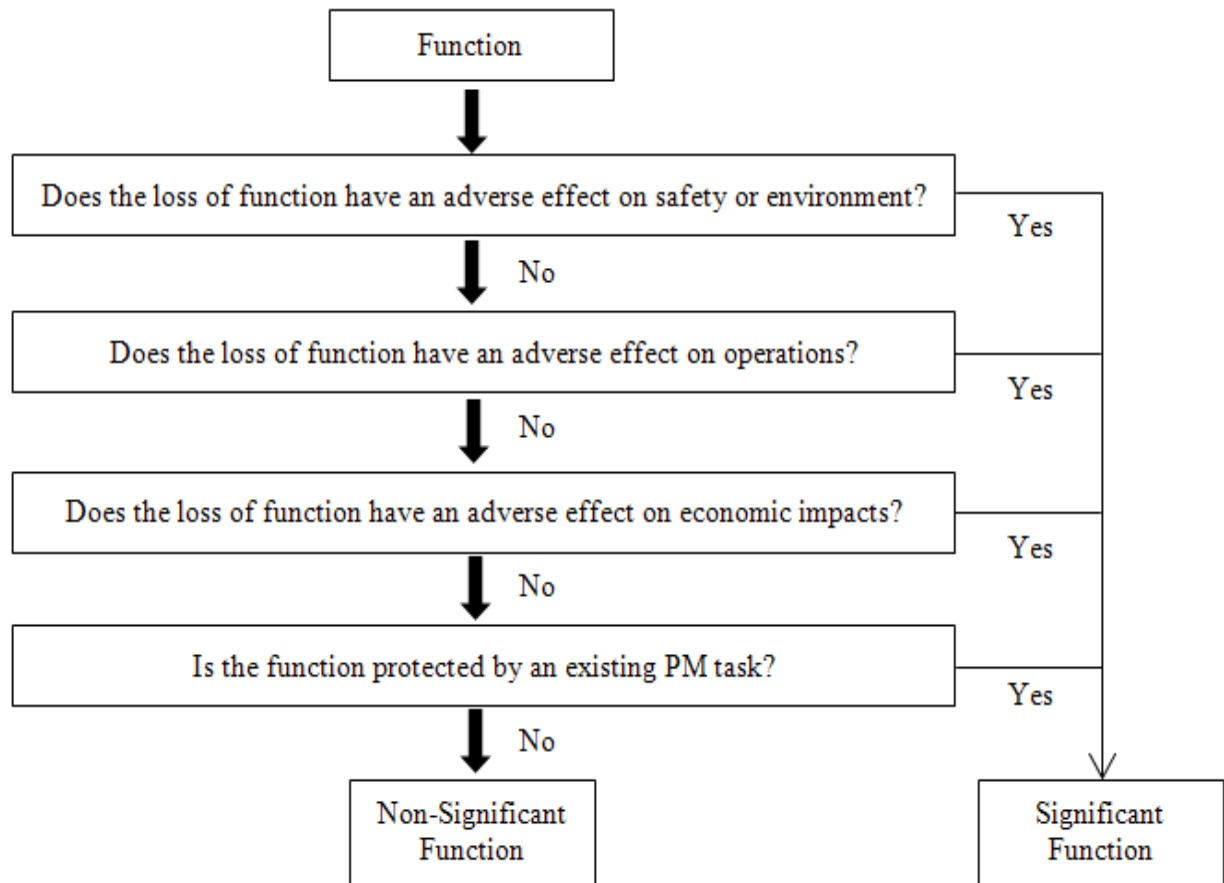

Figure 41. Significant Function Selection Logic Diagram

6.4 Task Evaluation

A 'task decision logic' process must be undertaken using the Decision Logic Diagram (Figure 42), after SFs have been identified. An appropriate failure management strategy is implemented in order to accept, eliminate or decrease the consequences of functional failures. All possible Predictive Maintenance tasks have been studied to cover each functional failure through the Decision Logic Diagram shown in Figure 42.

The study of each functional failure or failure mode effect goes through different branches depending on its circumstances, which finally identifies the suitable options in a two-step process. A failure that is not apparent under normal circumstances is classified as "hidden" because it only appears when a dormant function is activated. Both evident and hidden failures have adverse impacts which require actions, but if for each mode more than one action is possible, an economic and operational impact study is required to identify the best option.

The Decision logic branches identify four types of PM tasks: Lubrication tasks, OC tasks, HT tasks, and FF tasks which have been explained before. Task evaluations are shown for the MV Switchgear and Transformer in Figure 43; evaluating all the failure effects and reporting that the failures on these parts are "evident" for the crew with an economic/operational impact, is what the decision logic shown in Figure 43 can provide, as an example.

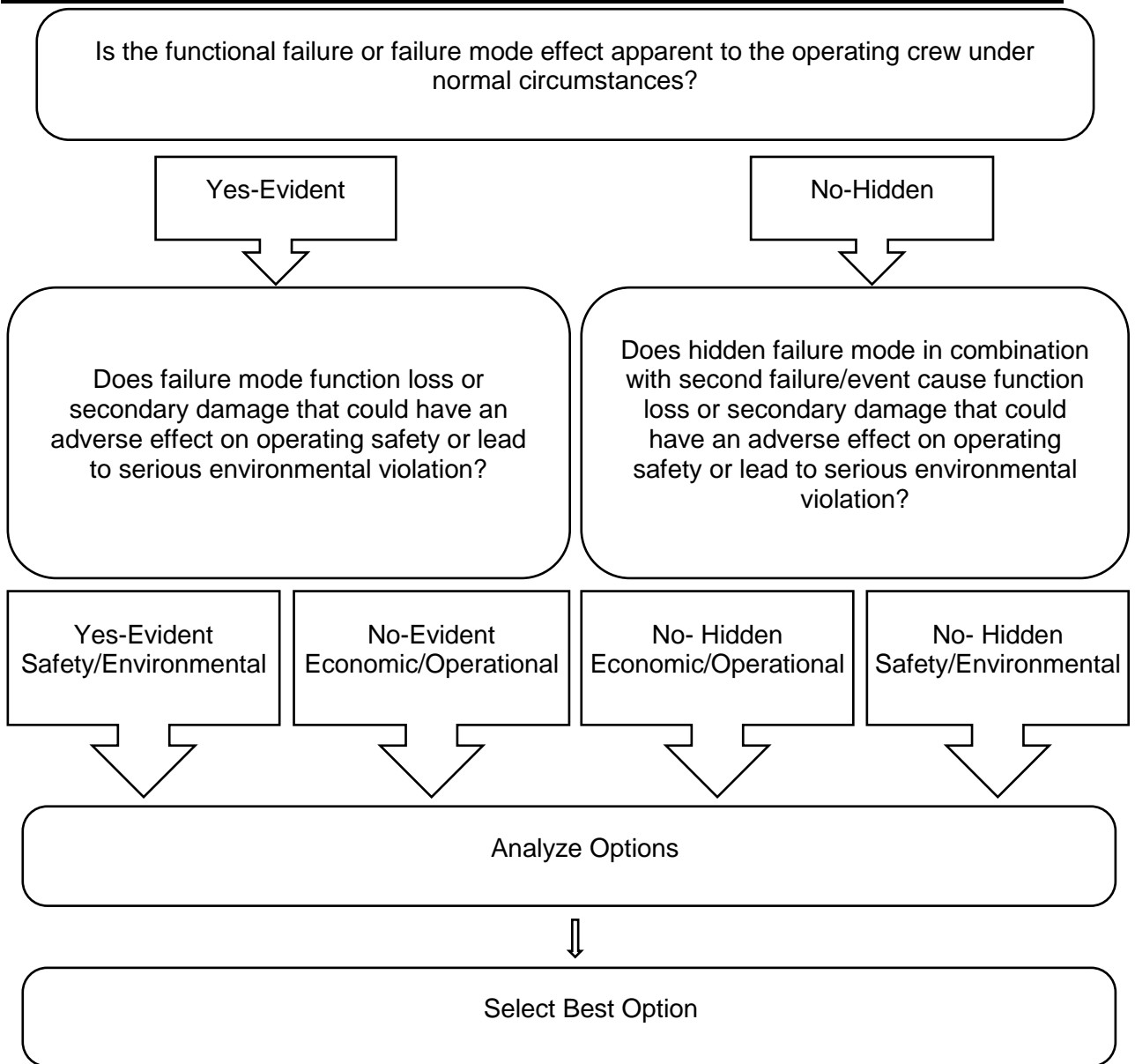

Figure 42. *Decision Logic*

In other words, this is the process in which the best suited task is selected to prevent and deal with each failure mode. If tasks cannot completely prevent the functional failure, the consequences must be reduced until they are acceptable. The available suitable tasks are identified in order to deal with each failure mode through the tasks in the previous sections.

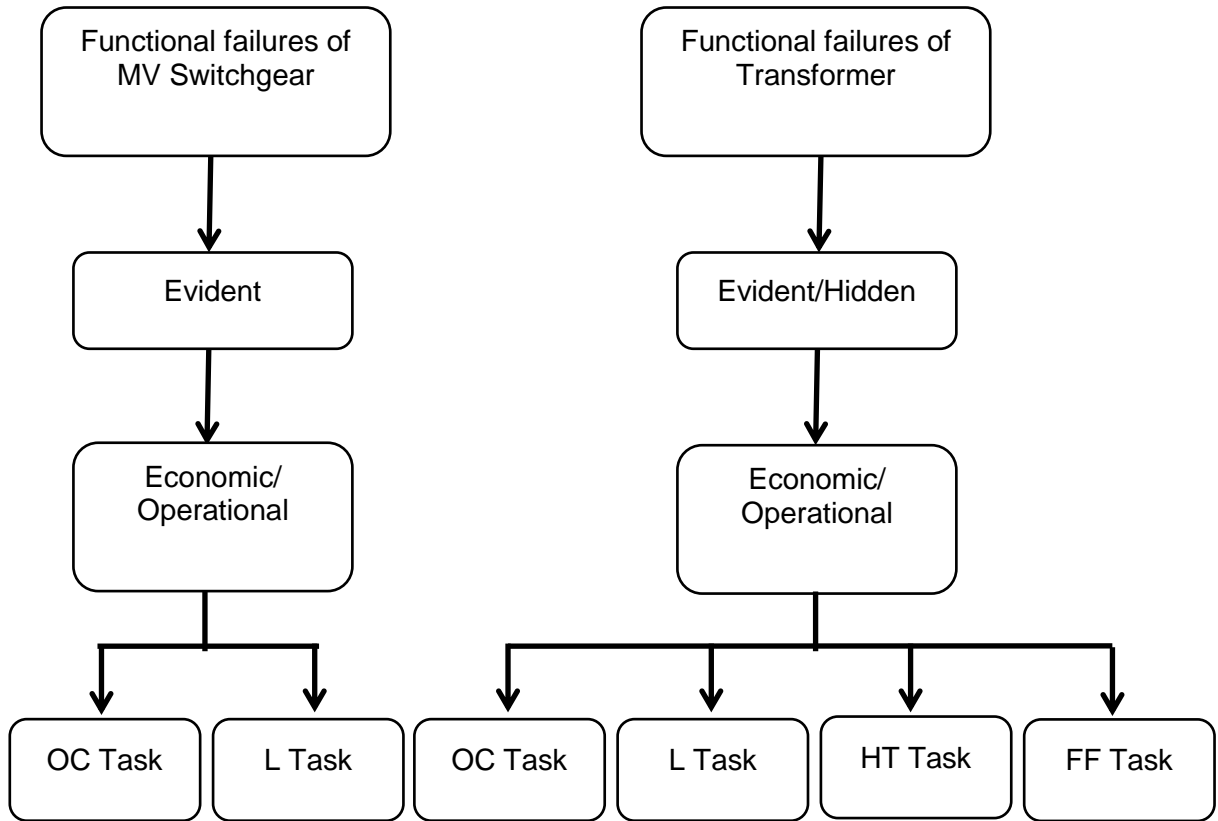

Figure 43. Example of Decision Logic for the MV Switchgear and Transformer

6.5 Task Selection

Once all possible maintenance tasks are known, the following step is the task selection. This evaluation process is done by looking through suitable tasks and taking into account cost analysis and operational consequences, thus determining which one deals better with a given failure mode.

6.5.1 Cost

The cost analysis is based on the cost study which has been done in the Section 5.9.7. Costs are evaluated for each task, including consumables cost, charter cost for the kind of vessel that is used for the preventive tasks, crew cost, energy losses cost and transportation cost. Costs are measured in euros (euros). Two important things that have been taken into account are: the energy losses during activity maintenance and fuel consumptions. All costs have been assumed under a literature review [141], [142], [143], [144], [145], [146]. Eq. (6.1) shows how the overall cost is based on associated costs:

$$C = C_{\text{Consumables}} + C_{\text{Vessel}} + C_{\text{transportation}} + C_{\text{Crew}} + C_{\text{Losses}} \quad 6.1$$

$C_{\text{Consumables}}$ is the cost of the consumables. Assuming that vessels and equipment are needed, costs such as the rental vessel and equipment cost— C_{Vessel} —are also taken into account. $C_{\text{transportation}}$ is the cost based on transportation from the harbor to the wind farm. It is represented by Eq. (6.2):

$$C_{\text{Transportation}} = d \cdot C_1 \quad 6.2$$

- $d = \text{Distance from harbor to wind farm and come back (Km)}$.
- $C_1 = \text{Fuel cost (€ / Km)}$.

C_{Crew} (€): Crew cost is based on Eq. 6.3.

$$C_{\text{Crew}} = t \cdot C_d (t_d + t_0 + t_r) \quad 6.3$$

- $t = \text{Number of technicians}$.
- $C_d = \text{Cost technicians per hour (€ / hours)}$.
- $t_d = \text{Transportation time, round trip (hours)}$.
- $t_0 = \text{Time to adjust the actions (hours)}$. It has been assumed 2 hours.
- $t_r = \text{Time to develop the preventive task (hours)}$.

C_{Losses} (€): Losses of energy have been calculated through Eq. 6.4.

$$C_{\text{Losses}} = (t_r) \cdot C_L \quad 6.4$$

- $C_L = W \cdot E \cdot C_{\text{factor}}$.
- $W = \text{Power Ratio (MW)}$.
- $E = \text{Electricity price = € / MWh}$.

Table 24 shows assumptions about C_{Crew} and C_{Losses} . Other general assumptions have been established as follows:

- The nominal power of the offshore wind turbine is 10 MW.
- A distance from harbor to wind farm of 30 Km.
- Logistic delays have not been taken into account.

The weather window is always perfect to develop the replacement and there is no environmental condition by which to wait in onshore until the maintenance could begin (e.g. wave height).

A Crew Transfer Vessel has been selected in order to carry out the preventive tasks. This vessel is selected for the replacement of items with small and low weight. The role is to transport the crew to the OWT and items of a few tones. Characteristics of the selected vessel are shown in Table 25.

C_d = Technicians Cost (€/hour)	90 €/hour
Electricity Price (€/MWh)	83 €/MWh
Capacity Factor	45%

Table 24. General assumptions

<i>CTV- Crew transfer Vessel</i>	
Fuel Cost, round trip(€)	145.72€
Charter Cost(€)	3.373€
Number of technicians	G1=2; G2=1
t_d = Transportation time, round trip(hours)	1.3
Operational Speed	24 knots
Fuel Consumption	0.24 mt/h (metric ton/hour)

Table 25. Crew Transfer Vessel features

6.5.2 Operational Consequences

The right tasks have to ensure that there are no operational consequences in the OWT. A balance between cost and operational impact should be chosen: a less expensive task will not be selected unless it fits in a work package without operational consequences. As an example, the most suited maintenance tasks associated with each failure mode are shown in Table 26, for several Transformer parts.

<i>Transformer</i>	<i>Maintenance Tasks</i>	<i>Failure Modes</i>
THV	“Use vacuum to remove dirt.”	Oil Insulation Failure; Cooling System Failure, Mechanical damage and faults in insulation.
	“Do an infrared scan and compare it with previous reports. Test temperature. Check ground connections. Check for discolored copper and discolored insulation. Check for carbon tracking on insulators.”	Mechanical damage and faults in insulation; Short circuit, personal safety; Bushings Failure; Tank Failure; Oil Insulation Failure; Possible fire; Winding deformation.
	“Visual check around the transformer area.”	Bushings Failure; Mechanical damage and faults in insulation; Loss of efficiency.
	“Test fans and controls for proper operation.”	Cooling System Failure.
MV Winding & LV Winding	“Carry out ratio test of windings in all tap positions to ensure accuracy according to manufacturer’s data. Compare test data.”	Drift; Mechanical Failure.
	“Remove dirt using vacuum cleaner, blower or compressed air. Clean the areas of contact and tighten bolts and nuts. Apply air dry varnish.”	Mechanical Failure.
Transformer	“Vibration test.”	Increased core temperature.
	“Check diaphragm or bladder for leaks if there is conservator.”	Increased core temperature.
	“Check heat exchangers operation.”	Increased core temperature.
	“Check voltage and adjust it to the most suitable tap.”	Opened; Shorted.
Bushings	“Clean surfaces using brush or wiping with lint free cloth.”	Worn Out.

Table 26. Maintenance task assignment

6.6 Packaging

After selecting the best-suited tasks the next step is to adjust all these tasks in work packages by different criteria in an optimal way. In the first phase of packaging, a proper metric for all the tasks must be selected in order to organize them along the timeline. When converting the metrics of an environmental/safety-related task, special care should be taken, ensuring that the time to perform the task is not exceeded with the new metric. Although the first timeline graph with all the maintenance tasks can suggest a first packaging strategy based on the frequency of the maintenance tasks, the second phase includes other criteria to group the tasks that should also be taken into consideration.

In the second phase, tasks with common characteristics are grouped according to their maintenance level, kind of skills needed, equipment required, task intervals, transportation, etc. While grouping maintenance tasks, the environmental/safety related ones usually set the time for other tasks, due to their less flexible intervals of time which cannot be exceeded.

In the third and last step, the final packaging is developed, introducing other important factors such as the operational impact of the work package (e. g. downtime) or the ability to perform tasks in parallel, managed by previous analysis and engineering criteria. The target, at this point, is to reduce the downtime of the wind turbine as much as possible while maintenance tasks are being performed. The more the maintenance time is reduced, the lesser costs of maintenance; consequently, the availability of the wind turbine, and the energy produced, is also greater. However, factors, such as labour hours (7–9 h and sometimes more) or the reduced spaces to work (limited crew) can make it difficult to obtain optimal packages.

Sometimes tasks do not fit into the established work packages, and may have to be performed as “Special Inspections”. Usually, these inspections have:

- A different kind of vessel: Depending on the component, on which the task is going to be performed, the necessities and equipment needed to access it may be different; consequently, the vessels used will also vary. Usually, three or four kinds of vessels take part in PM programs.
- A different interval: Sometimes, the time to perform a preventive task is very different from the time required for other tasks. This may be due to the item operation, environment requirements, etc. This makes it harder to couple the task to others.

When new tasks or changes on them are being implemented, and they contain the usage of hazardous materials or the emission of contaminant, special authorizations are required. For instance, during the recoating of blades, the use of solvents, certain types of lubricants, and some non-destructive inspection materials may need to be regulated and/or certificated before the task is performed.

In the following example, 59 maintenance tasks from the power module have been packaged. The power module is divided in five parts: Medium Voltage Switchgear (MVS), Generator (GE), Converter (CONV), Transformer (TRANS) and Power Feeder Cables (PFC). The maintenance tasks are numbered as shown in Table 27.

The descriptions of some key tasks are shown in Table 28. In this case, the system is already operating and the intervals are taken from manufacturers' manuals. If the system is in an early design phase, other analyses should be performed to define task intervals. When all the intervals are identified, they are grouped every four months (4 M), six months (6 M), annually (A), two years (2 Y), three years (3 Y), and five years (5 Y) and six years (6 Y). The Table 29 shows the first packaged tasks by their intervals for the Medium Voltage Switchgear and the Generator.

The tasks using common equipment are highlighted with the same colours. In Table 29, the red colour (task number 1) refers to cleaning products and tools for cleaning; the yellow colour (task number 2) means advanced tools for electrical tests; green indicates (task number 3, 10 and 11) basic tools for electrical tests; flesh colour (task number 4 and 17) indicated lubricants; blue colour (task number 12, 15, 18 and 19) depicts temperature and vibration test tools; and purple colour pertains to advanced test tools.

Once the tasks are defined and classified by intervals of time, they have to be arranged in a lifeline. In our case, the tasks have been organized for 6 years (the maximum interval) and distributed over 3 different months with 2 days of work in each one. The simple reason why the workload is distributed in 2 days is because the work package has many working hours that do not fit in the limited labour hours. The months to perform the work packages are chosen based on the best weather periods of the year; the same for applies for the working days in each month, as certain weather conditions must be met. Table 30 shows the distribution of tasks for the first month (March) of work and for the first 6 years. The tasks highlighted in Table 30 are in accordance with the previous ones shown in Table 28 and Table 29 (which follow the criteria previously explained for the packaging). The crew on board the vessel is divided in two teams which work in parallel— thus the time to perform the maintenance tasks is considerably reduced. Table 31 summarizes the working time for each year, for the first month and each work team.

<i>MVS</i>	<i>GE</i>	<i>CONV</i>	<i>TRANS</i>	<i>PFC</i>
1-6	7-25	26-34	35-57	58-59

Table 27. *Maintenance task classification by sub-systems*

Consider the second working day and first work team, with a short working time of 1.8 h. The 1.8 h could have been better packaged with just one work team; however, further analyses for other sub-systems led to other maintenance tasks, that also need to be packaged with the same work team; additionally, there is the possibility that the labour time of the day can be limited to around 8 h.

The Table 32 shows the different cases taken into account when packaging. In the case of October, a more flexible labour time is assumed (where it reaches 11 labour hours)—and so there is only one day of work. However, as it was mentioned before, when the maintenance plan is also performed for the rest of the sub-systems, these times will be readjusted. In the case of July, the two working teams cannot work in parallel because of the limited space in the nacelle; therefore, they are separated in 2 days of work.

<i>Assembly</i>	<i>Sub-Assembly</i>	<i>Task Number</i>	<i>Maintenance Task</i>	<i>Description</i>
MVS	MV Switchgear	1	OC	“Check for accumulations of dirt especially on insulating surfaces. Remove filings. Use suitable cleaners in contacts.”
		2	OC	“Inspect for proper grounding of the equipment. Megger test: insulators to ground, bussing phase to ground, and phase to phase. Test contact resistance across bolted sections of bars.”
		3	OC	“Check electrical operation of: relays, auxiliary contacts, visual indicators, interlocks, cell switches and lighting. Visually inspect arrestors, C/T’s and P/T’s for signs of damage. Check cable and wiring condition, appearance, and terminations.”
		4	L	“Lubricate doors.”
		5	OC	“Inspect insulators and insulating surfaces for cleanliness and cracks. Remove drawout breakers and check drawout equipment. Check condition of bushings for signs of overheating, moisture or other contamination, for proper torque and clearance to ground.”
		6	OC	“Check condition of contacts, connections, starters, and circuit breakers in accordance with test reports and manufacturer’s data. Check physical appearance of doors.”
GE	Stator Windings	12	OC	“Measure temperature at provided measuring points. Measure endwinding vibration.”
	Bearings	15	OC	“Measure and record temperature at provided measuring points. Measure machine vibration. Measure and record condition of bearings using shock-pulse-method. Check bearing seals for oil leakage and clean if dirty. Check for rust.”
	External fans	18	OC	“Visual inspection for rust and dirt. Check the vibration level.”
	Internal fans	19	OC	“Visual inspection for rust and dirt. Check the vibration level.”
TRANS	Cooling System	52	OC	“Clean the cooling air channels. Check the cooling air circulation ducts/openings for proper size and obstructions.”

Table 28. Maintenance task descriptions

INTERVAL	MVS		GE	
	TIME(h)	TASK N°	TIME(h)	TASK N°
4M	3	1,3,6	7.2	7,9,11,12,15
6M			1.8	16,20,24,25
A	2.7	2,5	4.6	8,10,13,14,17,21,22,23
2Y			1	18,19
3Y	0.25	4		
5Y				
6Y				
TOTAL	5.95	6	14.6	19

Table 29. Packaged tasks by intervals for MVS and GE

Year	First Day	Second Day
0	<u>1,3,6</u> ,7,9,11, <u>12,15</u> ,38,49, <u>52</u>	<u>16,20,24,25</u> ,29,33,37,40,41,44,48,54,57,59
1	1,2,3,5,6,7,9,11,12,15,38,49,52	<u>16,20,24,25</u> ,29,33,37,40,41,44,48,54,57,59
2	<u>1,2,3,5,6</u> ,7,9,11, <u>12,15</u> ,18,19,38,49, <u>52</u>	<u>16,20,24,25</u> ,29,33,37,40,41,44,48,54,57,59
3	1,2,3,4,5,6,7,9,11,12,15,38,49,52	<u>16,20,24,25</u> ,29,33,37,40,41,44,48,54,57,59
4	<u>1,2,3,5,6</u> ,7,9,11, <u>12,15</u> ,18,19,38,49, <u>52</u>	<u>16,20,24,25</u> ,29,33,37,40,41,44,48,54,57,59
5	1,2,3,5,6,7,9,11,12,15,38,49,52	<u>16,20,24,25</u> ,29,33,37,40,41,44,48,54,57,59
6	<u>1,2,3,4,5,6</u> ,7,9,11, <u>12,15</u> ,18,19,38,49, <u>52</u>	<u>16,20,24,25</u> ,29,33,37,40,41,44,48,54,57,59

Table 30. Packaged tasks for the first 6 years

<i>First Day</i>	<i>Year 0</i>	<i>Year 1</i>	<i>Year 2</i>	<i>Year 3</i>	<i>Year 4</i>	<i>Year 5</i>	<i>Year 6</i>
Work team 1(hours)	7.2	7.2	8.2	7.2	8.2	7.2	8.2
Work team 2(hours)	4.2	6.9	6.9	7.15	6.9	6.9	7.15
<i>Second Day</i>	<i>Year 0</i>	<i>Year 1</i>	<i>Year 2</i>	<i>Year 3</i>	<i>Year 4</i>	<i>Year 5</i>	<i>Year 6</i>
Work team 1(hours)	1.8	1.8	1.8	1.8	1.8	1.8	1.8
Work team 2(hours)	7.1	7.1	7.1	7.1	7.1	7.1	7.1

Table 31. Working hours for the first 6 years

<i>Year 0</i>	<i>Month</i>	<i>Day</i>	<i>Working team</i>	<i>PM tasks</i>	<i>Hours</i>
	March	Day 1	Group 1	OCx5	7.2
			Group 2	OCx6	4.2
		Day 2	Group 1	OCx4	1.8
			Group 2	OCx10	7.1
	July	Day 1	Group 1	OCx5	7.2
			Group 2	/	/
		Day 2	Group 1	/	/
			Group 2	OCx6	4.2
	October	Day 1	Group 1	OCx12	10.9
			Group 2	OCx13	9.4
		Day 2	Group 1	/	/
			Group 2	/	/

Table 32. Packaging overview for year 0

6.7 Age Exploration (AE)

In the process to elaborate PM programs, assumed data is necessary. An AE updates the data during different analyses.

6.8 Repackaging

In order to improve the work packages there are periodic reviews of:

- Time to perform the task
- Task interval
- Work package interval
- Maintenance process
- Techniques and technologies used

The maintenance documentation from field, which contains the information as previously mentioned, should be reviewed with maintainers to verifying whether the analysis results are realistic.

6.9 Preventive Maintenance applied to other offshore wind turbine systems

The Preventive Maintenance applied to the Power Module, Generator and Transoformer are shown in Table 33, Table 34, Table 35, Table 36, Table 37 and Table 38.

Name	Tagged Part?	Significant Function?	Evident/ Hidden	Safety- Environmental/ Economic-Operational	Maintenance Tasks	Maintenance Tasks	Task Number
POWER MODULE	1						
MV SWITCH GEAR	0						
MV Switchgear	0	S	E	Ope-Eco	OC	Cleaning: Check for accumulations of dirt especially on insulating surfaces and clean interiors of compartments thoroughly using a vacuum or blower. Remove filings caused by burnishing of contacts. Degrease contacts with suitable cleaners.	1
					OC	Electrical Inspections: Megger test insulators to ground. Megger test bussing phase to ground, and phase to phase. Test contact resistance across bolted sections of buss bars. Perform breaker and switch inspection and tests. Inspect for proper grounding of equipment.	2
					OC	Electrical Inspections: Check electrical operation of pilot devices, meters, relays, auxiliary contacts, visual indicators, interlocks, cell switches, cubicle lighting. Visually inspect arrestors, C/T's and P/T's for signs of damage. Check cable and wiring condition, appearance, and terminations.	3
					L	Lubricate doors.	4
					OC	Mechanical Inspections: Inspect insulators and insulating surfaces for cleanliness and cracks. Remove drawout breakers and check drawout equipment. Check condition of bushing for signs of overheating, moisture or other contamination, for proper torque, and for clearance to ground.	5
					OC	Mechanical Inspections: Check mechanical operation of devices. Check condition of contacts. Check disconnects, starters, and circuit breakers in accordance with test reports and manufacturer's procedures. Check physical appearance of doors.	6

Table 33. Preventive Maintenance. Table 1. Part 1

Name	Task Number	Period	Time to perform the task(hours)	Number of Technicians	Resources	MTTF (H)	MTTF (D)	MTTF (M)	MTTF (Y)	MTT PM (Saf)	MTT PM (Ope)	Part Number	Failure Rate, Specified
POWER MODULE						2099	874,9	28,22	2,351	1,175	1,646	WTG80E	47,6225
MV SWITCH GEAR						115180,83	4799,2	154,81	12,901	6,4505	9,030	WTG80EA	8,682
MV Switchgear	1	4M	1,5		Vacuum or blower. Degrease contacts with suitable cleaners.	115180,8	4799,201	154,819	12,9	6,450	9,03	NPRD-87760	8,682
	2	A	2		Megger test; Electrical test								
	3	4M	1		Electrical test								
	4	3Y	0,25		Lubricants								
	5	A	0,7										
	6	4M	0,5										
			4M=3; A=2.7; 3Y=0.25; T=5.95										

Table 34. Preventive Maintenance. Table 2. Part 1

Name	Tagged Part?	Significant Function?	Evident / Hidden	Safety-Environmental/Economic-Operational	Maintenance Tasks	Maintenance Tasks	Task Number
Asynchronous generator					OC	Cleaning: Visual check the degree of dirt deposit inside the generator. Visual check at all accessible points for rust.	7
						Mechanical Inspections: Check tightness of machine foundation bolts and state of locking elements. Check state of alignment of the coupling.	8
	0				HT, OC	Mechanical Inspections: Pay attention to unusual machine noise or change in noise.	9
STATOR	0						
Frame	0	S	E	Ope-Eco	HT		
Stator stack	0	S	E	Ope-Eco	HT		
Stator windings				Ope-Eco	OC	Electrical Inspections: Measure dielectric resistance.	10
				Ope-Eco	OC	Electrical Inspections: Voltage test.	11
	0	S	E	Ope-Eco	OC	Mechanical Inspections: Measure Temperature at provided measuring points. Measure endwinding vibration.	12
					OC	Mechanical Inspections: Check For tightness and state of conductors, terminals and locking elements.	13
Main terminal box	0	S	E	Ope-Eco	OC	Cleaning: Visual check for cleanness and absence of moisture from condensation.	14
ROTOR	0						
Rotor stack	0	S	E	Ope-Eco	HT		
Slip ring	0	S	E	Ope-Eco	HT		
Rotor windings	0	S	E	Ope-Eco	HT		
Shaft	0	S	E	Ope-Eco	HT		
BEARINGS	0						
Bearings							
	0	S	E	Ope-Eco	OC	Mechanical Inspections: Measure and record temperature at measuring points provided. Measure machine vibration. Measure and record condition of bearings using shock-pulse-method. Check bearing seals for oil leakage and clean if dirty. Check for rust.	15

Name	Tagged Part?	Significant Function?	Evident / Hidden	Safety-Environmental/Economic-Operational	Maintenance Tasks	Maintenance Tasks	Task Number
Lubrication system					OC	Mechanical Inspections: Visual inspection.	16
	0	S	E	Ope-Eco	L	Relubricate the bearings, only then the machine is running.	17
Cooling	0						
External fans	0	S	E	Ope-Eco	OC	Mechanical Inspections: Visual inspection for rust and dirt. Check of vibration level.	18
Internal fans	0	S	E	Ope-Eco	OC	Mechanical Inspections: Visual inspection for rust and dirt. Check of vibration level.	19
Heat exchangers	0	S	E	Ope-Eco	OC	Mechanical Inspections: Visual inspection.	20
Filters	0	S	E	Ope-Eco	S	Change filter.	21
AUXILIARY					OC	Electrical Inspection: Check conditions and fastening of all supply cables and connections.	22
	0				OC	Mechanical Inspection: Visual check for cleanness and absence of moisture from condensation.	23
Encoder	0	S	E	Ope-Eco	HT		
Temp sensor	0	S	E	Ope-Eco	HT		
Anti-condensing heater	0	S	E	Ope-Eco	HT, OC	Mechanical Inspections: Visual inspection.	24
Grounding brushes	0	S	E	Ope-Eco	HT, OC	Mechanical Inspections: Visual inspection.	25

Table 35. Preventive Maintenance. Maintenance Tasks. Part 1

Name	Task Number	Period	Time to perform the task(hours)	Number of Technicians	Resources	MTTF (H)	MTTF (D)	MTTF (M)	MTTF (Y)	MTTP M (Saf)	MTTP M (Ope)	Part Number	Failure Rate, Specified
Lubrication system	17	A	0,5		Lubricants	20777062 1,23	8657109 ,22	279261 ,59	23271, 80	11635, 90	16290, 26	WTG80EB C02	
Cooling						924272,51	38511,3 5	1242,3 0	103,53	51,76	72,47	WTG80EB D	1,081932
External fans	18	2Y	0,5		Vibration test	2066837,3 9	86118,2 2	2778,0 1	231,50	115,75	162,05	WTG80EB D01	0,483831
Internal fans	19	2Y	0,5		Vibration test	2066837,3 9	86118,2 2	2778,0 1	231,50	115,75	162,05	WTG80EB D02	0,483831
Heat exchangers	20	6M	0,5			17502406, 58	729266, 94	23524, 74	1960,4 0	980,20	1372,2 8	WTG80EB D03	0,057135
Filters	21	A	0,5			17502406, 58	729266, 94	23524, 74	1960,4 0	980,20	1372,2 8	WTG80EB D04	0,057135
AUXILIARY	22	A	0,4			1662648,6 0	69277,0 2	2234,7 4	186,23	93,11	130,36	WTG80EB E	0,60145
	23	A	0,4										
Encoder						5542162,0 0	230923, 42	7449,1 4	620,76	310,38	434,53	WTG80EB E01	0,180435
Temp sensor						5542162,0 0	230923, 42	7449,1 4	620,76	310,38	434,53	WTG80EB E02	0,180435
Anti-condensing heater	24	6M	0,4			16626485, 99	692770, 25	22347, 43	1862,2 9	931,14	1303,6 0	WTG80EB E03	0,060145
Grounding brushes	25	6M	0,4			5542162,0 0	230923, 42	7449,1 4	620,76	310,38	434,53	WTG80EB E04	0,180435
			4M=7.2; 6M=1.8; A=4.6; 2Y=1; T=14.6										

Table 36. Preventive Maintenance. Details for each Maintenance Tasks. Part1

Name	Tagged Part?	Significant Function?	Evident/Hidden	Safety-Environmental/Economic-Operational	Maintenance Tasks	Maintenance Tasks	Task Number
TRANSFORMER	0						
TRANSFORMER HIGH VOLTAGE					OC	Cleaning: Use vacuum to remove dirt.	35
					OC	Electro-Mechanical Inspections: Do an infrared scan and compare with temperature gage. Test temperature alarms and annunciator points. Check ground connections to proper torque value in accordance with manufacturer's recommendations. Check for discolored copper and discolored insulation. Check for carbon tracking on insulators.	36
					OC	Electrical Inspections: Check area around transformer clear of debris and parts storage.	37
	0				OC	Electrical Inspections: Test fans and controls for proper operation.	38
MV Winding and LV Winding					OC	Electrical Inspections: Carry out ratio test of windings in all tap positions to ensure accuracy to within 0.001 percent. Compare test data to factory test results.	39
	0	S	E	Ope-Eco	OC	Cleaning: Remove accumulations of dirt, giving particular attention to top and bottom of winding assemblies and ventilation ducts using vacuum cleaner and/or blower, or compressed air. Clean the areas of contact and tighten bolts and nuts and apply air dry varnish to nut and bolt assembly.	40
Transformer					OC	Mechanical inspection: Vibration test.	41
						Electro-Mechanical inspection: Check diaphragm or bladder for leaks if there is conservator.	42
						Electro-Mechanical inspection: Check heat exchangers operation.	43
	0	S	E	Ope-Eco	OC	Electro-Mechanical inspection: Check voltage and adjust it to the most suitable tap.	44
Bushings					OC	Cleaning: Clean surfaces using brush or wiping with lint free cloth.	45
	0	S	E	Ope-Eco	HT	Mechanical Inspections: Check bushings with binoculars for cracks and chips.	46
Insulation					OC	Electrical Inspections: Completely isolate transformer to be tested and inspected. Use suitably sized megger to measure resistance.	47
	0	S	E	Ope-Eco	OC	Mechanical Inspections: Check insulators for chips or cracks.	48
Mechanical Structure	0	S	E	Ope-Eco	OC	Mechanical Inspection: Visual Inspection.	49
Core					OC	Electrical Inspection: Megger test using 250 volt megger (or size recommended by manufacturer) between core and ground to ensure no other grounds exist between core and ground.	50
	0	S	H	Ope-Eco	FF		

Name	Tagged Part?	Significant Function?	Evident/Hidden	Safety-Environmental/Economic-Operational	Maintenance Tasks	Maintenance Tasks	Task Number
Cooling System					OC	Mechanical Inspections: IR scan of cooling system. Check for leaks and proper operation.	51
	0	S	E	Ope-Eco	OC	Cleaning: Clean the cooling air channels. Check the cooling air circulation ducts/openings for proper size and obstructions.	52
Tank						Mechanical Inspections: Check oil level. Insulating oil - dissolved gas analysis (DGA).	53
	0	S	E	Ope-Eco	OC	Mechanical Inspections: Check tank for signs of corona deterioration, overheating or carbonization.	54
Oil Insulation	0	S	E	Ope-Eco	OC	Mechanical Inspection: Check for leakage.	55
Diverter Switch					OC	Cleaning: Clean using brush or wiping with lint free cloth.	56
	0	S	E	Ope-Eco	OC	Electro-Mechanical Inspections: Check connections and proper mechanical and electrical operation.	57

Table 37. Preventive Maintenance. Maintenance tasks. Part 2

Name	Task Number	Period	Time to perform the task(hours)	Number of Technicians	Resources	MTTF (H)	MTTF (D)	MTTF (M)	MTTF (Y)	MTTPM (Saf)	MTTPM (Ope)	Part Number	Failure Rate, Specified
TRANSFORMER						1191115,71	49629,82	1600,96	133,41	66,71	93,39	WTG80ED	0,839549
TRANSFORMER HIGH VOLTAGE	35	A	0,5		vacuum	1191115,71	49629,82	1600,96	133,41	66,71	93,39		0,839549
	36	A	1,5		IR SCAN								
	37	6M	0,3		Cleaners								
	38	4M	0,5		Fan test								
MV Winding and LV Winding	39	A	1,5		Ratio test	1191115,71	49629,82	1600,96	133,41	66,71	93,39		0,839549
	40	6M	1		vacuum cleaner and/or blower. air dry varnish								
Transformer	41	6M	1,5		Vibration test	342431,98	14268,00	460,26	38,35	19,18	26,85	WTG80EDF	2,920288
	42	2Y	0,5										
	43	A	0,3										
	44	6M	0,7		Electrical test								
Bushings	45	A	0,4		brush or lint free cloth	0	0	0	0	0	0	WTG80EDF02	0
	46	A	0,5		Binoculars for condition report								
Insulation	47	A	0,6		Megger test	0	0	0	0	0	0		0
	48	6M	1										
Mechanical Structure	49	4M	0,2			0	0	0	0	0	0	WTG80EDF04	0
Core	50	A	0,7		Megger test	0	0	0	0	0	0		0
Cooling System	51	A	0,5		IR SCAN	0	0	0	0	0	0		0
	52	4M	0,5		Brush and material for cleaning								
Tank	53	A	0,3		DGA ANALYSIS	377500,94	15729,21	507,39	42,28	21,14	29,60		
	54	6M	0,2										
Oil Insulation	55	A	0,2			342431,98	14268,00	460,26	38,35	19,18	26,85	WTG80EDF08	2,920288

Name	Task Number	Period	Time to perform the task(hours)	Number of Technicians	Resources	MTTF (H)	MTTF (D)	MTTF (M)	MTTF (Y)	MTTPM (Saf)	MTTPM (Ope)	Part Number	Failure Rate, Specified
Diverter Switch	56	A	0,4		brush or wiping with lint free cloth	342431,98	14268,00	460,26	38,35	19,18	26,85		2,920288
	57	6M	0,5									WTG80EDF09	
			4M=1.2; 6M=5.2; A=7.4; 2Y=0.5; T=14.3										

Table 38. Preventive Maintenance. Details for each maintenance tasks. Part 2

7 Condition Based Maintenance (CBM)

7.1 Introduction

The cost is the most important thing. Maintenance costs are high in an organisation, starting from the spares that need to be kept in the warehouse, maintenance hours and cost mount up. Moreover, the loss of production and the substantial failures to equipment can be the worst maintenance cost due to it could be very high.

Every industry has different objectives in order to keep without failure the equipment. In offshore wind energy sector, wind turbines have to be keep without failures due to the maintenance is very complicate and can cause huge energy losses. These losses could incur in penalties if the energy has to be produced for cities.

Since the detection of the damage before a failure occurs is important, why machines fail must be understand in the first place.

7.1.1 Why machines fail?

Machine failures may come from a lot of sources, starting from the design and end with poor maintenance practices and operating conditions. Influences through the manufactured machine, the installation, the overhaul all contribute to the machine life. The control of these steps may not be had but however an understanding of the potential problems can solve problems.

The aims are to improve the reliability, reducing the maintenance costs and improving the product quality. It can be done improving all steps in the process and everyone involved have to understand the benefits and requirements of precision maintenance.

7.1.2 Common Maintenance practices

Along the time, maintenance practices have been improved. The philosophy had been to run the machine until the failure, dealing with it, fix it and to run once again. When the machine is failed, a spare component is used in order to repair the machines. Nowadays this philosophy is changing and money is invested to change maintenance practices and improving the reliability and therefore saving money. There are a lot of approaches to carry out the maintenance on equipment and it depends on several factors.

7.1.3 Breakdown Maintenance

Breakdown maintenance is also known as corrective maintenance or “fix it when it breaks” and it could drive to high maintenance costs, energy losses, damage of the machine, costs in order to keep spares in the warehouse...etc.

The advantages of this approach over other kind of maintenance are:

- Condition monitoring equipment is not needed.
- Offshore wind turbine will not be over maintained.

7.1.4 Preventive Maintenance Analysis

Preventive maintenance is very useful being one of the most used. It can be known as “calendar based maintenance”. This maintenance is based on the previous studies of reliability, availability and failure modes which are used in order to develop this maintenance plan. It tries to avoid wind turbine failures and extending its life.

The target is to estimate the life of the machine and carry out the overhaul before the failure comes out and therefore there will be a balance between risk and cost. If the maintenance tasks are assigned too short, the machine will not fail but the costs will be higher.

If a graph is plot of the probability of failures of the offshore wind turbine, it can be expected to be like the Figure 44. Along the time, it will get higher probability of failures and therefore this plan is looking to develop maintenance task before that.

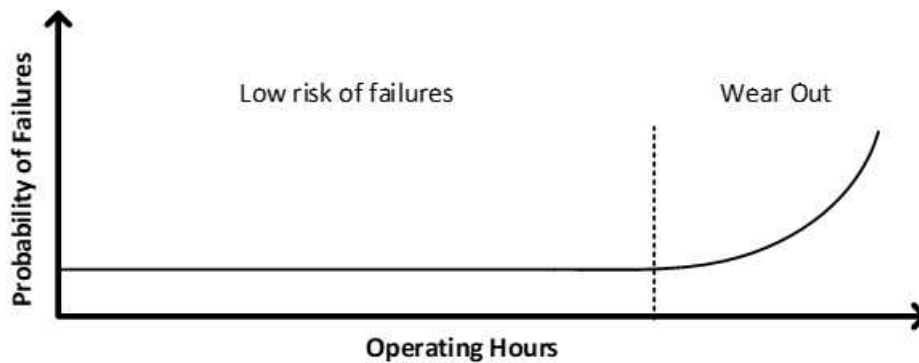

Figure 44. *Estimate probability of failure*

The previous Figure 44 doesn't describe the infant mortality due to several reasons that can suffer components of the wind turbine. The probability of failures is higher at the beginning due to reasons that have been explained before (parts that have been installed incorrectly, poor alignment and balance, etc.). Then the curve could be plotted as:

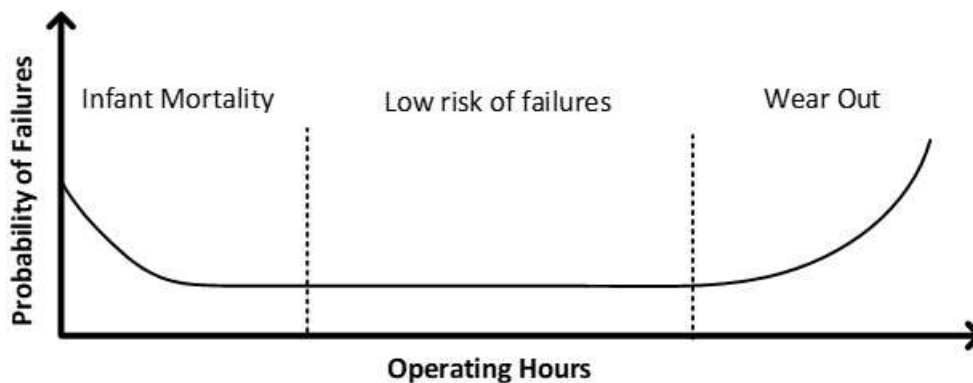

Figure 45. *Bathtub curve*

This new curve is the “bathtub curve” which has been explained in the reliability section. The estimated life against probable life could be different and it is sometimes very difficult to know because the failure of a component is studied but cannot be predicted for sure. Therefore, the maintenance task should be done based on the probable life period.

Maintenance may be scheduled infrequently and hence there will be higher costs, the infant mortality will be higher and higher probability of an unplanned downtime and catastrophic failure.

Previous studies try to find out when the wind turbine fails but it is not completely sure that the wind turbine will fail based on the prediction done. It can be seen in the Figure 46.

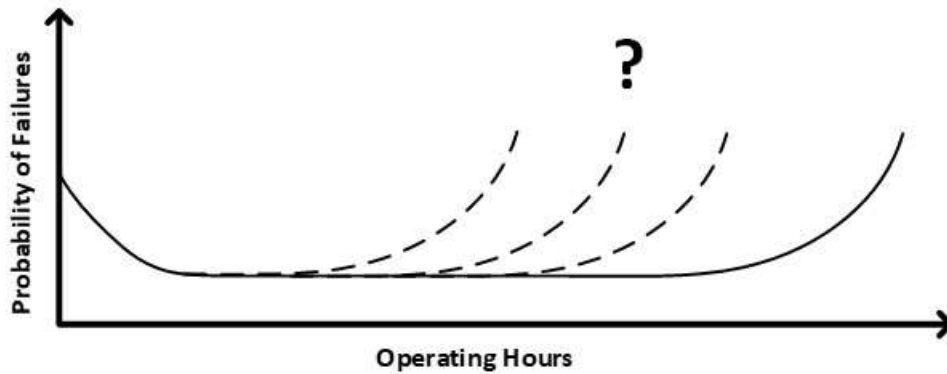

Figure 46. *Probability of failures*

Preventive maintenance has a lot of advantages such as:

- Maintenance task are developed at the right time
- Unexpected failures must be reduced.
- It looks to maximize the production and therefore less energy losses.
- More control under spares and costs

7.1.5 Predictive Maintenance Analysis

It is known as Condition Based Monitoring and the objective is not repair the machines if they are not broken.

All equipment shows indicator of the healthy and it could be measures through sensors. These indicators could come through several ways and depends on the sensors could be known different kind of warning (types of failures).

Condition Monitoring:

The approach of predictive maintenance is to monitor the wind turbine with the appropriate technology in order to detect the anticipated failure. For each part of the wind turbine, a methodology is better than other and therefore it has to be selected carefully.

Monitoring is to observe conditions or features of the system and collect that information. It requires structural analysis, sensors and data acquisition systems, software engineering, etc.

As has been seen in a cost study, the wind turbine blades are the riskiest and most expensive part if blades have to be changed or repair when a failure appears. Then the condition monitoring is applied to the blades looking to know when blades are damaged.

Monitoring structures and in our case wind turbines blades can have impact in:

- Safety
- Design feedback
- Availability
- Economy

Damages could come from bad weather, impacts of birds, alignment, unbalance, ...etc. Then acoustic emission is selected as the approach in order to detect impacts and damage in blades manufactured by composite materials. It will be based on guided waves. The methodology is applied to a composite material panel with stringers and it is considered that the approach can be implemented on blades due to waves has more difficult to go through the composite material panel and therefore the model will work better in real blades.

SHM level are defined as Ritter cited in 1993 and they are the levels which has to be analysed to achieve the final objective:

- Detection
- Location
- Assessment
- Diagnosis coming from the 3 previous levels
- Damage prognosis
- CBM

Then the idea is to develop a **Condition Based Maintenance (CBM)** and the preventive maintenance already explained. The CBM will develop the maintenance based on:

- Usage: It collects information based on the use of the offshore wind turbine. The use defined before the installation can be changed. It means that windiness and stresses can be higher and therefore the offshore win turbine will be under wrong condition and it must be calculated based on that. It is based on the meteorological station of the offshore wind turbine and is covered through the preventive maintenance developed
- Diagnosis. Current state condition of the structure
- Prognosis(SHM): It is the SHM system which find out if the structure has suffered an event (impact) and the structure is damaged. Hence it points out the current usage and the real state condition. It could forecast the schedule tasks based on the future usage.
- Condition Based Maintenance (CBM): If maintenance tasks are needed based on the previous analysis, the maintenance tasks are executed. It is a planned maintenance based on non-destructive techniques.

In the following section 7.3, the prognosis approach (SHM) is explained through a statistical novelty damage detection and location approaches on composite materials. Impacts through several energies are applied to the structure generating several state conditions. Guided lamb waves (GLW) are used with a pitch-catch active configuration, a PZT sensor acts as actuator and the others are listening. The proposed methodology is tested through a frequency swept starting from 50 kHz to 450 kHz, with a step of 100 kHz. A heterogeneous sensor network is employed formed by eight PZT sensors. Signals are pre-processed in order to obtain dominion features that provide information regarding the damage. Damage Index are calculated for each sensor path by statistical metrics finding out the

variation of each signal due to the impact. Damage Indexes (DIs) are compared from the baseline state condition (healthy condition) against a generate damaged state condition. The indicator of damage is warning when the Damage Index are over the threshold (discordant outlier) marked by the baseline state condition. The comparison is done based on statistical time series signals. The damage location is done through the DIs generating a Damage Index grid map in the structure, finding out where has been the structural damage. It achieves a CBM level.

The preventive maintenance is used for a short period of time and after that the maintenance is developed based on the CBM due to it points out if the structure is damaged. Preventive maintenance tasks are based on scheduled time for example servicing and lubrication task and cannot be modified. The CBM improves the reliability, reduces the maintenance cost and reduce the number of maintenance operations.

The SHM applied to rotatory machinery are very used and is very useful. It is based on vibrations and the modes of the rotatory machinery velocity. When they change, it means that a problem has appeared. For this reason, more powerful is not applied to this methodology.

FMECA has pointed out that the riskiest part of the offshore wind turbines are the blades and therefore a structural health monitoring system is studied. It is based on detect events (impacts) and if the impacts or events have generated damaged in the structure. It is explained in the next paper developed in collaboration with Airbus Defence & Space.

An introduction of vibrations applied to rotatory machinery is provided in the section 7.2. The methodology could be applied to the gearbox. The sections describe the principles of the vibrations, what problems can be detected and which are the steps to achieve the failure detection and the pattern of vibration. Moreover, an example of a gearbox is provided.

Then two main components of the offshore wind turbinbe can be monitored and kept without failures through on condition maintenance tasks.

7.2 Vibrations on rotatory machinery for offshore wind turbines

There are six most typical condition monitoring technologies:

1. Acoustic emissions
2. Infrared Thermography
3. Electric Motor Analysis
4. Oil Analysis
5. Wear Particle Analysis
6. Vibrations Analysis

Each one fits better for a damage detection and must be used for a specified aim.

7.2.1 Principles of vibration

For rotating machinery, the vibration is the measure which contains the most information, providing the source of the problem and the severity.

The vibration is the movement of a body from its reference position or the response under an excitation (force). The period, amplitude and the frequency play the most important role in the movement. The period is the time that it takes to complete a cycle. The frequency is based on the number of times something occurs and therefore the frequency is the inverse of the time period.

For the movement, the amplitude of the time signal can be represented through displacement, velocity and acceleration and therefore the same vibration could be displayed in three ways and are directly related to each another

Vibrations are usually analyzed in the time or frequency domain. The time domain depicts the amplitude against the time and the frequency domain displays the amplitude versus frequency. The process to convert the time domain into the frequency domain is the called Fast Fourier Transform (FFT) very well known in the vibration monitoring field. It is shown in the Figure 47.

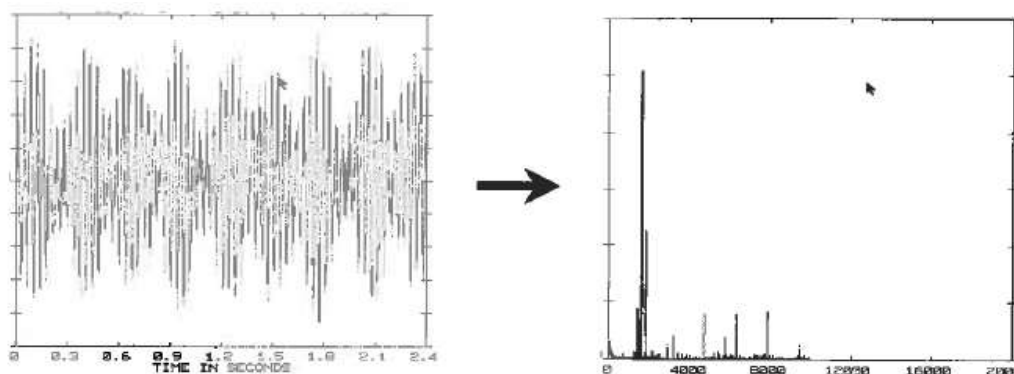

Figure 47. *Example of a time signal converted to frequency domain*

All rotating machinery vibrates. The level of the vibrations and the pattern of these vibrations can indicate the state condition of internal components. Using sensors, this vibration level can be measured and the pattern vibration can be

studied. For example, there is a problem and the level increases and the patterns change, a diagnose of the type of problem is detected. Vibrations analysis can detect a number of problems such as:

- Bearing problems
- Imbalance
- Misalignment
- Looseness
- Soft foot
- Electrical faults
- Eccentric rotors
- Belt and coupling problems
- Gear mesh
- Broken rotor bars

The most typical approach is to locate a special sensor which is sensitive to movement, mounted to a bearing housing. It is collected through a data acquisition system. Then the vibrations signals are studied in order to determine whether a problem exists and the severity of the problem. Data must be collected in more than one location and direction. Normally a machine could vibrate axially. Vertically and horizontally and different failures can be representative only in a way.

There are four main phases into vibration analysis:

1. Detection whether a problem exists
2. Diagnosis the severity
3. To perform a Root Cause Analysis in order to determine why it has happened
4. To verify if the problem is resolved

These 4 phases can be compared against the steps that have been cited into the thesis but more summarized:

1. Diagnosis the problem (detection, locate and assessment of the damage)
2. Prognosis
3. Verify if the problem is solved

7.2.2 Natural frequency and resonance

Natural frequency is the frequency at which a body tends to vibrate under a disturbed excitation. If a force is applied to an object with a frequency equal to the natural frequency, the vibration can be violent and can produce the resonance phenomenon.

7.2.3 Data Acquisition

A data acquisition system able to collect all vibrations data is needed. The most typical used sensor are the transducers which are able to transform the mechanical vibrations into electrical signal which shows the mechanical motion. Accelerometers are usually used and transform the mechanical movement into an analog signal which is proportional to the vibration acceleration. There are more kind of sensors which can be used with a very good result. All sensors exhibit advantages and disadvantages.

7.2.4 Signal Processing

Through the FFT, vibration signals can be displayed through the amplitude versus frequency. The damage detection is done through the peaks that this vibration signal shows. The natural rotation frequency must be seen through these peaks in the signal. More peaks at the multiple of this natural rotation frequency. It means that if the rotation speed is equal to 50rpm, at 100, 150, 200 rpm can be seen a peak in the frequency domain signal. Moreover, there are peaks together which are called harmonics. These harmonics reflect for example gears of a gearbox. Other peaks can be patterns of a problem. These peaks have to be studied meticulously. It is shown in the Figure 48.

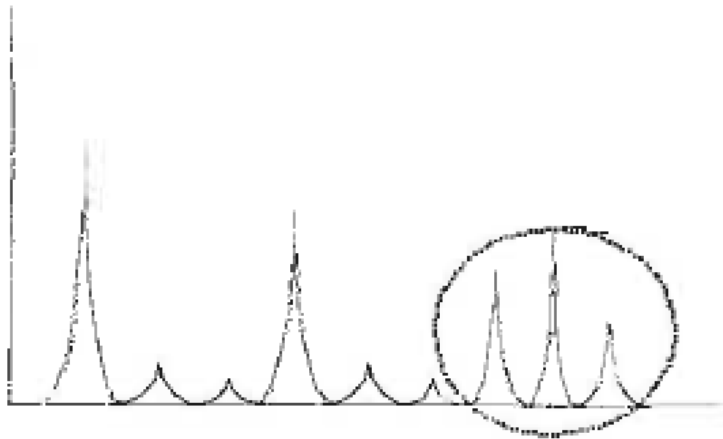

Figure 48. *Peaks and harmonics of frequency domain signal*

7.2.5 Vibrations applied to Gearboxes:

The gearboxes can be analysed under two important points:

- GMF is the product of the number of teeth of a gear and the turning speed.
- Two meshing gears must have the same GMF

It is important due to it must be seen into the frequency domain signals. Most typical problems come from:

- Tooth wear: the sideband frequency (speed of the gear) envelops the gear mesh frequency.
- Misalignment: it is produced because the vibrations arrives to 2xGMF and 3xGMF.

- Chipped tooth: the vibrations arrives to the turning speed of the gear chipped gear
- Tooth load: it is looked depending on the amplitude of the GMF.

A normal gear mesh spectrum of 22 tooth gear can be seen in the Figure 49.

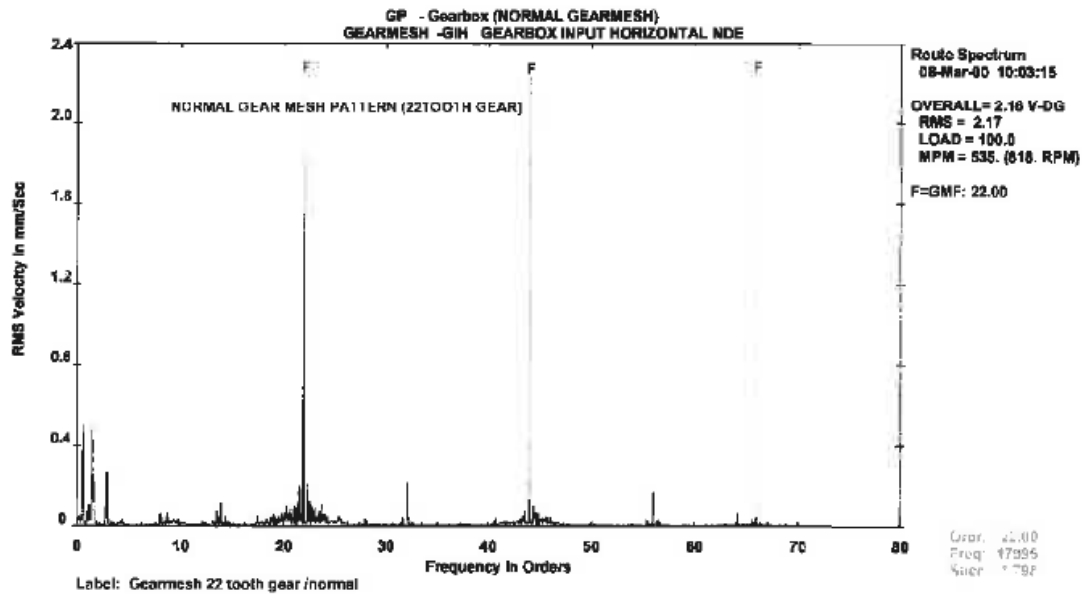

Figure 49. Gear mesh spectrum

7.3 Damage Detection and Location in Composites Materials based on a Novelty Statistical Approach under Post-Impact

7.3.1 Introduction

Aviation provides a lot of opportunities and facilities on people, cultures and is getting a great impact on the world. In 2014, IATA pointed out that airlines spent 62.1\$ billion on MRO (Maintenance, Repair and Overhaul) being 9% of the total operational cost. Moreover, the average maintenance cost per aircraft is 3.64\$ millions. It reflects the wide amount of money lost by maintenance tasks which could be reduced [152]. Then it must be improved, developing the maintenance only when the system needs.

Aircraft health monitoring system constantly working, providing information and warnings regarding faults will help to develop a better planning and scheduling maintenance. Hence through this section, a Structural Health Monitoring (SHM) system is introduced which is able to detect and location of damage in composite materials.

In order to create a SHM system, several levels have to be achieved such as:

1. Operational Evaluation
2. Data acquisition and signal preprocessing
3. Feature damage selection
4. Statistical model development

The operational evaluation has to be done at the beginning due to several aspects of the system has to be analyzed, looking the project viability:

- SHM is performing based on a proper life-safety and economic justification.
- What damages are looked?
- Under what operational and environmental conditions the systems must works.
- Data acquisition can be carried out in a operational offshore wind turbine?

Data acquisition comprises the number of sensor, data acquisition frequency, data acquisition systems, etc. The data pre-processing is all needed task in order to eliminate inadequately signals and to correct them of failures.

The feature damage selection is the methodology that points out which parts of the signal shows if the structure is damaged.

Statistical model development will indicate the state condition of the structure through several steps such as

- Damage detection
- Damage location
- Characterization of the damage
- Assessment of the damage
- Prognosis: how long the system remains operative.

There are three typical failures category:

- Failures due to the component wear
- Predictable events: initial failures can appear due to the incorrect work and it can deteriorate these failures through the time.
- Non-predictable events.

In order to achieve each step, several tests have been carried out. Through this section, points 2 (Data acquisition and signal pre-processing), 3 (Feature damage selection) and 4 (Statistical model development) are analysed and explained.

For the wind turbine blades, damage events are interesting to be monitored during wind turbine operation due to their adverse effect over wind turbine structural integrity and therefore increasing the maintenance cost. The events are defined based on: detection (indication whether there is damage event) and location (position of the damage).

Guided lamb wave is the SHM technique in order to achieve the cited goal. The analysis, evaluation and verification of the SHM technique is performed by experimental testing using different sensor network. The sensor network is formed by piezoelectric sensors.

Impacts through different energies will be applied to this composite material panel and the damage promoted by them is incremented by fatigue cycles in order to achieve an incremental damage growth. This damage growth is considered as an additional event.

7.3.2 Experimental Setup

Activities reported in this paper have been developed in collaboration with Airbus Defense and Space S.A.U. within Clean Sky Green Regional Aircraft Initiative Technology Demonstrator. Sketch of the composite panel used for this aim is shown in the following Figure 50. The panel is made by two frames (F1 and F2) lengthwise and two omega stringers (S1 and S2) crosswise. Then the panel is divided in nine bay areas which can be seen in the Figure 50. Hence it is not an ideal composite material panel which elastic waves can go through it easily.

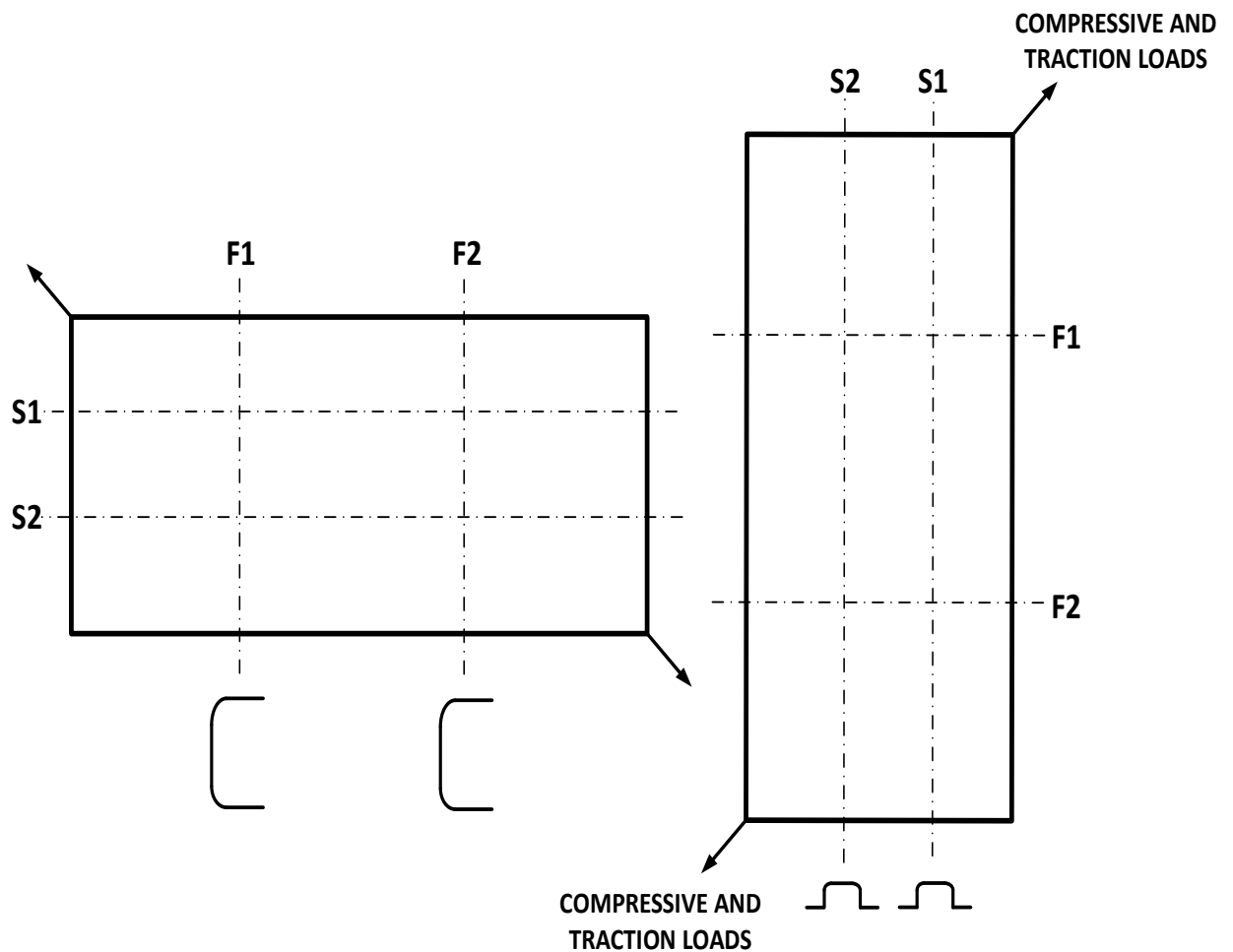

Figure 50. *Composite material panel FLHYB06*

The most common damages in composites material are delamination and debonding of stringers, which can be promoted by impacts. In order to achieve the damage detection and location, a test's task sequence is carried out to the cited composite material panel:

1. Low Energy impacts with gravity impactor (unloaded test panel). The composite panel is located on ground and it is similar to the impact of a mass.
2. Low Energy impacts with compression air impact device. The test panel is installed in the rig in loaded conditions.
3. Fatigue cycling. The test panel is load in order to check the damage growth detection.

The test's tasks sequence of low energy impacts with gravity impactor or compression air impact device both are indicated in the following Table 39. The impacts has been checked by ultrasonic inspections.

TASK ORDER	TASK ID	ENERGY (J)	IMPACTOR	LOAD CONDITIONS
1	Impact I1	5	Gravity	
2	Impact I1	10	Gravity	
3	Impact I2	5	Gravity	
4	Impact I2	10	Gravity	
5	Impact I3	5	Gravity	
6	Impact I3	10	Gravity	
7	Impact I4	5	Gravity	
8	Impact I4	10	Gravity	
9	Traction	N/A	N/A	
10	I1	25	Air Gun	Traction
11	Compression	N/A	N/A	
12	I2	35	Air Gun	Compression
13	Static test	N/A	N/A	
14	FIRST FATIGUE LIFE			
15	Traction	N/A	N/A	
16	I3	35	Air Gun	Traction after the first fatigue life
17	Compression	N/A	N/A	
18	I4	20	Air Gun	Compression after the first fatigue life
19	Static test	N/A	N/A	
20	SECOND FATIGUE LIFE			

Table 39. Low energy impacts and fatigue task's sequence

The composite material panel through the impacts, compressive and traction loads and fatigue cycles generate state conditions which are compared to test the methodology. The different reference and damaged cases state conditions are shown in the following Table 40.

BASELINE CASES	DAMAGED CASES
I1-REF	I1-10J
I1-REF	I1-FC1-025
I1-REF	I1-FC1-075
I1-REF	I1-FC1-100
I1-REF	I1-FC2-050
I1-REF	I1-FC2-100
I1-TRAC-L-REF	I1-TRAC-L
I1-TRAC-UNL-REF	I1-TRAC-UNL
I2-REF	I2-10J
I2-REF	I2-FC1-025

BASELINE CASES	DAMAGED CASES
I2-REF	I2-FC2-025-PW
I2-REF	I2-FC1-075
I2-REF	I2-FC1-100
I2-REF	I2-FC2-050
I2-REF	I2-FC2-100
I2-COMP-L-REF	I2-COMP-L
I2-COMP-UNL-REF	I2-COMP-UNL
I3-REF	I3-10J
I3-REF	I3-FC2-050
I3-REF	I3-FC2-100
I3-TRAC-L-PI-REF	I3-TRAC-L
I3-TRAC-UNL-PI-REF	I3-TRAC-UNL
I4-REF	I4-10J
I4-REF	I4-FC2-050
I4-REF	I4-FC2-100
I4-REF	I4-FC2-100B
I4-COMP-L-REF	I4-COMP-L
I4-COMP-UNL-REF	I4-COMP-UNL

Table 40. Reference and damaged cases state conditions

The test is carried out by 30 piezoelectric sensors, distributed along the test panel. Depending of the impact, 8 PZT sensors are activated. The distribution of sensor and impacts can be seen in the Figure 51.

The brid of used sensors for each impact are detailed in the Table 41.

TASK ID	ACTIVATED SENSORS							
Impact I1	PZT 7	PZT 8	PZT 9	PZT 10	PZT 11	PZT 12	PZT13	PZT 14
Impact I2	PZT 1	PZT 2	PZT 3	PZT 15	PZT 18	PZT 19	PZT 20	PZT 23
Impact I3	PZT 5	PZT6	PZT 12	PZT 24	PZT 25	PZT 26	PZT 29	PZT 30
Impact I4	PZT 11	PZT 13	PZT 22	PZT 24	PZT 27	PZT28	PZT 29	PZT 30

Table 41. Sensors activated for each impact

The novelty of the test is the compression and traction loads, the fatigue cycling applied and the composite panel selected with stringers and omegas, hindering the data analysis. Through the compression loads, traction loads and fatigue cycles the damage growth is looked. Moreover, interest is placed on the behavior of the waves through the omegas and stringers of the panel.

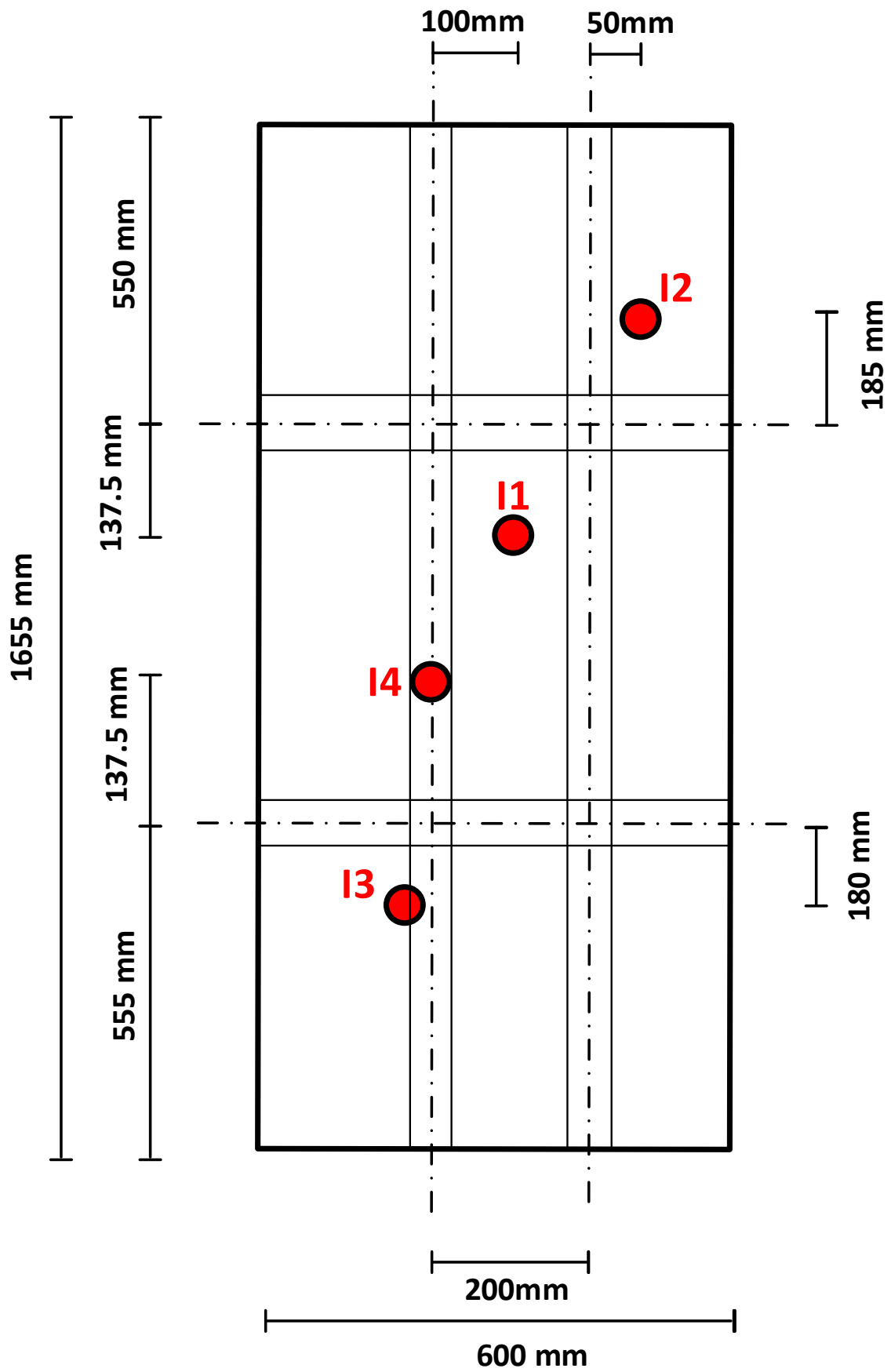

Figure 51. PZT sensors and impacts in the composite panel

7.3.3 Methodology and Results

The methodology is explained through the test, data acquisition system and data analysis.

7.3.3.1 Test methodology

A sequence of task will be developed in order to achieve the SHM levels and to evaluate the methodology applied to this panel.

1. Sensor installation in the composite panel
2. Data acquisition before the impact: “healthy state condition”
3. Gravity or gun air impact to the composite panel
4. Data acquisition after the impact: “damage state condition”

7.3.3.2 Data Acquisition methodology

The sensor network formed by PZT sensors generate a set of raw data files. These raw data files come from the DAQ system. Acellent ScanGenie hardware and software is used to carry out the active approach and this DAQ system generates .dat files. ACESS is the software that provides machine instructions. Finally, these files are treated by Matlab. The Figure 52 shows the steps until the .dat file.

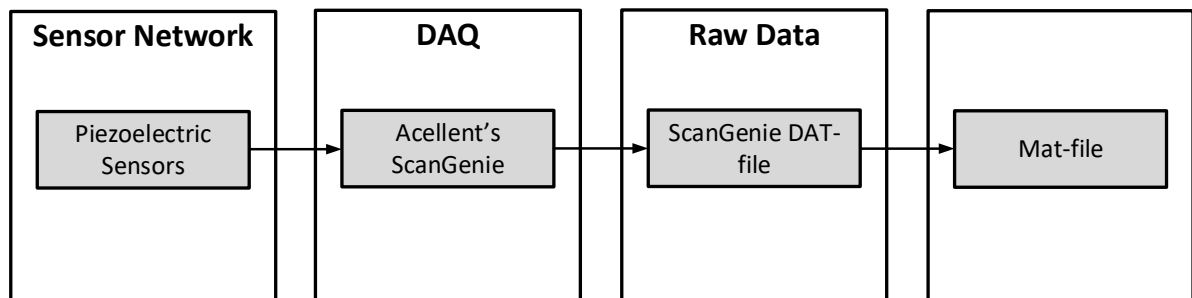

Figure 52. *Flowchart data acquisition system*

In order to achieve that steps, a pitch-catch configuration is used. One piezoelectric sensor acts as an actuator while another one is listening, see Figure 53. The actuator sends through the composite panel an excitation signal with a specific characteristic and this signal is received by the sensor. It is shown in the Figure 53. Through the test methodology steps are generates several cases for different state conditions in the composite panel.

The actuators generate a 3-peak sine burst signal with some characteristic defined. All signals have a sampling rate value equal to $48e^6$ sps. The signal is showed in the Figure 54. It is the most widely signal used due to the great dispersion characteristics and high sensitivity to damage.

The active interrogation has been done through a set of frequencies. The range of frequencies is used in order to achieve the best results and conclusions.

REFERENCE STATE CONDITION

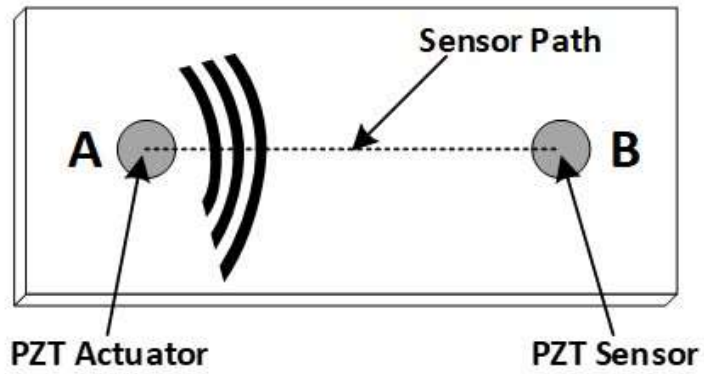

DAMAGE STATE CONDITION

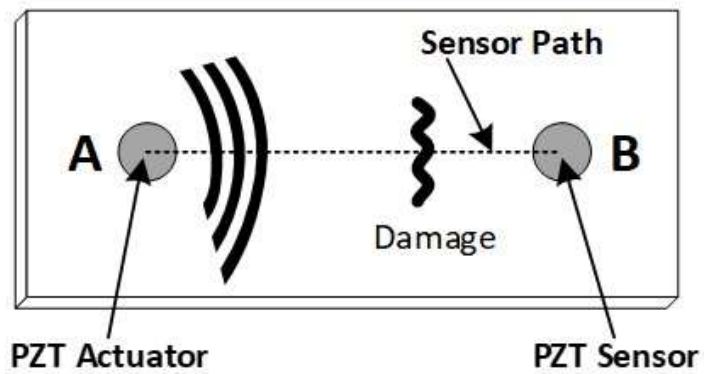

Figure 53. Reference and damage state condition through active approach

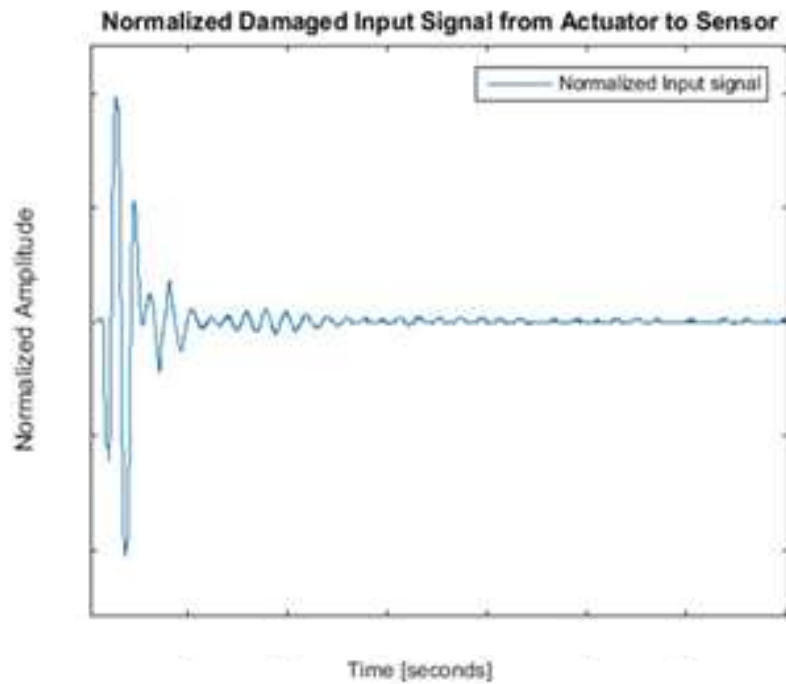

Figure 54. Excitation signal

7.3.3.3 *Analysis methodology*

The goal of the active is carried out through a comparison between signals taken on operating conditions (“damaged structure”) against the healthy reference structure (“baseline structure”). It is done thanks to the Matlab data files generated from the “healthy” and damage state conditions from the previous data acquisition methodology section.

Baselines structure data will form a statistical framework for the healthy structure. If it gets damaged, the value will fall outside that statistics and therefore it is assumed as damaged structure. This is one of the main hypotheses assumed.

The damage analysis has the following levels:

- Data pre-processing
- Damage detection
- Location of the damage
- Characterization of the damage
- Assessment of the damage

The methodology is applied to all shown cases but through this section only are shown results of a damage state condition against its reference.

- I1-REF
- I1-FC2-100

Data Pre-Processing

The technique of PZT active sensor network data processing requires performing the following signal conditioning pre-processing tasks:

- Cross-talk elimination: The cross-talk is an electromagnetic interference between the PZT actuator signal and PZT sensor signal, see Figure 55. It appears in the active interrogation approach. These signals with electromagnetic interferences don't show the damaged raw signals and therefore electromagnetic interferences have to be removed.

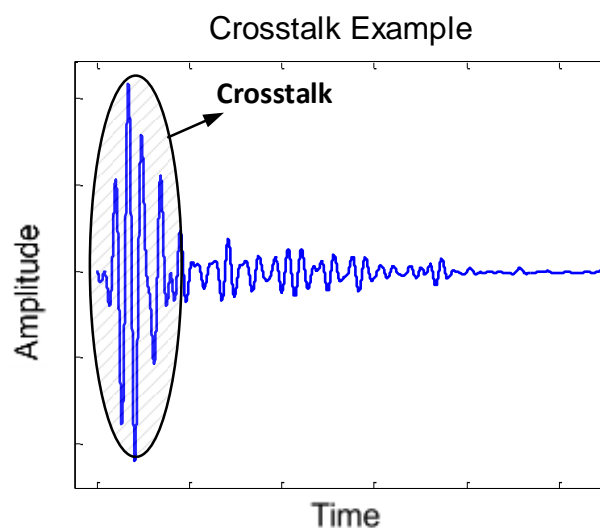

Figure 55. *Crosstalk Example*

- Normalization of signals: When the active interrogation approach is performed, the active interrogation pulse has slightly amplitude values variations. The sine-burst excitation signal must not have a volt gain but it is due to mainly by the derivation to earth point. Then signals are normalized based on limits of the excitation signal between minus one and plus one. Then the normalized sensor signals will have the same energy and can be compared between them. It is shown in the Figure 56.

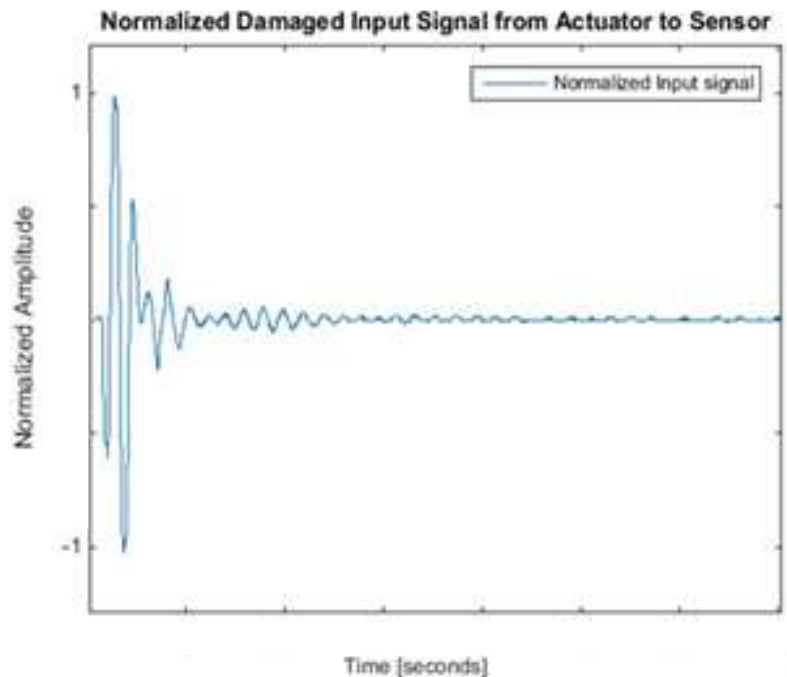

Figure 56. *Input Signal from Actuator from piezoelectric 1 to piezoelectric 2*

Damage Detection

The main aim of the damage detection is to calculate damage indicators (Damage Index) which can proclaim that the structure is damaged. Damage Index are calculated through a called statistical measures and the signal data coming from a PZT sensor network.

The Figure 57 shows an example of undamaged (reference) and damaged signals when the normalization assumptions have been applied and the signal crosstalk is shown. Differences between the signals can be seen quickly due to the damaged impact.

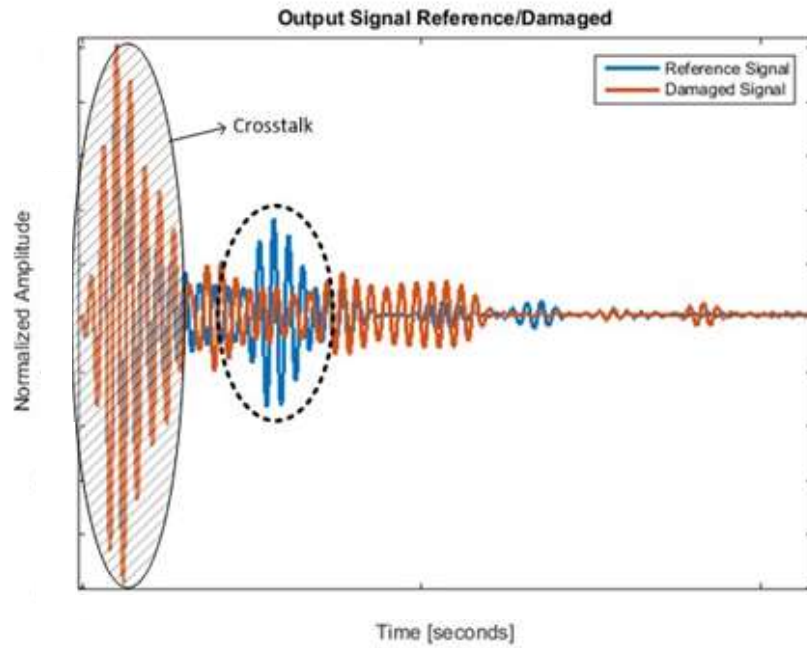

Figure 57. Example of Reference and Damaged Signals

The Damage Index is calculated for each sensor path through a statistical analysis of signals. The deviation of the signal data is calculated due to it reflects if there is damage on the composite material. If the interest zona is analyzed, see Figure 57, the dispersion of data must reflect the damage of the structure. The Eq. (7.1) shows the calculation of DI:

$$Damage\ Index\ (DI) = f(y_{(Undamaged)} - y_{(Damaged)}) \tag{7.1}$$

Where y is the analyzed signal between t_{ini} and t_{fin} depending on the signal.

In order to look the outlier data, signal deviations of each sensor path are analyzed in three cases:

- $DI_{Undamaged-Undamaged}$ (DI_{U-U}): The reference state condition signals are compared individually through comparing signals from both directions in the same sensor paths. It means for the same sensor paths the two ways of signal are analysed, see Figure 58 and Eq. (7.2).

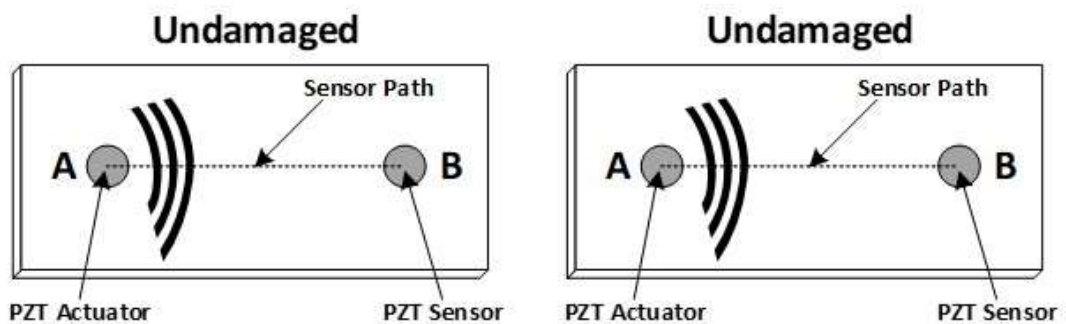

Figure 58. $DI_{Undamaged-Undamaged}$ case

$$DI_{Undamaged-Undamaged} = f(y_{(Undamaged)A-B} - y_{(Undamaged)B-A}) \tag{7.2}$$

- $DI_{\text{Damaged-Damaged}} (DI_{D-D})$: Damaged state condition signals are compared in the same sensor path between signals of both directions. It should show the same results because the same part of the structure is being compared, see Figure 59 and Eq. (7.3).

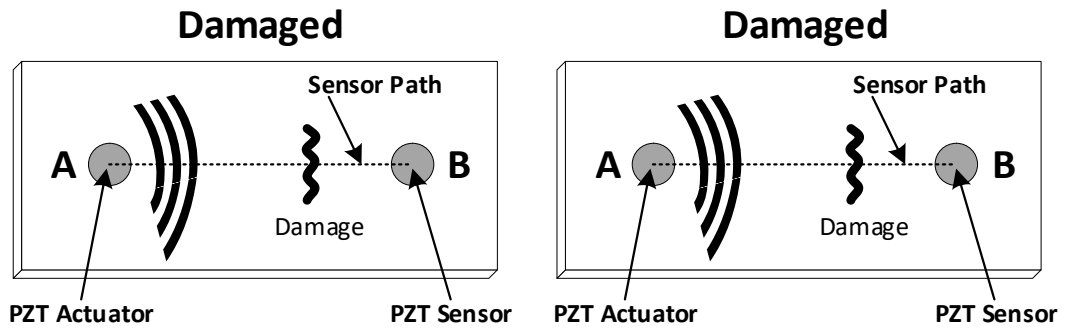

Figure 59. $DI_{\text{Damaged-Damaged}}$ case

$$DI_{\text{Undamaged-Undamaged}} = f(y_{(\text{Damaged})A-B} - y_{(\text{Damaged})B-A}) \quad 7.3$$

- $DI_{\text{Undamaged-Damaged}} (DI_{U-D})$: Reference and damaged state conditions are analyzed through a direction in the sensor path. In that case, discordant outlier data must appear considering that as damage, see Figure 60 and Eq. (7.4).

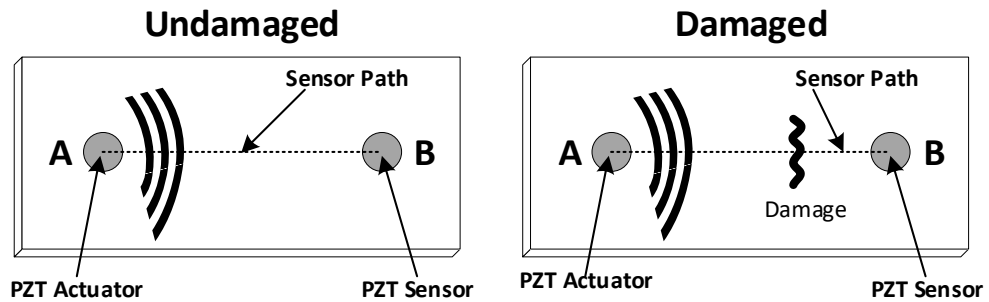

Figure 60. $DI_{\text{Undamaged-Damaged}}$ case

$$DI_{\text{Undamaged-Damaged}} = f(y_{(\text{Undamaged})A-B} - y_{(\text{Damaged})A-B}) \quad 7.4$$

An example for the proposed reference against the damage state condition through the proposed three DI cases can be seen in the Figure 61:

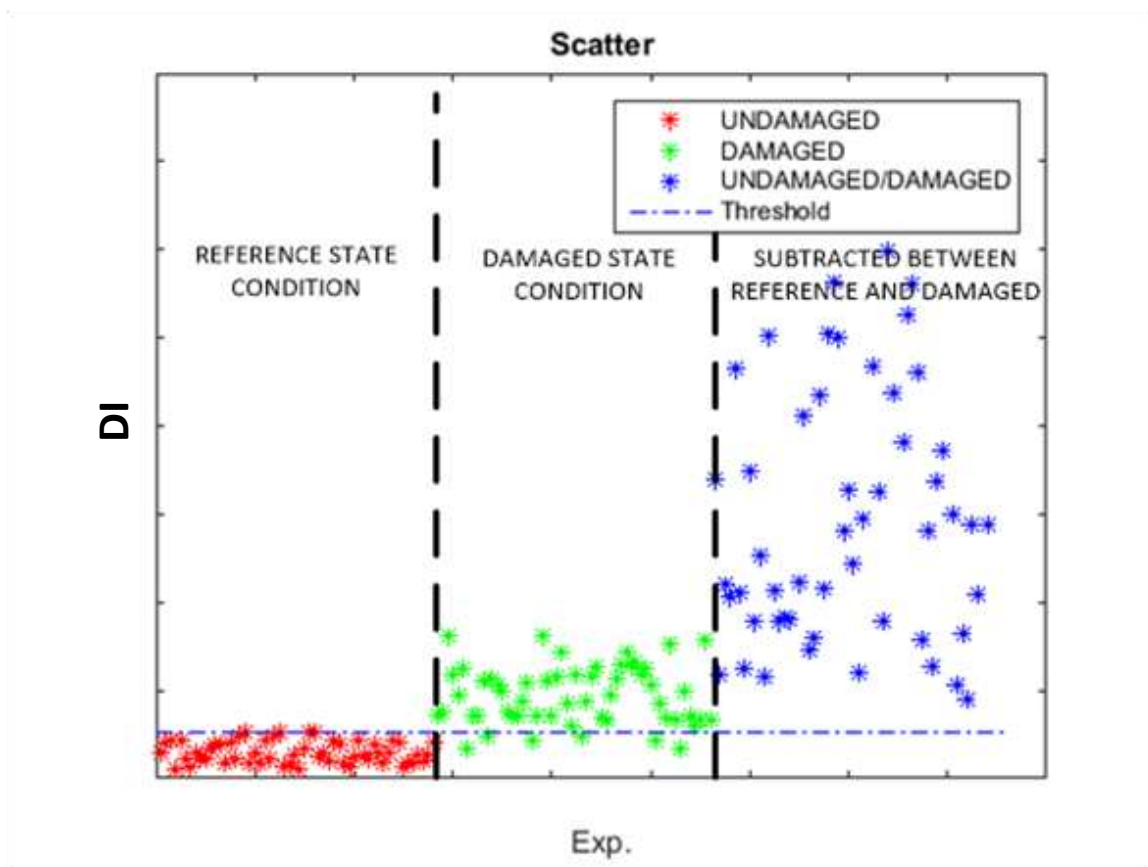

Figure 61. *Damage Index ideal case*

The Figure 61 shows the DI_{U-U} (red points), DI_{D-D} (green points), DI_{U-D} (blue points) calculated by the proposed methodology. The threshold line is calculated based on percentiles. The probability of false alarms is defined as 10% due to errors that can appear. Hence the threshold limit cuts off over the reference data (baseline) at the 90%. This threshold can be seen at the left side of the Figure 61.

Through the frequencies, a lower dispersion of DI is seen and DIs are more compacted when the frequency is getting higher. The difference between the undamaged and the undamaged/damaged data can be seen, pointing out that the DI_{U-D} has higher score and therefore the structure is damaged. The results may help to select the right frequency for the SHM system and to neglect the useless frequencies.

Finally, DI_{U-U} and DI_{D-D} must be very similar due to the same sensor path and the same state conditions is being compared. High differences must appear against DI_{U-D} . It is shown in Eq. (7.5):

$$DI_{U-U} \leq DI_{D-D} \ll DI_{U-D} \quad 7.5$$

The final decision of damage is calculated based upon comparison of DI fitted to distributions. These differences are based on how far DI_{U-D} are outspread against DI_{U-U} and DI_{D-D} . The Figure 62 shows the DI distributions and the differences between these distributions, pointing out the damage in the structure. If

the comparison is false, it means that the two DI distributions are equal and therefore the structure is not damaged.

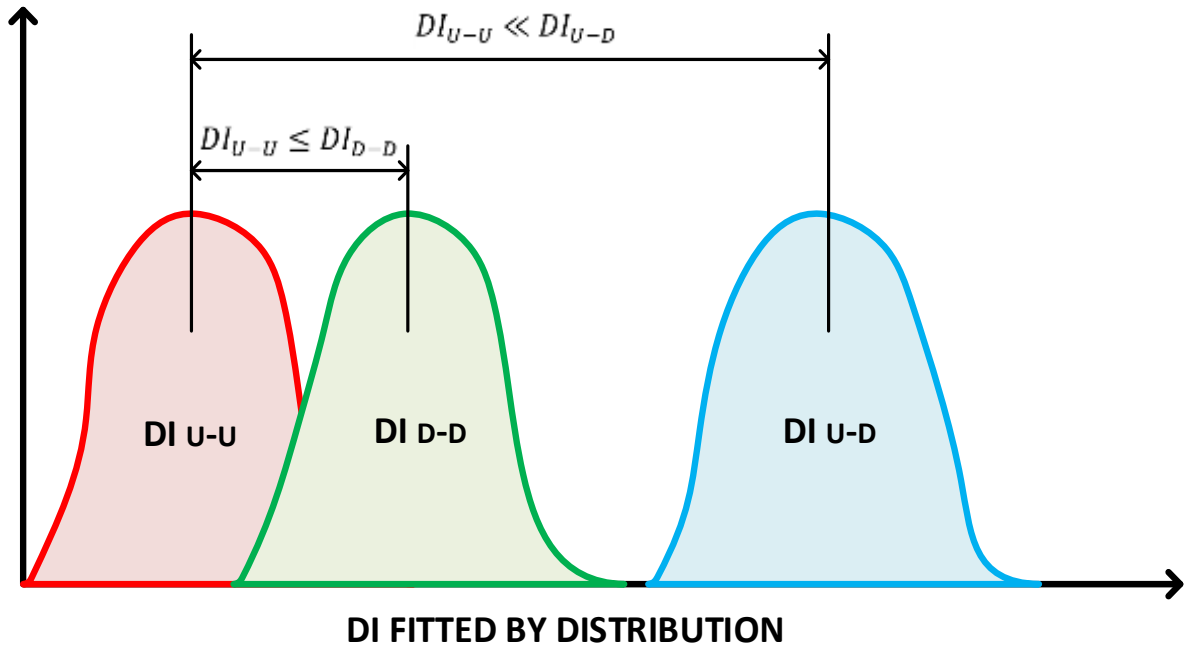

Figure 62. Distribution based on DI

Briefly, all damage state condition results generated are showed in the following Table 42. All tests are studied against them references.

TEST DATA FILES		DETECTION RESULTS (TRUE/FALSE)	
REFERENCE	DAMAGED	INSPECTION	BASIC
I1-REF	I1-10J	Damaged	Damaged
I1-REF	I1-FC1-025	Damaged	Damaged
I1-REF	I1-FC1-075	Damaged	Damaged
I1-REF	I1-FC1-100	Damaged	Damaged
I1-REF	I1-FC2-050	Damaged	Damaged
I1-REF	I1-FC2-100	Damaged	Damaged
I1-TRAC-L-REF	I1-TRAC-L	Damaged	Damaged
I1-TRAC-UNL-REF	I1-TRAC-UNL	Damaged	Damaged
I2-REF	I2-10J	Damaged	Damaged
I2-REF	I2-FC1-025	Damaged	Damaged
I2-REF	I2-FC2-025-PW	Damaged	Damaged
I2-REF	I2-FC1-075	Damaged	Damaged
I2-REF	I2-FC1-100	Damaged	Damaged

TEST DATA FILES		DETECTION RESULTS (TRUE/FALSE)	
REFERENCE	DAMAGED	INSPECTION	BASIC
I2-REF	I2-FC2-050	Damaged	Damaged
I2-REF	I2-FC2-100	Damaged	Damaged
I2-COMP-L-REF	I2-COMP-L	Damaged	Damaged
I2-COMP-UNL-REF	I2-COMP-UNL	Damaged	Damaged
I3-REF	I3-10J	Damaged	Damaged
I3-REF	I3-FC2-050	Damaged	Damaged
I3-REF	I3-FC2-100	Damaged	Damaged
I3-TRAC-L-PI-REF	I3-TRAC-L	Damaged	Damaged
I3-TRAC-UNL-PI-REF	I3-TRAC-UNL	Damaged	Damaged
I4-REF	I4-10J	Damaged	Damaged
I4-REF	I4-FC2-050	Damaged	Damaged
I4-REF	I4-FC2-100	Damaged	Damaged
I4-REF	I4-FC2-100B	Damaged	Damaged
I4-COMP-L-REF	I4-COMP-L	Damaged	Damaged
I4-COMP-UNL-REF	I4-COMP-UNL	Damaged	Damaged

Table 42. *Summary tests of damage detection*

Location

In order to locate the damage, the Damage Index (DI) of each sensor path and frequency is used for that purpose. The DI of each sensor path is known from the previous damage detection section. This DI is a damage characteristic of the sensor path. Then each sensor path can be defined with a damage indicator which is defined with coordinates in both axes generating a grid of points in the structure. It has been done for all sensor paths. It is shown in the Figure 63 and Figure 64.

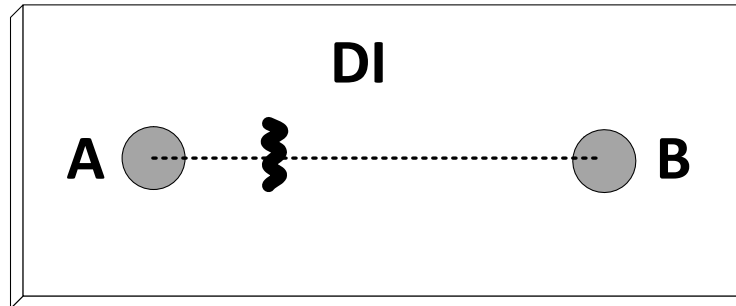

Figure 63. *DI applied to sensor paths*

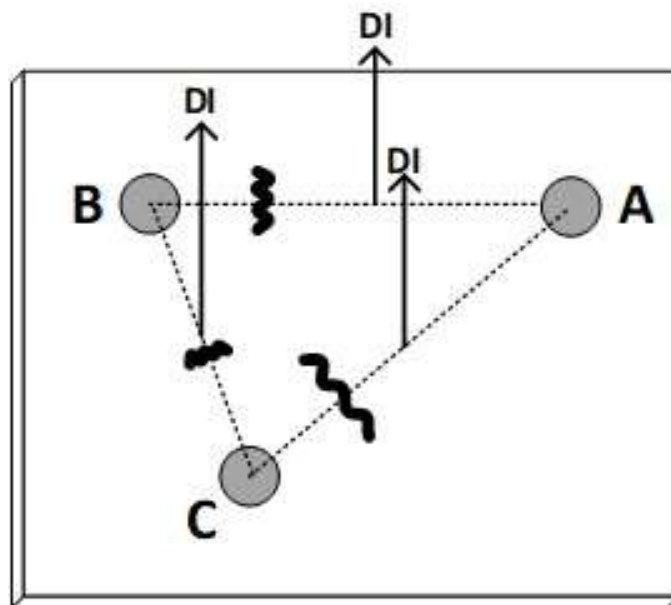

Figure 64. *DI applied to a sensor network*

Damage contours are plotted with the DIs and a surface based on this damage indicator and it provide a location of damage. A DI map based on these DI is shown in the following Figure 65. This methodology is used in order to locate the damage.

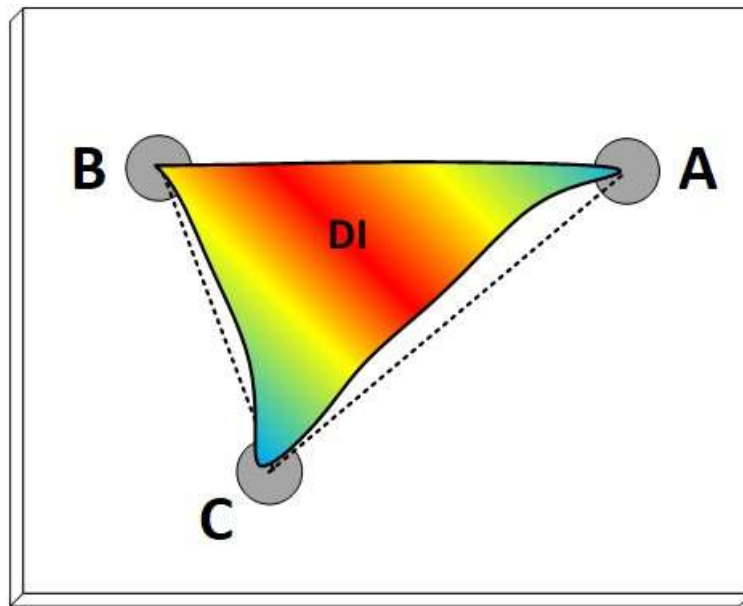

Figure 65. *DI map through the example structure*

An example of the DI surface interpolation is shown in the Figure 66. Through the DI grid map, the damage is located. The nearest interferences have been taken into account, since nearby sensors will generate false alarms of damage.

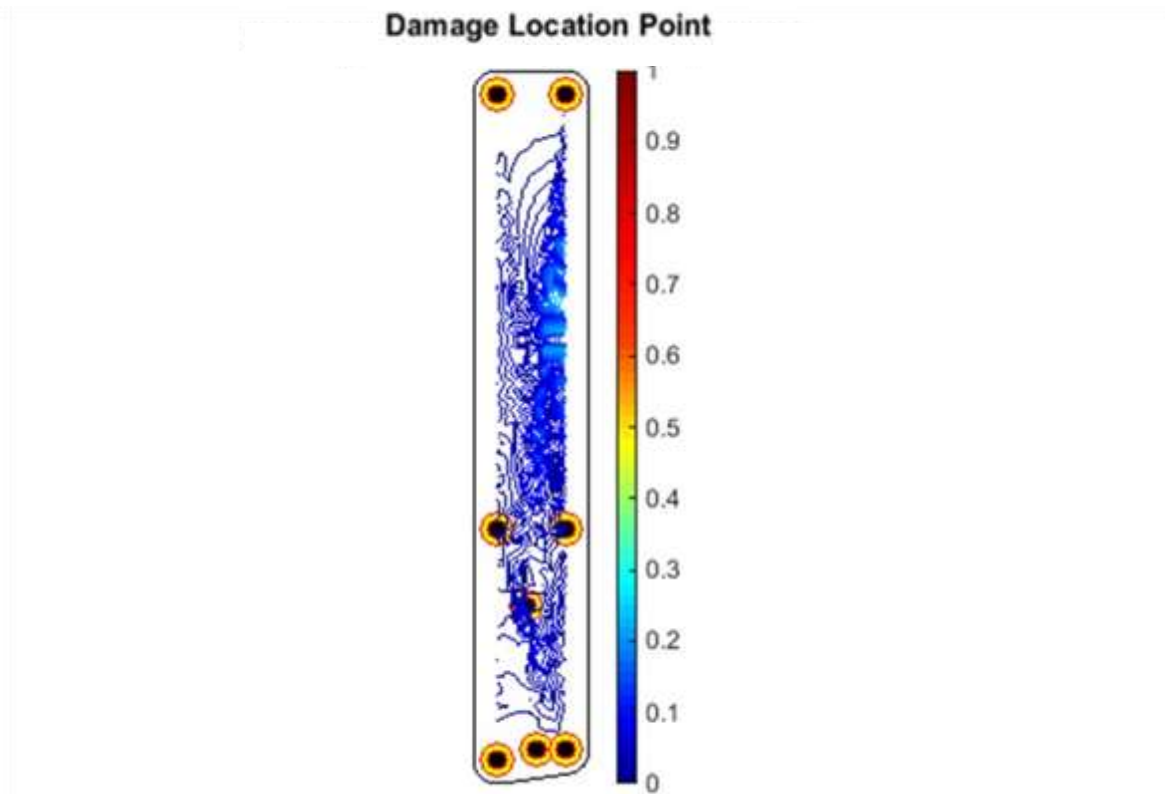

Figure 66. *Damage Location through all frequencies*

It can be used in order to find out the exact point where had been the damage depending on a threshold. The threshold of damage is defined depends on the test scale (currently 15% of the DIs). It means that the test and range of values could change but the location algorithm will select the proper threshold. It gives an

assessment of the location, plotting the points in the structure and finding out the coordinates. Hence a huge amount of highest damage points is created using the set of frequencies. These points are treated and the final location of the damage is calculated based on the most often point.

The final damage point is shown in the following Figure 67. Finally, the predicted versus real damage for other localizations are shown in the Table 43.

DAMAGE NAME	REAL POSITION (*)		DAMAGE LOCATION RESULTS	
	X (mm)	Y(mm)	X (mm)	Y (mm)
I1	300	963	320	906

Table 43. *Impact position*

The average error is 31 mm in X axes and 38 mm in Y axes. These values show that the proposed methodology is feasible. These results are useful for the feasibility purpose and the performance has to be evaluated with lower sensor density looking the desired sparse sensor network.

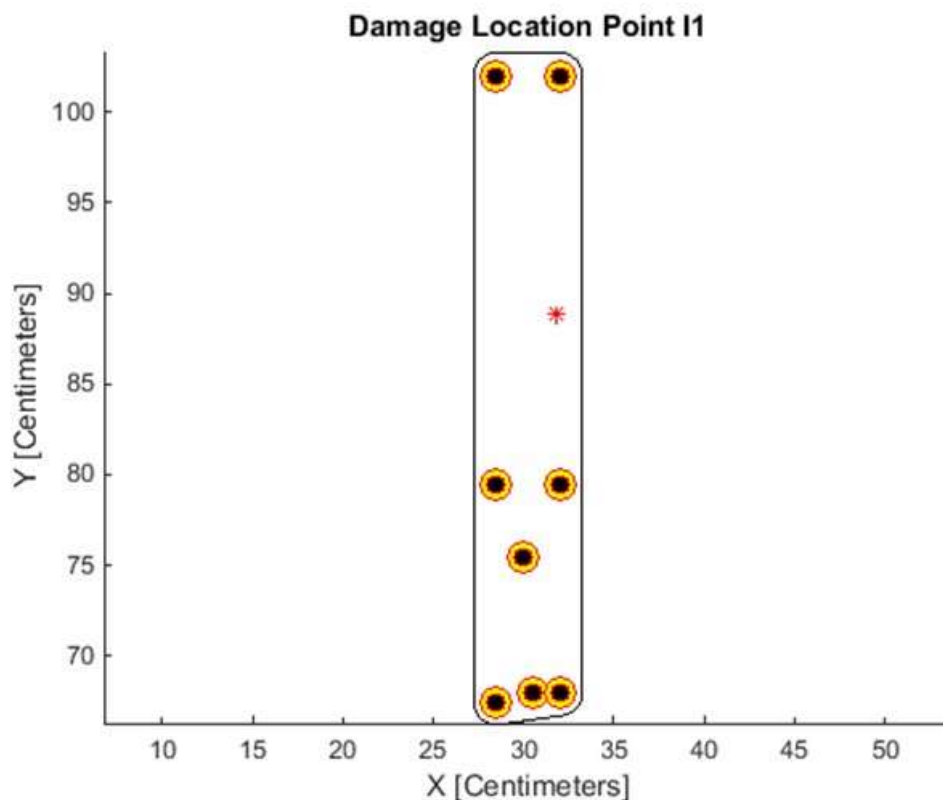

Figure 67. *Damage Point*

Visual assessment is provided in the Figure 68 against the real impact where the sensor layout, real damage and calculated damaged are represented through the analysed panel.

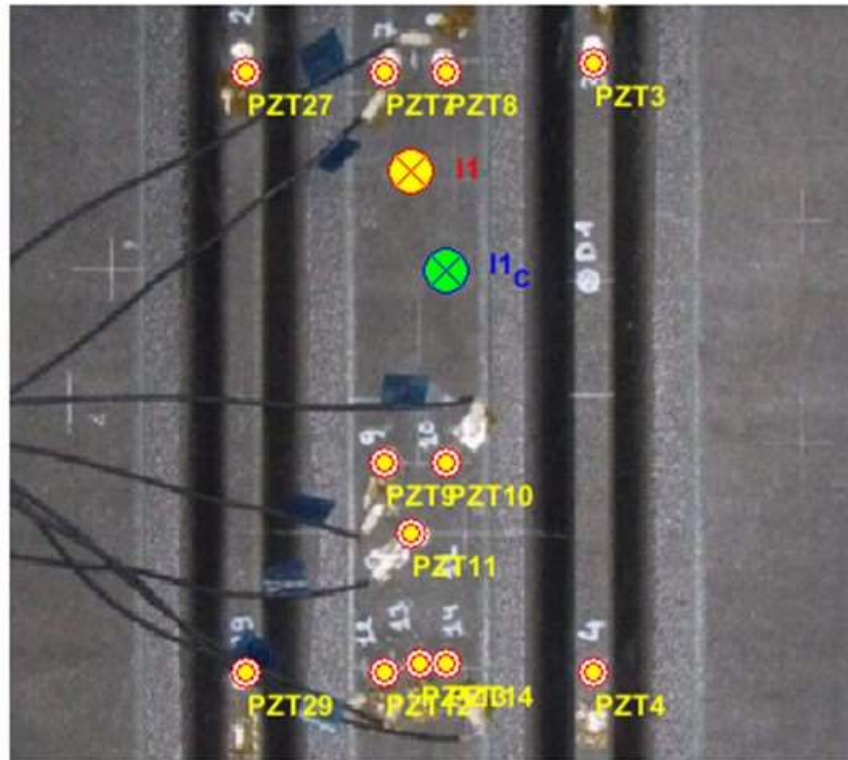

Figure 68. *Damage Location Point*

7.3.4 Conclusions

The proposed methodology can be used for damage detection aims, knowing how is the state of the structure. Damage detection is developed in a non-invasive, inexpensive and reliable way through basic statistical approach. This methodology could provide a template for further tests which can afford quickly if there has been damage in a structure when the comparison is positive between the DI state conditions.

The damage detection aim is achieved better at higher frequencies and the three damage index clusters are more compacted and clearer. It is due to the properties of the composite material. The aerospace structure has acoustic isolation and results may sometimes be confused. This property of the composite material must be taken in account and check how the problem evolves through other tests.

The temperature effects will be studied in further studies. Higher temperatures produce a delay into the piezoelectric signals. This delay is important due to the offshore wind turbine blades will suffer great temperature decreases.

7.3.5 Further Work

Damage characterization (type of damage) and assessment (consequence of the damage). is out of the scope of this paper. It will be evaluated in further studies. The proposed methodology will be applied to other aerospace structures make by composite material. It will be used to test the methodology and to check the reliability of the assumptions.

8 Supportability Software

A Software based on thesis's analysis has been developed. The software is focused on several parts of the thesis as will be described. The software works under specified inputs and therefore it could work in other fields such as: aeronautics, automotive, etc.

The Software has been developed through Matlab and works showing a easily graphic user interface. The software background is done with functions which are called with scripts. The proposed code is elaborated based on methodologies explained in the thesis.

The software looks the following aims:

1. Reliability Analysis
2. Conversion factor analysis from onshore into offshore
3. Life Cycle Analysis
4. FMECA Analysis
5. Maintenance Plans

These tasks developed by the software, are explained deeply in the following sections. A graphical user interface is designed for all analysis. Through this interface, the user could run separately each analysis, specifying the inputs before. The graphical user interface is shown in the following Figure 69.

RELIABILITY & MAINTENANCE SOFTWARE

The software analyse the reliability taken into account the environment of the system, Life Cycle Cost, FMECA and a Maintenance Plan. It could be applied to any system if the inputs are fulfilled.

RELIABILITY ANALYSIS

The Reliability Analysis of a system is developed if the specified inputs are fulfilled
Excel File (Reliability Prediction):

Select path **Run!!!**

Conversion Factor

The Conversion factor analysis of a system is developed if the specified inputs are fulfilled

Input-K1:

Input-K2 if Offshore Environment is selected:

FMECA

The FMECA of a system is developed if the specified inputs are fulfilled
Excel File (FMECA):

Select path **Run!!!**

Life Cycle Analysis

The Lyfe Cycle Analysis of a system is developed if the specified inputs are fulfilled
Excel File (Life Cycle Analysis):

Select path **Run!!!**

MAINTENANCE PLAN

The Maintenance Plan has to be selected between:

Condition Based Maintenance needs the following inputs: Undamaged state condition file, Damaged state condition file and Test Options

Frequency:

The Preventive Maintenance has to be run with a Excel File

Select path **Run!!!**

Figure 69. Grafical user interface of the Matlab Software

8.1 Reliability Analysis

Reliability analysis is carried out for the components introduced in the Excel input. This methodology can be applied to any field as long as the inputs are fulfilment.

Every system is made up by sub-systems, assemblies, sub-assemblies or components. It is specified in the input. The software calculates the failure rate of the sub-assemblies, assemblies, sub-system and system through a bottom up method. The conversion factor analysis is applied to the components which has been indicated in the reliability analysis steps through the input. The quantity, environment of the components, MTTR...etc. has been taken into account.

Reliability Block Diagram is neglected due to it needs the human thoughts and therefore it cannot be elaborated under a programming pattern.

The conversion factor analysis is applied to the components which has been indicated in the reliability analysis steps through the input.

The Matlab code which is supporting the reliability analysis software is shown below:

```
%-----  
-----  
% RELIABILITY_ANALYSIS  
%-----  
-----  
%  
% This function develops the reliability analysis through a excel file  
% input  
%  
%-----  
-----  
% Required functions:  
% none  
%  
% Required functions configuration files:  
% none  
%  
% Required interface:  
% none  
%  
%-----  
-----  
% USE:  
% RELIABILITY_ANALYSIS(excel_filename,conversion_factor)  
%-----  
-----  
% INPUTS:  
% excel_filename: filename of the excel file  
% conversion_factor: conversion factor number  
%-----  
-----  
% OUTPUTS:  
% Reliability Analysis of a system  
%-----  
-----  
% EXAMPLE:  
%  
% failure_rate='PREDICTION WITHOUT FR.xlsx';
```

```

% conversion_factor=1.6;
% RELIABILITY_ANALYSIS(excel_filename,conversion_factor)
%
%-----
----
% $Rev:: 1                                $: Revision of
last commit
% $Author:: Alejandro Sanchez Sanchez      $: Author of
last commit
% $Date:: 2017-10-10                       $: Date of last
commit
%-----
----
function varargout=RELIABILITY_ANALYSIS(varargin)
%% INPUTS
if nargin==2
    failure_rate=varargin{1};
    CONVERSION_FACTOR=varargin{2};
else
    varargout{1}='Wrong number of inputs, only 2 allowed, see help';
    return;
end

%% RELIABILITY PREICTION

% Read the excel file
[fr1,fr2,fr3]= xlsread(failure_rate);

% we takes the names of all metrics
METRICS=fr3(1,:);

% Cells are more useful and then we use fr3
fr3=fr3(2:end,1:end);

%numbers which can points out if the component is assembly,
%sub-assemblie...
assemblies=fr3(:,2);

size_database=length(assemblies);

% Characteristics of the whole Offshore Wind Turbine
OWT=fr3(1,:);
Offshore_Wind_Turbine.OWT=cell2mat(fr3(1,7));

% FR with CONVERSION FACTOR
FR=cell2mat(fr3(:,7));
FR_CONVERISON_FACTOR=FR;
FR_CONVERISON_FACTOR(find(cell2mat(assemblies)==0))=FR(find(cell2mat(assemblies)==0))*CONVERSION_FACTOR;

NAMES=fr3(:,1);
count1=1;

component_FR(:,1)=NAMES;
component_FR(:,2)=assemblies;
component_FR(:,3)=num2cell(FR_CONVERISON_FACTOR);

% CALCULATE FR FOR ALL ASSEMBLIES UNDER COMPONENT FR
[A,B,C]=unique(cell2mat(assemblies));

ind1=find(C==2);

% Separamos todos los sub-system:

```

```

count=1;
for i=2:length(ind1)

    SUB_S=['SUB_SYSTEM_' num2str(count)];
    inx1=ind1(i-1);
    inx2=ind1(i);
    SUB_SYSTEM.(SUB_S)=component_FR(inx1:inx2,:);
    count=count+1;
    if i==length(ind1);
        SUB_S=['SUB_SYSTEM_' num2str(i)];
        inx1=ind1(i);
        inx2=length(component_FR(:,3));
        SUB_SYSTEM.(SUB_S)=component_FR(inx1:inx2,:);
    end
end

sub_system=fieldnames(SUB_SYSTEM);
count2=2;
count3=1;
count4=2;
count5=1;
count6=2;
count7=1;
count8=2;
count9=1;
for j=1:length(sub_system)
    ind2=char(sub_system(j));
    zeros_sub_s=find(cell2mat(SUB_SYSTEM.(ind2)(:,2))==0);
    indicador(1,1)=zeros_sub_s(1);
    for k=1:length(zeros_sub_s)
        if k~=length(zeros_sub_s)
            n=zeros_sub_s(k+1);
        end
        if zeros_sub_s(k)+1~=n
            indicador(count2,1)=zeros_sub_s(k);
            count2=count2+1;
            if k~=length(zeros_sub_s)
                indicador(count2,1)=zeros_sub_s(k+1);
                count2=count2+1;
            end
        end
    end
end
clearvars impar
clearvars par
impar=indicador(1:2:length(indicador));
par=indicador(2:2:length(indicador));

for z=1:length(impar)
    t=par(z);
    ind3=impar(z);
    SUB_SYSTEM.(ind2)(ind3-
1,3)=num2cell(sum(cell2mat(SUB_SYSTEM.(ind2)(ind3:t,3))));
    assemblies_calculados(count3)=ind3-1;
    count3=count3+1;
end
assemblies_calculados=assemblies_calculados';
ASS=['ASSEMBLIES_' num2str(j)];
ASSEMBLIES.(ASS)=SUB_SYSTEM.(ind2)(find(cell2mat(SUB_SYSTEM.(ind2)
(:,2))~=0),:);

[ASS1,ASS2,ASS3]=unique(cell2mat(ASSEMBLIES.(ASS)(:,2)));

unos_assemblies=find(cell2mat(ASSEMBLIES.(ASS)(:,2))==ASS1(end));

```

```

indikator2(1,1)=unos_assemblies(1);
for k=1:length(unos_assemblies)
    if k~=length(unos_assemblies)
        n=unos_assemblies(k+1);
    end
    if unos_assemblies(k)+1~=n
        indikator2(count4,1)=unos_assemblies(k);
        count4=count4+1;
        if k~=length(unos_assemblies)
            indikator2(count4,1)=unos_assemblies(k+1);
            count4=count4+1;
        end
    end
end
clearvars impar;
clearvars par;
impar=indikator2(1:2:length(indikator2));
par=indikator2(2:2:length(indikator2));

if length(impar)~=1 && length(par)~=1

for z=1:length(impar)
    t=par(z);
    ind3=impar(z);
    ASSEMBLIES.(ASS)(ind3-
1,3)=num2cell(sum(cell2mat(ASSEMBLIES.(ASS)(ind3:t,3))));
    sub_assemblies_calculados(count5)=ind3-1;
    count5=count5+1;
end

sub_assemblies_calculados=sub_assemblies_calculados';
ASS2=['SUB_ASSEMBLIES_' num2str(j)];
SUB_ASSEMBLIES.(ASS2)=ASSEMBLIES.(ASS)(find(cell2mat(ASSEMBLIES.(AS
S)(:,2))~=1111),:);

[SA1,SA2,SA3]=unique(cell2mat(SUB_ASSEMBLIES.(ASS2)(:,2)));
unos_unos_assemblies=find(cell2mat(SUB_ASSEMBLIES.(ASS2)(:,2))==SA1
(end));
indikator3(1,1)=unos_unos_assemblies(1);
for k=1:length(unos_unos_assemblies)
    if k~=length(unos_unos_assemblies)
        n=unos_unos_assemblies(k+1);
    end
    if unos_unos_assemblies(k)+1~=n
        indikator3(count6,1)=unos_unos_assemblies(k);
        count6=count6+1;
        if k~=length(unos_unos_assemblies)
            indikator3(count6,1)=unos_unos_assemblies(k+1);
            count6=count6+1;
        end
    end
end
clearvars impar;
clearvars par;
impar=indikator3(1:2:length(indikator3));
par=indikator3(2:2:length(indikator3));

for z=1:length(impar)
    t=par(z);
    ind3=impar(z);
    SUB_ASSEMBLIES.(ASS2)(ind3-
1,3)=num2cell(sum(cell2mat(SUB_ASSEMBLIES.(ASS2)(ind3:t,3))));
    sub_sub_assemblies_calculados(count7)=ind3-1;

```

```

        count7=count7+1;
    end

    sub_sub_assemblies_calculados=sub_sub_assemblies_calculados';
    ASS3=['SUB_SUB_ASSEMBLIES_' num2str(j)];
    SUB_SUB_ASSEMBLIES.(ASS3)=SUB_ASSEMBLIES.(ASS2) (find(cell2mat(SUB_A
SSEMBLIES.(ASS2) (:,2)) ~=111), :);

    [SSA1, SSA2, SSA3]=unique(cell2mat(SUB_SUB_ASSEMBLIES.(ASS3) (:,2)));
    unos_unos_unos_assemblies=find(cell2mat(SUB_SUB_ASSEMBLIES.(ASS3) (:
,2)) ==SSA1(end));
    indicador4(1,1)=unos_unos_unos_assemblies(1);
    for k=1:length(unos_unos_unos_assemblies)
        if k~=length(unos_unos_unos_assemblies)
            n=unos_unos_unos_assemblies(k+1);
        end
        if unos_unos_unos_assemblies(k)+1~=n
            indicador4(count8,1)=unos_unos_unos_assemblies(k);
            count8=count8+1;
            if k~=length(unos_unos_unos_assemblies)
                indicador4(count8,1)=unos_unos_unos_assemblies(k+1);
                count8=count8+1;
            end
        end
    end
    end
    clearvars impar;
    clearvars par;
    impar=indicador4(1:2:length(indicador4));
    par=indicador4(2:2:length(indicador4));

    for z=1:length(impar)
        t=par(z);
        ind3=impar(z);
        SUB_SUB_ASSEMBLIES.(ASS3) (ind3-
1,3)=num2cell(sum(cell2mat(SUB_SUB_ASSEMBLIES.(ASS3) (ind3:t,3))));
        sub_sub_sub_assemblies_calculados(count9)=ind3-1;
        count9=count9+1;
    end
    sub_sub_sub_assemblies_calculados=sub_sub_sub_assemblies_calculados
';
    ASS4=['SUB_SUB_SUB_ASSEMBLIES_' num2str(j)];
    SUB_SUB_SUB_ASSEMBLIES.(ASS4)=SUB_SUB_ASSEMBLIES.(ASS3) (find(cell2m
at(SUB_SUB_ASSEMBLIES.(ASS3) (:,2)) ~=11), :);

    final=['SUB_SYSTEM_' num2str(j)];
    OUTPUTS.(final)=SUB_SUB_SUB_ASSEMBLIES.(ASS4);

    clearvars indicador
    clearvars indicador2;
    clearvars indicador3;
    clearvars indicador4;

    count2=2;
    count3=1;
    count4=2;
    count5=1;
    count6=2;
    count7=1;
    count8=2;
    count9=1;

    else

```

```

clearvars indicador
clearvars indicador2;
clearvars indicador3;
clearvars indicador4;

count2=2;
count3=1;
count4=2;
count5=1;
count6=2;
count7=1;
count8=2;
count9=1;

final=['SUB_SYSTEM_' num2str(j)];
OUTPUTS.(final)=ASSEMBLIES.(ASS);

end

end

salidas=fieldnames(OUTPUTS);
for i=1:length(salidas)
    ind4=char(salidas(i));

    system=['SYSTEM_' num2str(i)];
    OUTPUTS.(system)=OUTPUTS.(ind4)(1,:);

end

%% OUTPUTS
varargout{1}=OUTPUTS;

%% SUBFUNCTIONS AND CALLBACKS

```

All function has been done following several patterns such as:

- The function will be explained at the beginning where a definition, required functions needed, example of function call and outputs.
- Comments in order to follow the functions
- If the number of inputs is not the appropriate, the function throw out a warning.
- The output is saved with a main structure.

The followed methodology has been the same which has been shown in the thesis. Reliability results through Matlab Software are more accurate.

8.2 Conversion factor from onshore into offshore

The conversion factor from onshore into offshore environment analyse the K2 factor depending on different parameter of windiness. The software works under the capacity factor inputs expected by the offshore wind turbine. The software works under any coherent capacity factor value.

The software throws out the percentage of component nominal rating (PCNR) plotted against stress factor in a graph. The final value will be used in order to convert reliability data from onshore into offshore for the reliability analysis step. The use of a function based on the PCNR against K2 facilitate the treatments of data and calculations.

Reliability analysis results can be changed if the capacity factor is modified and therefore the conversion factor is also changed. Then the comparison can reflect how can increase the failure rate in the offshore wind turbine when the capacity factor is modified.

Capacity factor of a wind turbine is the ratio of average delivered power against the theoretical maximum. The design and the geographical location among others affect to the capacity factor. Capacity factor is an important metric when a wind turbine is designed and where is located. Higher capacity factor is coming with higher loads, faster and constant winds, higher stresses, higher fatigue, ...etc. Hence lower reliability must be found out when the capacity factor is higher. A function is calculated based on capacity factor against reliability of the offshore wind turbine. Higher capacity factor doesn't ensure a reduction in the reliability due to along the time the quality of the components and the designs are better.

The capacity factor function can be seen below:

```
%-----
%
%-----
% ASS_CONVERSION_FACTOR
%-----
%
%
% This function develops the conversion factor analysis in order to be
% applied to the reliability analysis.
%
%-----
%
% Required functions:
%     none
%
% Required functions configuration files:
%     none
%
% Required interface:
%     none
%
%-----
%
% USE:
%     ASS_CONVERSION_FACTOR(S,options)
%-----
%
% INPUTS:
%     capacity_factor_1:  it will calculate the K1 factor
%     capacity_factor_2:  it will calculate the k2 factor
%-----
%
% OUTPUTS:
%     Capacity factor calculated based on the system environment
%-----
%
% EXAMPLE:
```

```

%
% S=Data Structure with ref_data and damaged_data.....;
% options.fin=32000;
% options.used_sensors=[1 2 3 4 5 6 7 8];
% options.used_frequencies=[50000 150000 250000 350000 450000];
% options.N_burst=3;
% options.SRate=48000000;
% SHM_DAMAGE_DETECTION_DamageIndex(S,options)
%
%-----
----
% $Rev:: 1                                $: Revision of
last commit
% $Author:: Alejandro Sanchez Sanchez      $: Author of
last commit
% $Date:: 2017-10-10                       $: Date of last
commit
%-----
----
function varargout=ASS_CONVERSION_FACTOR(varargin)
%% INPUTS
if nargin==2
    conversion_factor_1=varargin{1};
    conversion_factor_2=varargin{2};
else
    varargout{1}='Wrong number of inputs, only 2 allowed, see help';
    return;
end
%% CONVERSION FACTOR-K1

if conversion_factor_1=='Offshore_environment';
    OUTPUTS.K1_naval_sheltered=1.5;
    OUTPUTS.K1_naval_exposed=2;

elseif conversion_factor_1=='Vibration_free'
    OUTPUTS.K1=0.5;

elseif conversion_factor_1=='Ground_based'
    OUTPUTS.K1=1;

elseif conversion_factor_1=='Road'
    OUTPUTS.K1=3;

elseif conversion_factor_1=='Rail'
    OUTPUTS.K1=4;

elseif conversion_factor_1=='Air'
    OUTPUTS.K1=10;

elseif conversion_factor_1=='Missile'
    OUTPUTS.K1=100;

end

%% CONVERSION FACTOR-K2
% load the graph for K2 factor

PCNR=[20;40;60;80;100;120;140];
K2=[0.1;0.2;0.3;0.6;1;2;4];

p=polyfit(PCNR,K2,4);

axes_PCNR=10:10:150;

```

```

y=polyval(p, axes_PCNR);

figure
plot(axes_PCNR,y, 'linewidth',2)
title('CONVERSION FACTOR', 'FontSize', 20, 'fontweight', 'bold')
ylabel('K2', 'FontSize', 16, 'fontweight', 'bold')
xlabel('PCNR', 'FontSize', 16, 'fontweight', 'bold')
% get(gca, 'FontSize',16)

% K2 Output from the PCNR input
input_PCNR=conversion_factor_2-25+100;
OUTPUTS.K2=polyval(p, input_PCNR);

%%
if conversion_factor_1=='Offshore_environment';
    OUTPUTS.CONVERSION_FACTOR_naval_sheltered=OUTPUTS.K2*OUTPUTS.K1_naval_sheltered;
    OUTPUTS.CONVERSION_FACTOR_naval_exposed=OUTPUTS.K2*OUTPUTS.K1_naval_exposed;
else
    OUTPUTS.CONVERSION_FACTOR=OUTPUTS.K1*OUTPUTS.K2;
end
%% OUTPUTS
varargout{1}=OUTPUTS;

%% SUBFUNCTIONS AND CALLBACKS

```

The followed structure of the function has been done with the same judgements which has been explained for Reliability Analysis case.

Conversion factor software throws out the conversion factor function for the K2 factor Figure 70.

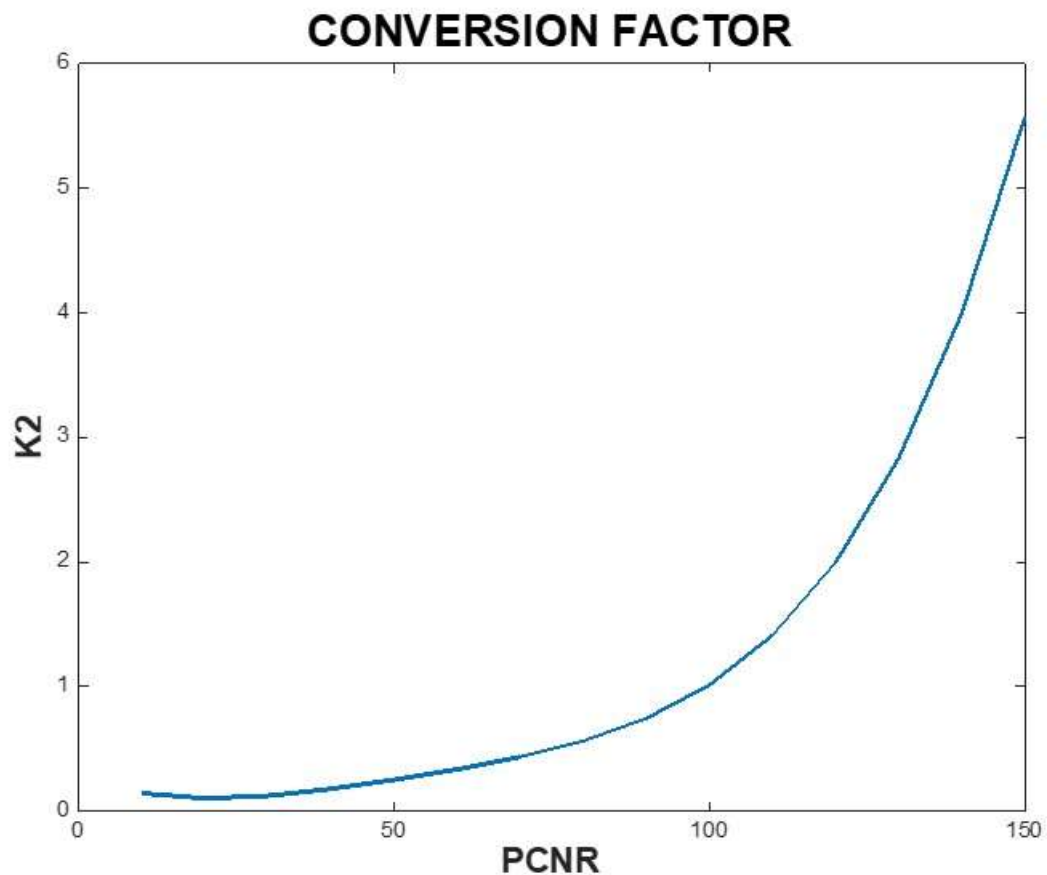

Figure 70. Conversion factor function, K2 againsts PCNR

8.3 FMECA Analysis

A large number of components is used to develop the FMECA. Sub-systems, assemblies, sub-assemblies, components and so on, generate a mesh of elements. It sometimes is difficult to follow the failure mode starting from the component arriving to the system. Then with the FMECA software want to be shown a hierarchical cluster of the failure modes at the component level and how to arrive to the system level. The inputs have to be fulfilled for the success of the results.

8.4 Life Cycle Analysis

Life Cycle cost is based on a deeply cost study of each part of the wind turbine. As other software parts can be used for other systems, this Life Cycle Analysis can only be done for the offshore wind turbines parts. Costs are based on offshore environment and are calculated based on that. Costs taken into account are:

- Initial costs such as purchase of the components and construction
- Fuel cost
- O&M and repair costs
- When an item fails, the costs of replacement this component
- Residual value
- Financial charges when the investment is carried out.

A sub-system of the wind turbine has to be selected through the Excel file and this sub-system is analysed through all aspects already cited.

8.5 Maintenance Plans

The graphic user interface shows two possible maintenance plan options. On the one hand, the preventive maintenance can be selected and all maintenance plan is shown. Moreover, an optimization of the scheduled maintenance task is done against the O&P cost. This optimization helps to fit better the scheduled maintenance tasks. The Preventive Maintenance explained approach is shown through the graph.

On the other hand, the Condition Based Maintenance can be activated. This maintenance shows the methodology of the displayed test. The reliability of the methodology can be check through the damage location. It is thinking to be implemented in the offshore wind turbine through a sparse PZT sensor network which could achieve damage impacts and the location of the damage. Parameters as frequency, impact, sensors used are options which the user can select.

The code can not be shown in order to keep the confidentiality of the data.

Through the Maintenance Plan software, several examples of the CBM can be studied. An example of the I4 impact damage location of the test is shown in the following Figure 71.

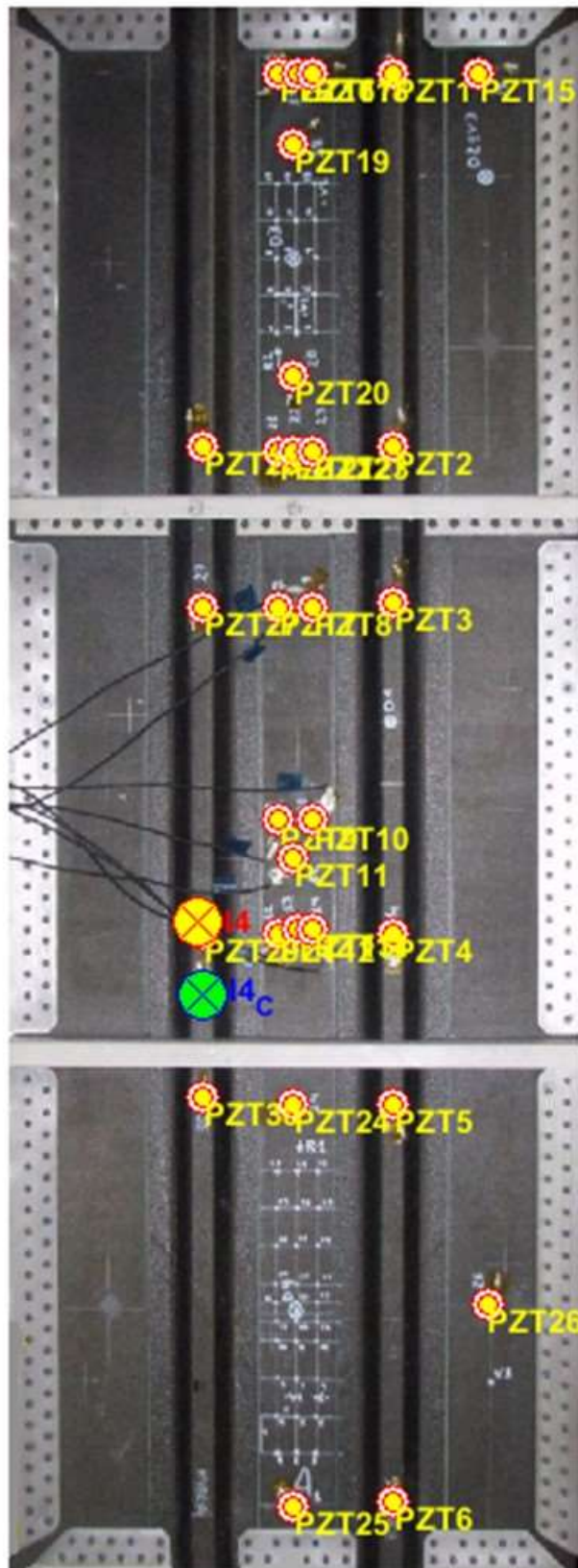

Figure 71. Damage Location I4 Impact

9 Model Validation

The computer simulation of section 8 through the developed software are validated in this section. The model validation has been achieved comparing the software results against the reliability results achieved explained in the thesis. Hence two comparisons are done. On the one hand, a comparison of the software result against manually results. On the other hand, a comparison of the 10MW Offshore Wind Turbine against other published results of the same field.

9.1 Software results against reliability results

Software results are validated against results developed through the thesis. Both methodologies are the same and both have been done based on the same inputs. It means that if the software has been developed properly, the results must be the same.

The precision through the software is higher due to all parameter can be controlled and a better accuracy is achieved.

9.2 10 MW Offshore Wind Turbine against other published wind turbine results

The model validation has been done through this section. The comparison is done between the reliability results achieved by the thesis and the published reliability results. Generally, results are quite similar. The increment on the failure rate is due to the offshore wind turbine is exposed to higher stress, loads and worse environment conditions. Reliawind Project results are based on 3-4MW onshore wind turbine. When the energy output is higher, higher failure rate should be expected.

Two scenarios have been checked:

- 1) The most frequent reliability results of the bibliography have been analyzed against our proposed offshore wind turbine. These results are shown in several publications of the field and therefore these results have been found easily and have been compared against the thesis results. [21], [20]. These results are shown in the following Figure 72, Figure 73, Figure 74, Figure 75, Figure 76 and Figure 77.

These reliability results are based on turbine of less energy output and therefore our proposed offshore wind turbine must have higher reliability. However, along the time, the quality of the components is higher and therefore higher reliability is expected. All reliability results from the bibliography shows several results for the same item depending on the data-base and the wind turbine energy output, etc.

- 2) In the section 2.1, several published reliability data-base have been analysed and through this section, the published reliability data-base are analyzed against our proposed wind turbine. These data-base are very old and from onshore environment. These published reliability data-base are shown in the following Table 44. Through this table, how old is the data-base and the energy output of the wind turbine can be seen. There are gaps into several

components due to depend on the wind turbine configurations, these turbines cannot have these specific components and therefore not information can be provided.

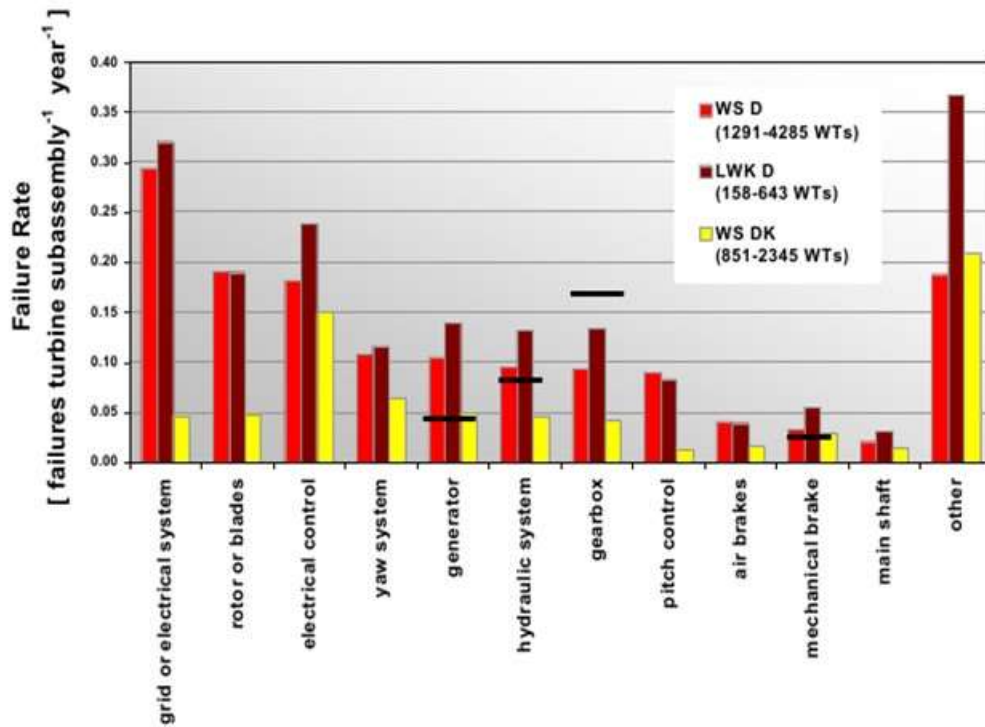

Figure 72. Reliability Results from literatura review

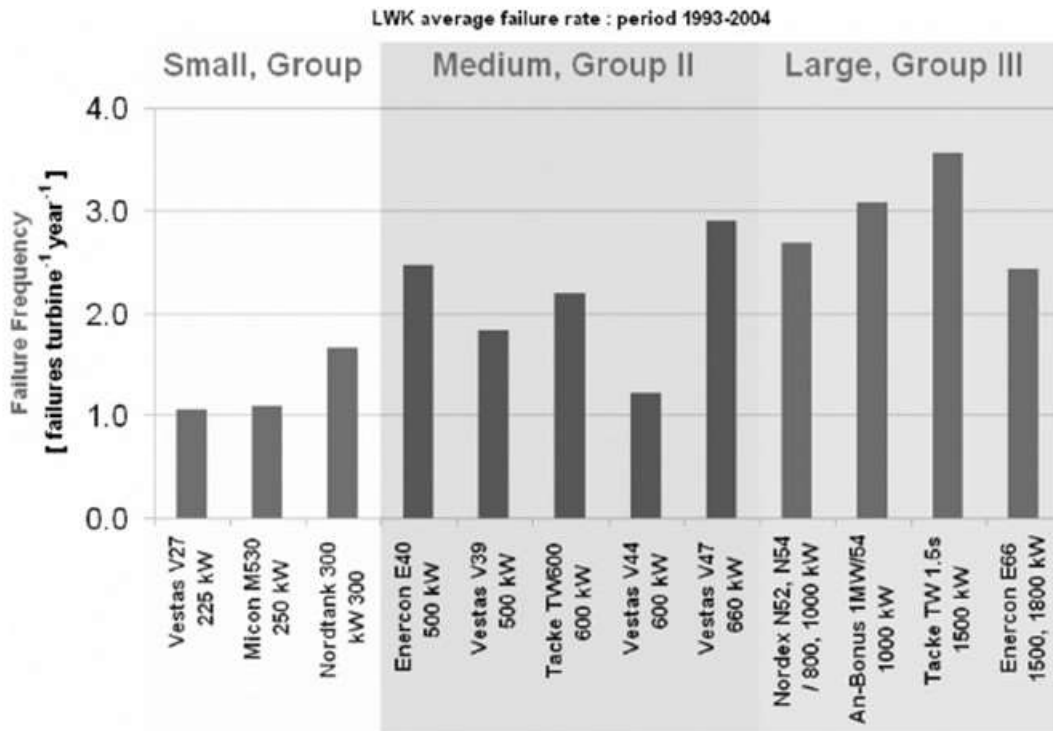

Figure 73. Reliability Results from literatura review

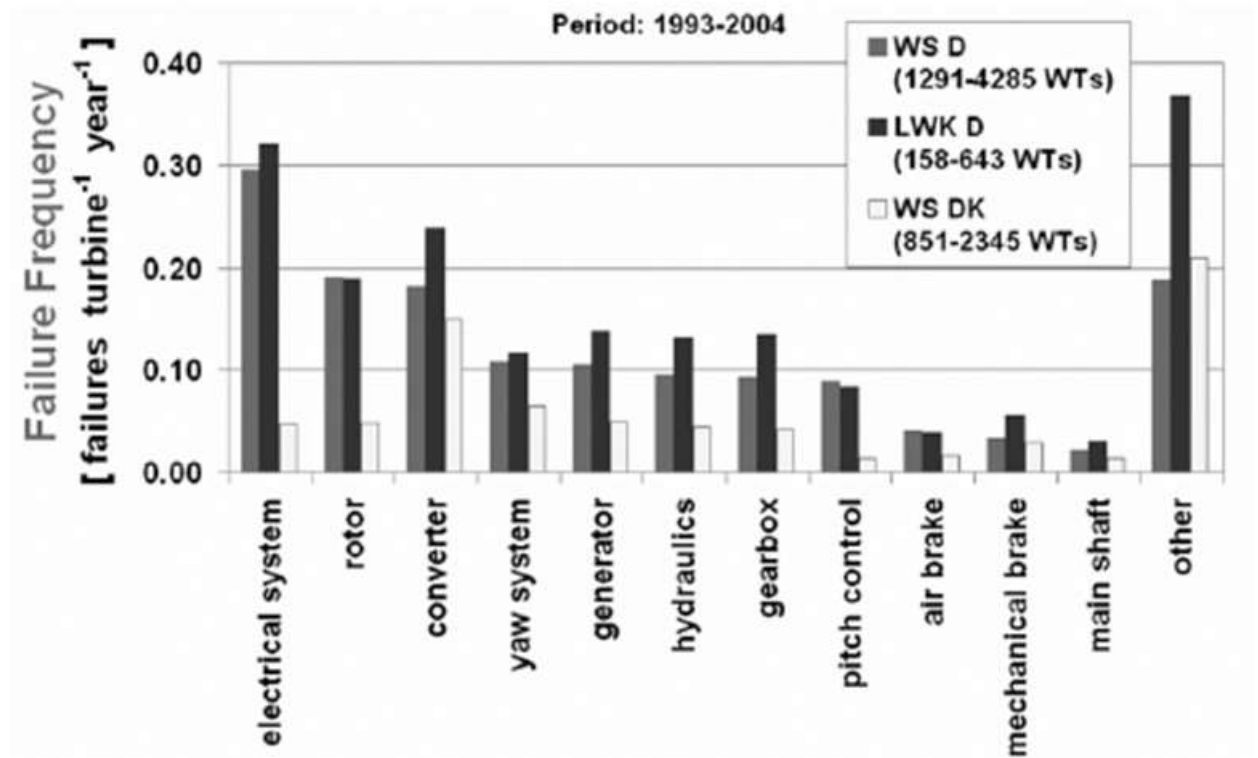

Figure 74. Reliability Results from literatura review

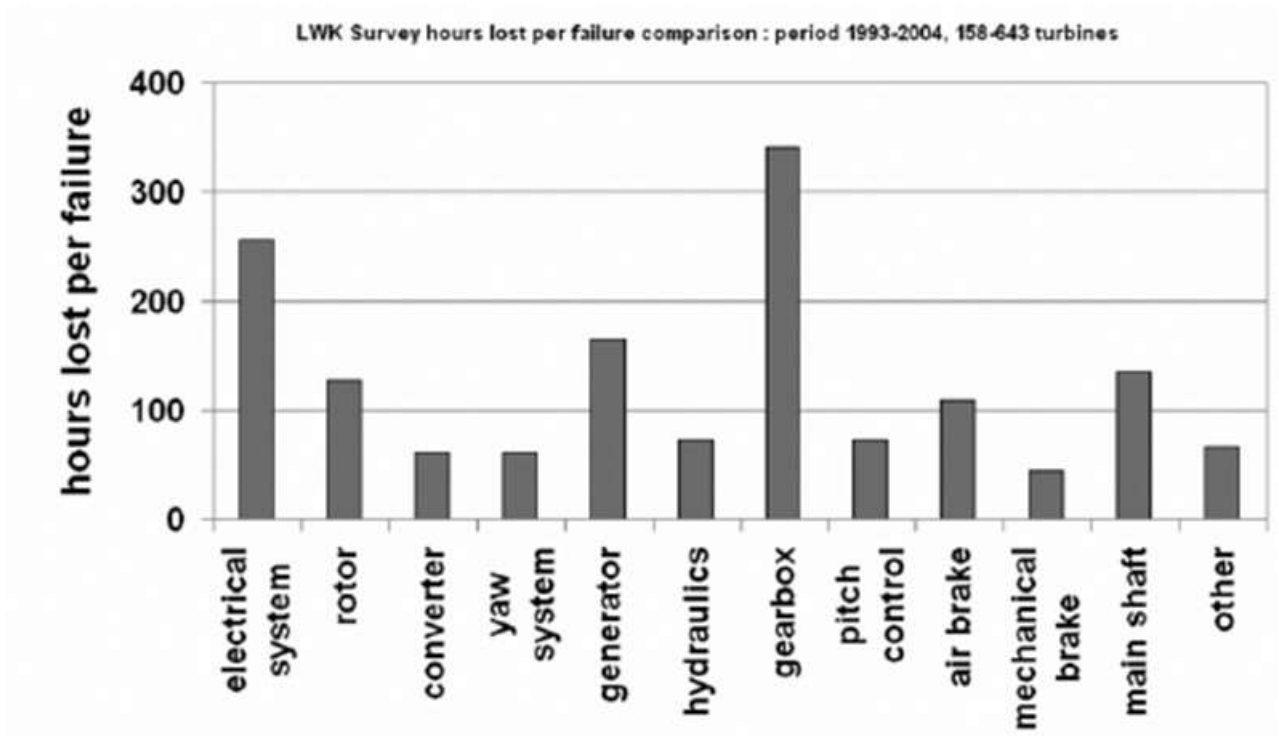

Figure 75. Reliability Results from literatura review

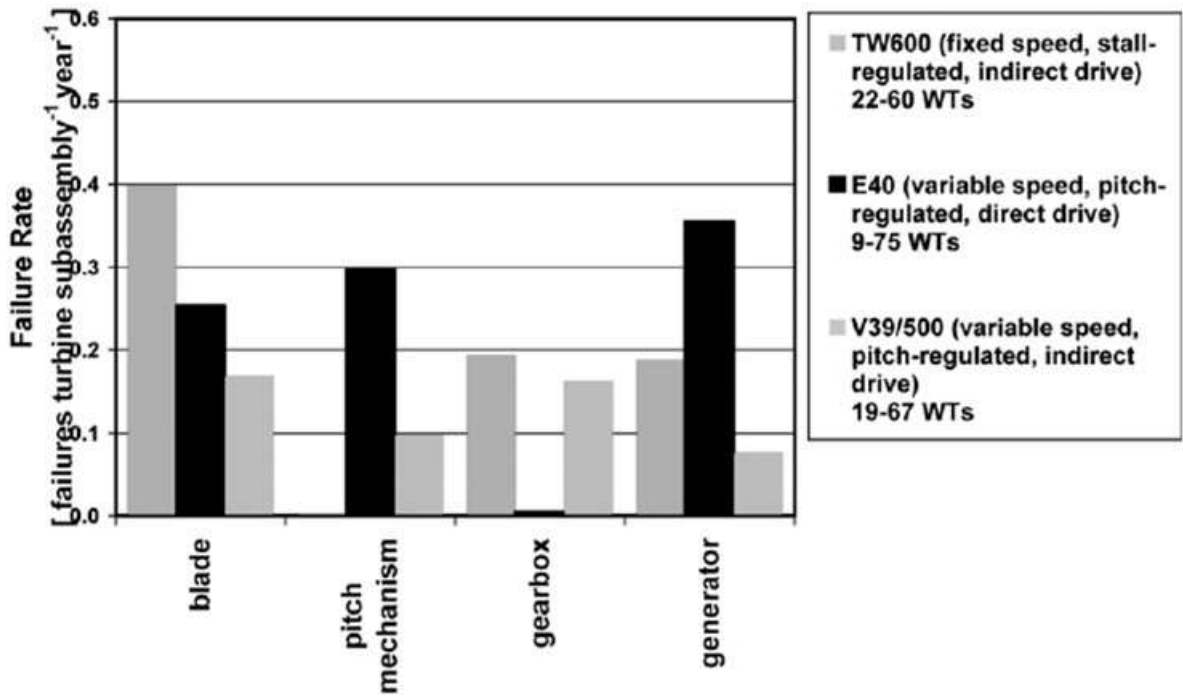

Figure 76. Reliability Results from literatura review

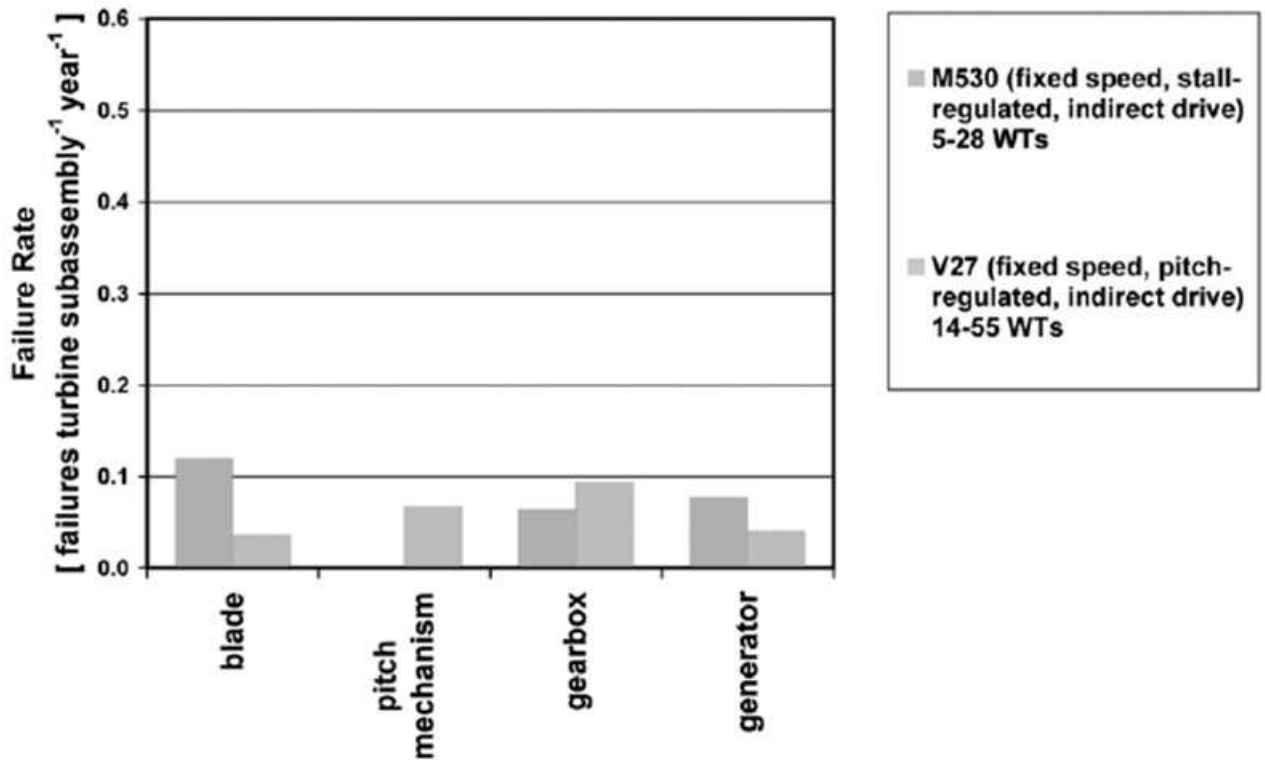

Figure 77. Reliability Results literature review

Looking deeply in the Table 44 and the Figure 72, Figure 73, Figure 74, Figure 75, Figure 76 and Figure 77 against the reliability results of the proposed 10MW offshore wind turbine, several conclusions come out such as:

- General conclusions: great dispersion between the published reliability data bases can be seen into the Table 44 and the Figure 72, Figure 73, Figure 74, Figure 75, Figure 76 and Figure 77. For the same component, the failure rates change notably
- Yaw system: the conclusions obtained by the thesis point out a failure rate equal to 0,35 per year. The literature shows a failure rate of 0.05-0.12 per year. There are several types of yaw system (hydraulic and with motor). The hydraulic yaw system has higher reliability against the one moved with motor. Our proposed wind turbine is bigger than the onshore wind turbine coming from the published data-base. It implies higher loads to be moved and therefore the probability of failure is higher.
- Gearbox: the studied gearbox points out a failure rate equal to 0.22 per year, see Figure 28 and Figure 29. Instead, the literature review shows a failure rate equal to a failure rate of 0.14-0.2 per year depending on the kind of gearbox. These results could be similar depending on the type of gearbox. Obviously, 0.14 failures per year against 0.22 failure per year is not similar and it must depend on the type of gearbox or turbine. However, 0,22 failures per years is a very low failure rate. This low failure rate is kept due to a great maintenance labour and predictive maintenance. The gearbox could be monitored through well proud methodologies of vibrations.
- Pitch system: The pitch system presents not similar results. On the one hand, our conclusions point out a failure rate of 0,706 per year. On the other hand, the bibliography a failure rate of 0.05-0.3 per year depending of the pitch system type and it is far away to our conclusions. The hydraulic pitch system is the most reliable pitch system against electrical for example. Our conclusions are based on 3 pitch systems, each one for a blade. From the published reliability data-base, the number of pitch system analyzed is not known.
- Failure rates of blades, hub, brake and main shaft are quite similar.
- Converter: failure rate of converter is very similar against the failure rates of the bibliography. There are lower and higher failure rates but the average failure rate is similar against our reliability results.
- Rotor: our reliability study points out a failure rate value of 1.064 failure per year, see Figure 28 and Figure 29. Instead, published reliability results show an average failure value of 0.32 failures per year. It is coherent due to the higher energy output and dimensions of the wind turbine which generate higher stress in out reference turbine. Moreover, the rotor failure rate of the proposed offshore wind turbine is taken into account the pitch system and blades failure rates. Besides, failure rate of 3 pitch system and 3 blades are presented. Due to the lack of information of the published reliability data base, this could be the problem of the higher failure rate of the proposed 10 MW offshore wind turbine.

Tower	-	-	-	-	-	-	-	-	-	0,2728
Grid	-	-	-	-	-	0,01	-	-	-	-
Other	0,255	0,295	-	-	0,3	0,2	2,552	-	-	-
Entire Nacelle	-	-	0,1	0,2	-	0,01	0,093	0,006	0,0079	-
Entire Turbine	-	-	-	-	-	0,06	0,033	0,011	0,0143	-
WHOLE TURBINE	1,7458	1,94	2,78	5,235	4,6	0,71	3,427	0,45	0,6028	

Table 44. Failure rate literature review

10 Conclusions

The reliability analysis for a 10MW offshore wind turbine has identified which subsystems, assemblies and sub-assemblies have a high failure rate. The subsystems with highest failure rate are Rotor Module, and Drive Train Module. In particular, the Rotor Module is exposed to high stress and fatigue during its operation time due to uneven high air pressure around it. It should be also noted that the gearbox does not appear to be one of the less reliable assemblies of an OWT as it might be expected. The RBD shows an OWT failure rate of 2.37 failures per year, which is about twice as large as an onshore wind turbine failure rate. This value could be accepted for an onshore wind turbine; however, it is a high failure rate for an OWT due to the limited accessibility to perform preventive or corrective maintenance.

The huge dimensions of the wind turbine, its complexity and the environment increase the failure rate of the system. Through quality improvements of components, and by using condition monitoring on critical assemblies, the downtime can be reduced—allowing for an accurate scheduled maintenance to be developed.

Nowadays, availability improvements have been sought, in order to reduce energy losses and make offshore wind energy more profitable. In general, commercial offshore wind turbines can achieve an availability value of about 90 %, but, depending on the maintenance assumptions, this value can increase to 95%.

However, in this analysis, logistic delays, maintenance delays and supply delays have not been taken into account; therefore, an availability value (inherent availability) of 99% has been achieved.

FMECA is performed to evaluate how to improve the reliability and maintainability (maintenance procedures) of an OWT, for which maintenance plays a really important role in terms of cost-availability. Thus, from the results that have been obtained, it can be deduced that:

- High values of frequency make the failure modes riskier, even if their end effects do not have a high severity.
- The main failure mode causes are due to the adverse environment and the huge dimension of the system.
- Mode criticalities graph and RPN graph give different lists of the riskiest failure modes of the OWT. The reason of these two points of view are that, the first one focuses the importance on the probability of occurrence while the other concerns to detection parameter combined with severity and occurrence.

Regarding the FMECA results, the attention must be paid to those failure modes whose risk is the highest. Since it has been seen that some points of view can be assumed, for next steps of RCM it will be used a combination of both lists in order not to leave any important failure mode out of consideration.

The change in environment increases the probability of certain failures, directly or indirectly. For the Rotor Module and the Structural Module, the analysis confirms that their failures are mainly caused by the hazardous environment. For the Drive Train Module and Rotor Module, the abrupt changes in wind direction lead to continuous variation on their load conditions, and consequently cause stress and fatigue. As the OWT usually works in extreme temperature conditions, the Air

Conditioning Equipment has to increase its power to maintain suitable environmental conditions, and this leads to an increase in its failure rate.

From the result of the RPN and Mode Criticalities analysis, it can be seen how each method can give different lists of riskiest parts of the system; for this reason, both analysis are suggested in order not to leave any important failure mode out of consideration.

A successfully scheduled PM program can reduce maintenance costs and increase the availability of the OWT without risks for the system, personnel or environment. Throughout the packaging study, it has been seen that clear criteria combined with expert engineering judgment can make the process much easier.

The fact that the wind turbine is placed in an offshore environment affects the PM program due to drawbacks such as limited labour hours, expensive transport, expensive maintenance tasks, the difficulty to proceed with certain corrective actions, and the difficulty to perform some preventive tasks, amongst other factors. Nonetheless, with the right tools and procedures, offshore wind can be made more reliable and feasible along the time.

Wind turbine blades are the riskiest and the most expensive component of the offshore wind turbine. The offshore environment makes that worse. Therefore, a structural health monitoring system must be applied to this part. Blades are made by composite material and the methodologies in composite materials are not clear yet. A wide range of SHM techniques can be chosen but guided waves technique has been selected to monitor the blades. SHM equipment are very expensive but the profitability of the investment is guaranteed due to the high cost that can involve the blade repair as has been checked.

In order to cover deficiencies of the Preventive Maintenance, the Condition Based Maintenance is developed. The CBM is based on a SHM system which is developed through two levels:

- Estimate the usage monitoring against a reference.
- Diagnosis of the blades which is the current condition of the blades. It is the process to identify the damage presence and quantify the damage event based on measures of the blades response.

The diagnosis is divided into several levels: damage detection, location of the damage and assessment. The methodology is checked through a composite material panel test. The test conditions are very convoluted and it can resemble the blades real state conditions. However, the damage detection and location results are accurate through a basic statistic method. The temperature effects (signal delays) have been taken into account due to the changing temperature environment. This SHM system is in charge of the diagnosis of the system, pointing out the current state condition of the blades. These conclusions are coming from the SHM system developed.

The SHM systems has to fulfil 9 levels in order to be ready to operate in an operational offshore wind turbine. Through this shown test, the SHM system has achieved the 4 level and the next level will be to test the methodology in a real offshore wind turbine blade. The quality of the SHM system results are evaluated separately:

- Damage detection: the damage detection has achieved good results and has been more difficult for the very low energy hammer impacts. Problems come through the DI comparisons. The comparison must be too much restrictive and has to be studied for more cases in order to update and to perfect the comparison.
- Damage location: The average error is 31 ± 13 mm in X axes and 38 ± 71 mm in Y axes. It has to be tested with a sparse PZT sensor network in order to check the results. Concluding, the methodology is feasible.

Through the usage monitoring and diagnosis, the prognosis is estimated. The prognosis estimates how much the system is operational and when the failure could be critical for the system. Then these prognosis conclusions are assembled and packed into the CBM through maintenance tasks. These tasks are at the right time for the state condition of the blades and therefore always improve the maintenance tasks and increasing the profits.

The PM and the CBM work together. The PM assigns the scheduled tasks and CBM takes decisions for on condition tasks. Along the time, CBM could suggest to change the PM's scheduled tasks, increasing the profits of the offshore wind energy due to the maintenance costs are reduced.

Summarizing, the offshore wind turbine is analyzed starting from the design and ending up with the two maintenance plans. The exposed Condition Based Maintenance contributes to the innovation and knowledge and it is the best way to reduce the maintenance cost, increasing the profits of the offshore wind energy.

11 Bibliography

- [1] RAC, "System Reliability Toolkit," *Reliability Information Analysis Center*, 2016.
- [2] EWEA, "The Economics of Wind Energy," 2009.
- [3] Luca Barbati and Stefano Barbati , *Common Reliability Analysis Methods and Procedures, D.2.0.1.*: Relex Italia- Reliawind Project.
- [4] Luca Barbati and Stefano Barbati , *Whole System Reliability Model (Appendixes).*: Reliawind Project, 2011.
- [5] Luca Barbati and Stefano Barbati , *Whole System Reliability Model, D.2.0.4.a.*: Reliawind Project, 2011.
- [6] Luca Barbati , *Design for Reliability FMECA Study.*: EWEA event. Relex Italia Reliawind Project, 2010.
- [7] Luca Barbati , *Functional Block Diagrams Specifications.*: Reliawind Project, 2011.
- [8] Alejandro Sanchez Sanchez , Itamar Esdras Martinez Garcia , and Emiliano Mucchi , "Reliability Prediction and Reliability Block Diagram of Offshore Wind Turbine," in *EWEA 2015 Paris Wind Energy Event*, Paris, 2015.
- [9] Alejandro Sanchez Sanchez , Itamar Esdras Martinez Garcia , and Emiliano Mucchi , "Reliability and Failure Mode Analysis of an Offshore Wind Turbine," in *Quinta Giornata de Studio Ettore Funaioli*, Bologna, 2015.
- [10] Alejandro Sanchez Sanchez , Itamar Esdras Martinez Garcia , and Stefano Barbati , "Reliability and Preventive Maintenance," in *MARE-WINT NewMaterials and Reliability in Offshore Wind Turbine Technology.*: Springer, 2016, pp. 233-272.
- [11] Christian Bank et al., "Description of the DTU 10 MW Reference Wind Turbine," *DTU University*, 2016.
- [12] SINTEF, *OFFSHORE RELIABILITY DATA 5TH EDITION VOL 1.*: OREDA , 2009.
- [13] F. Spinato , P.J. Tavner , G.J.W. Van Bussel , and E. Koutoulakos , "Reliability of wind turbine subassemblies," *IET Renewable Power Generation*, 2009.
- [14] P.J. Tavner , J. Xiang , and F. Spinato , "Reliability analysis for wind turbines," *Wind Energy*, 2007.
- [15] E. Echavarria , B. Hahn , G.J.W. Van Bussel , and T. Tomiyama , "Reliability of Wind Turbines Technology Through Time," *Solar Energy Engineering*, 2008.
- [16] G.J.W. Van Bussel and M.B. Zaaijer , "Reliability, Availability and Maintenance aspects of large-scale offshore wind farms, a concepts study," 2004.

- [17] K. Smolders , H. Long , Y. Feng , and P. Tavner , "Reliability Analysis and Prediction of Wind Turbine Gearboxes," *EWECE*, 2015.
- [18] Fabio Spinato , "The reliability of wind turbines," *Durham E-Theses*, 2014.
- [19] Haitao Guo , Simon Watson , Peter Tavner , and Jiangping Xiang , "Reliability analysis for wind turbines with incomplete failure data collected from after the date of initial installation," *Reliability Engineering and System Safety*, 2008.
- [20] P.J. Tavner , G.J. Van Bussel , and F. Spinato , "Machine and Converter Reliabilities in Wind Turbines," *Conference of Power Electronics*, 2006.
- [21] P.J. Tavner and G.J.W. Van Bussel , "Reliability of Different Wind Turbine Concepts with Relevance to Offshore Application," *Wind Energy Research Group*, 2012.
- [22] Christos Kaidis , "Wind Turbine Reliability Prediction," *Wind Power Project Management*, 2013.
- [23] A. Hameed , J. Vatn , and J. Heggset , "Challenges in the reliability and maintainability data collection for offshore wind turbines," *Renewable Energy*, 2015.
- [24] Steve Buckley , "Forecasting Wind Farm Component Failures and Availability Post-Warranty," 2013.
- [25] G.J.W. Van Bussel , "Reliability, Availability and Maintenance aspects," *DOWEC*, 2009.
- [26] Jorge Martinez and Ramon Nadira , "Assesing the risj of performance based maintenance of offshore wind farm distribution systems," *Siemens Energy Inc.*, 2011.
- [27] P.J. Tavner , Y. Feng , and H. Long , "Early experiences with UK round 1 offshore wind farms," *Durham University*, 2010.
- [28] P. Kuhn , P. Lyding , and S. Faulstich , "Reliability Data for Wind Turbine Standardization of Data Collection for Wind Turbine Reliability and Operation & Maintenance Analyses," *Fraunhofer Institute*, 2013.
- [29] Yao Hsu , Wen-Fang Wu , and Yung-Chang Chang , "Reliability Analysis of Wind Turbine Towers," *Procedia Engineering*, 2015.
- [30] Wind and Water Power Program, "Offshore Resource Assessment and Design Conditions: A Data Requirements and Gaps Analysis for Offshore Renewable Energy Systems," 2012.
- [31] MIL-HDBK-217F, "Reliability Prediction of Electronic Equipment," *Military Handbook*, 1991.
- [32] ANSI, "MIL-HDBK-217 ANSIVITA," *ANSIVITA*, 2008.
- [33] OREDA, "Offshore Reliability Data," *SINTEF*, vol. Volume 2, 2009.

- [34] Michael Wilkinson , Keir Hamman , Fabio Spinato , Ben Hendriks , and Thomas Ven Delf , "Measuring Wind Turbine Reliability - Results of the Reliawind Project," *Reliawind Project*, 2011.
- [35] Paul Richardson , "Relating onshore wind turbine," *Durhman University*, 2010.
- [36] Tomas Gintautas , "Integrated system reliability analysis," *INNWIND Project*, 2014.
- [37] A. Birolini , *Reliability engineering. Theory and Practice.*: Springer , 2003.
- [38] Yao Hsu , Wen-Fang Wu , and Yung-Chang Chang , "Reliability Analysis of Wind Turbine Towers," *Procedia Engineering*, 2015.
- [39] Zafar Hameed and Jorn Vatn , "Important challenges for 10 MW reference wind turbine from RAMS perspective," *Energy Procedia*, 2015.
- [40] Patrick O'Connor and Andre Kleyner , "Practical Reliability Engineering," *Wiley*, 2013.
- [41] M.C. Eti , S.O.T. Ogaji , and S.D. Probert , "Integrating reliability, availability, maintainability and supportability with risk analysis for improved operation of the Afam thermal power-station," *Applied Energy*, 2006.
- [42] A.J. Seebregts , L.W.M.M. Rademakers , and B.A Van den Horn , "Reliability Analysis in Wind Turbine Engineering," *Microelectronics Reliability*, 2015.
- [43] Kirsten Tracht , Gert Goch , Peter Schuh , Michael Sorg , and Jan F. Westerkamp , "Failure probability prediction based on condition monitoring data of wind energy systems for spare parts supply," *CIRP Annals-Manufacturing technology*, 2013.
- [44] Sandia National Laboratories, "Wind Turbine Reliability: A Database and Analysis Approach," 2008.
- [45] VICOR, "Reliability and MTBF overview," 2010.
- [46] NSWC, "Handbook of Reliability Prediction Procedures for Mechanical Equipment ," *Logistic Techonology Support*, 2009.
- [47] Karim Bourouni , "Desalination Reverse osmosis Availability Reliability Reliability Block Diagram," *Desalination*, 2015.
- [48] Military Handbook, "MIL-HDBK-338B," *Department of Defense*, 1998.
- [49] "MIL-STD-721C," *Military Standard Reliability and Maintainability*, 1970.
- [50] G.J.W. Van Bussel , "Offshore Wind Energy, The reliability dilemma," *DELFT University*, 2002.
- [51] Jesus Maria Pinar Perez , Fausto Pedro Garcia Marquez , Andrew Tobias , and Mayorkinos Papaelias , "Wind turbine reliability analysis," *Renewable and Suitainable Energy Reviews*, 2015.

- [52] Alexander Karyotakis , "On the optimisation of operation and maintenance strategies for offshore wind farms," London, 2011.
- [53] Okronkwo Jonathan Onwukwe, "Modelling the reliability of wind turbine generators," *Major Project Report*, 2011.
- [54] Georgios Takoudis , "Development of a Monte Carlo Model for assessing offshore wind farm cable reliability and the worth of redundancy. A comparison of various collector configurations," *Energy Systems and The Environmental*, 2004.
- [55] Anmei Zhou , Dejie Yu , and Wenyi Zhang , "A research on intelligent fault diagnosis of wind turbines based on ontology and FMECA," *Advanced Engineering Informatics*.
- [56] Gionata Carmignani , "An integrated structural framework to cost based FMECA: The priority cost FMECA," *Reliability Engineering and System Safety*.
- [57] Rodriguez Souza and Alberto Jose Alvares , "FMEA and FTA analysis for application of the reliability Centered Maintenance Methodology: Case study on Hydraulic Turbines," 2007.
- [58] Mahmood Shafiee and Fateme Dinmohammadi , "An FMECA Based Risk Assesment Approach for Wind Turbine System: A comparative study of onshore and offshore".
- [59] B. J. Garrick , "The approach to risk analysis in three industries nuclear power, spacesystems and chemical process," *Reliability Engineering & System Safety* , vol. 23, no. 3, pp. 195-205, 1968.
- [60] R. De Vita , I. C. Santillo , and C. Paladino , "Contributti dei costi indotti all'analisi FMECA di guasti critici," *Atti X Canvegno Naxionale di Impiantistica Industriale*, 1995.
- [61] D. F. Montague , "Process risk evaluation-what method use? ," *Reliability Engineering and System Safety*, vol. 29, pp. 37-15, 1990.
- [62] M. Bandelloni , F. De Carlo , M. Rapaccini , and M. Tucci , "Technical and economical evaluation of FMECA methodology applied to facilities maintenance planning," *Impiantistica Italiana*, 1999.
- [63] W. Gilchrist , "Modelling failure modes and effects analysis," *International Journal of Quality & Reliability management* , vol. 10, 1993.
- [64] M. Ben-Daya and A. Raouf , "A revised failure mode and effect analysis model," *International Journal of Quality & Reliability Management* , vol. 13.
- [65] T. Montgomery , D Pugh , S. Leedham , and S. Twitcherr , "FMEA Automation for the complete design Process," *In proceedings of Annual Reliability and Maintainability Symposium* , 1996.
- [66] Li Jun and Xu Huibin , "Reliability Analysis of Aircraft Equipment Based on FMECA Method," *Physics Procedia*, 2015.

- [67] Seung Rhee and Kosuke Ishii , "Using cost based FMECA to enhance reliability and serviceability," *Journal of advanced engineering informatics*, 2003.
- [68] Anand Pillay and Jin Wang , "Modified failure mode and effects analysis using approximate reasoning," *Journal of Reliability Engineering and System Safety*, 2003.
- [69] Ford, "Failure Mode and Effects Analysis FMEA Handbook".
- [70] Ford Motor Scanner, "Potential FMEA".
- [71] H. Arabian-Hoseynabadi , H. Oraee , and P.J. Tavner , "Failure Modes and Effects Analysis (FMEA) for wind turbines," *Electrical Power and Energy Systems*, 2015.
- [72] MIL-STD-1629, "Procedure for performing a Failure Mode, Eeffects and Criticality Analysis," *Military Standard*, 1997.
- [73] Nadia Belu , Nicolea Rachieru , and Daniel Anghel , "Fuzzy Failure Mode and Effect Analysis Application to improve laser cutting process," *Advanced Material Research* , 2015.
- [74] Salman Kahrobaee and Sohrab Asgarpoor , "Risk-Based Failure Mode and Effect Analysis," *University of Nebraska*, 2013.
- [75] Marcello Braglia , "MAFMA, multi-attribute failure mode analysis," 2016.
- [76] Thomas Vehus, "Failure Modes and Effects Analysis FMEA in avionics," 1999.
- [77] EXIDA, "Failure Modes, Effects, and Diagnostic Analysis," *United Electric One Series Electronic Switch*, 2016.
- [78] TRICONEX, "FMEA for the Tricon Version 2.0," 2007.
- [79] Lawrence Wagner , "Trends in Failure Analysis," *Microelectronics Reliability*, 2015.
- [80] Andrew Kusiak and Wenyan Li , "The prediction and diagnosis of wind turbine faults," *Renewable Energy*, 2011.
- [81] NAVAIR, "Reliability Centered Maintenance Process," 2003.
- [82] NASA, "Reliability-Centered Maintenance Guide for Facilities and Collateral Equipment," 2008.
- [83] B. Kerres , K. Fischer , and R. Madlener , "Economic evaluation of maintenance strategies for wind turbines: a stochastic analysis," *IET Renewable Power Generation*, 2015.
- [84] Joel Igba , Kazem Alemzadeh , Ike Anyanwu-Ebo , Paul Gibbons , and John Friis , "A Systems Approach towards Reliability-Centred Maintenance (RCM) of Wind Turbines," *Procedia Computer Science*, 2015.

- [85] Jannie Jessen Niesen and John Sorensen , "On risk-based operation and maintenance of offshore wind turbine components," *reliability Engineering and System Safety*, 2015.
- [86] B. Yssaad , M. Khiat , and A. Chaker , "Reliability centered maintenance optimization for power distribution systems," *Electrical Power and Energy Systems*, 2015.
- [87] Ronald Graffius , "Reliability Centered Maintenance Handbook," vol. Revision 1, 2007.
- [88] Yalcin Dalgic , Iraklis Lazakis , Iain Dinwoodie , David McMillan , and Matthew Revie , "Advanced logistics planning for offshore wind farm operation and maintenance activities," *Ocean Engineering*, 2015.
- [89] Frans de Jong , "Development of a model to estimate O&M costs for onshore wind farms," *University of Technology*, 2007.
- [90] B. Maples , G. Saur , M. Hand , R. Van de Pietermen , and T. Obdam , "Installation, Operation, and Maintenance Strategies to Reduce The Cost of Offshore Wind Energy," *NREL*, 2013.
- [91] Francois Besnard , "Load and Risk Based Maintenance Management of Wind Turbines," *Chalmers University of Technology*, 2014.
- [92] Francois Besnard , "On maintenance optimization for offshore wind farms," *Chalmers University of Technology*, 2013.
- [93] Ashish Dewan , "Logistic & Service Optimization for O&M of Offshore Wind Farms," *TU Delft*, 2014.
- [94] Anton Gustavsson and Erik Nyberg , "Maintenance Optimization of Offshore Wind Power," *Chalmers University of Technology*, 2014.
- [95] Matti Scheu , Denis Matha , Matthias Hofmann , and Michael Muskulus , "Maintenance Strategies for Large Offshore Wind Farms," *Energy Procedia*, 2012.
- [96] Vestas, "Mechanical Operating and Maintenance Manual," 2008.
- [97] Vestas, "Operation & Maintenance Manual," *Wind Energy Systems*, 2006.
- [98] Bhaba Sarker and Tasnim Faiz , "Minimizing maintenance cost for offshore wind turbines following multi-level opportunistic preventive strategy," *Renewable Energy*, 2015.
- [99] Fernando Santos , Angelo Teixeira , and C. Guedes Soares , "Modelling and simulation of the operation and maintenance of offshore wind turbines," *SAGE*, 2015.
- [100] Rademarkers and H. Branm , "O&M ASPECTS OF THE 500 MW OFFSHORE WIND FARM AT NL7," *DOWEC*, 2002.
- [101] Robert Miedema , "Offshore Wind Energy Operations & Maintenance Analysis," *DGAME*, 2012.

- [102] Rebecca Martin , Iraklis Lazakis , Sami Barbouchi , and Lars Johanning , "Sensitivity analysis of offshore wind farm operation and maintenance cost and availability," *Renewable Energy*, 2014.
- [103] Kirsten Tracht , Jan Westerholt , and Peter Schuh , "Spare Parts Planning for Offshore Wind Turbines subject to Restrictive Maintenance Conditions," *IRP*, 2013.
- [104] Marco Lewandowski and Stephan Oelker , "Towards Autonomous Control in Maintenance and Spare Part Logistics ... Challenges and Opportunities for Preacting Maintenance Concepts," *Procedia Technology*, 2014.
- [105] G.J.W. Van Bussel et al., "State of the Art and Technology Trends for Offshore Wind Energy: Operation and Maintenance Issues," 2001.
- [106] Matthias Hofmann and Iver Bakken Sperstad , "Will 10 MW Wind Turbines Bring Down the Operation and Maintenance Cost of Offshore Wind Farms?," *Energy Procedia*, 2014.
- [107] Idriss El-Thalji and Erkki Jantunen , "On the Development of Condition Based Maintenance Strategy for Offshore Wind Farm: Requirement Elicitation Process," *Energy Procedia*, 2012.
- [108] Farhad Daneshjoo Hamid Reza Ahmadi, *A New Algorithm for Damage Detection in Simple Span Bridge Piers, Based on Power Spectral Density Function and Cosh Spectral Distance*. Tarbiat Modares University. s.l.: USBOA, 2012.
- [109] Gregory James Sylvester Jarmer, *Damage Detection in Plate Structures using Guided Ultrasonic Waves*.: UC San Diego Electronic Theses and Dissertations, 2013.
- [110] L Qiao, A Esmaeily, H G Melhem K. Krishnan Nair, *Structural Damage Diagnosis Using Signal Pattern-Recognition Intelligent Computing*.: Kansas State University. s.l. : ICE, May 2007.
- [111] Shamim N. Pakzad Ruigen Yao, *Data-driven methods for threshold determination in time-series based damage detection*.: Lehigh University, 2011.
- [112] Lehigh University , *Statistical Modeling Methods for Structural Damage Identification*.: Department of Civil and Environmental Engineering, Lehigh University, Bethlehem, July 2011.
- [113] Michael S. Hamada, Larry Ticknor, Brian Weaver Tom Burr, *Model selection and change detection for a time-varying mean in process monitoring*., December 2013.
- [114] Keith Worden Charles R. Farrar, *Structural Health Monitoring: A Machine Learning*. s.l.: Wiley, 2013.
- [115] Francesco Ciampa, *Structural Health Monitoring Systems for Impacted Isotropic and Anisotropic Structures*.: Bath University, May 2012.

- [116] Gyuhae Park, Joaquim Figueiras, Charles Farrar, Keith Worden. March Eloi Figueiredo, *Structural Health Monitoring Algorithm Comparisons Using Standard Data Sets.*: Los Alamos, March 2009.
- [117] Howard M. Matt, *Structural Diagnostics of CFRP Composite Aircraft Components by Ultrasonic Guided Waves and Built-In Piezoelectric Transducers.*: Los Alamos, February 2007.
- [118] Renee M. Kent, Antony Bartolini, Charles B. Gause, Jason W. Borinski, Jason Dietx, Jennifer L. Elster, Clark Boyd, Larry Vicari, Asok Ray, Eric Keller, Vadlamani, Venkata, S. C. Sastry Thomas E. Munns, *Health Monitoring for Airframe.*, February 2002.
- [119] Wenxian Yang , P.J. Tavner , and R. Court , "An online technique for condition monitoring the induction generators used in wind and marine turbines," *Mechanical System and Signal Processing*, 2015.
- [120] Roman Wisznia , "Condition Monitoring of Offshore Wind Turbines," *KTH Master of Science Thesis*, 2016.
- [121] Angel Lozano Martin , Jaime Garcia Alonso , Patricia Fernandez Lopez , Manuel Iglesias , and Alfredo Guemes , "Detection of impact damages in composite stiffened ribs by a PZT network".
- [122] Angel Lozano Martin et al., "Material elastic waves test exploitation in benefit of composite structure".
- [123] The Crow Estate, "A Guide to an Offshore Wind Farm," 2010.
- [124] Senu Sirnivas , Walt Musial , Bruce Bailey , and Matthew Filippelli , "Assessment of Offshore Wind System Design, Safety, and Operation Standards," *NREL*, 2014.
- [125] S. Tohidi et al., "Electric Power Systems Research," *Electric power Research*, 2015.
- [126] John Fletcher and Jin Yang , "Introduction to doubly-fed induction generator for wind power applications," *Paths to Sustainable Energy*, 2010.
- [127] Baku Nagai , Kazumasa Ameku , and Jitendro Nath , "Performance of a 3Â kW wind turbine generator with variable pitch control system," *Applied Energy*, 2009.
- [128] John Davidson , "The reliability of mechanical systems. John Davidson," 1994.
- [129] Nicolas Boccard , "Capacity Factor of Wind Power," 2008.
- [130] M. Ragheb , "Wind Energy Conversion Theory Betz Equation," *Wind Energie*, 2016.
- [131] Association, British Wind Energy, *Prospects for offshore wind energy: a report written for the EU.*: BWEA, 2000.

- [132] CA-OWEE, *Offshore wind energy: ready to power a sustainable Europe. Final report.*, 2001.
- [133] Department of Trade and Industry (DTI), *Future offshore: a strategic framework for the.*, 2002.
- [134] Y. Sinha and J.A. Steel , "A progressive study into offshore wind farm maintenance optimisation using risk based failure analysis," *Renewable and Sustainable Energy Reviews*, 2015.
- [135] Dennis B. Brickman and Ralph L. Barnett , "Auger Elevator-Failure Modes and Effects Case Study," *Safety Brief*.
- [136] Mohsen Akbari , P. Khazaei , I. Sabetghadam , and P. Karimfard , "Failure Modes and Effects Analysis (FMEA) for Power Transformers," 2013.
- [137] M. Entezami , S. Hillmansen , P. Weston , and M.Ph. Papaefias , "Fault detection and diagnosis within a wind turbine mechanical braking system using condition monitoring," *Renewable Energy*, 2012.
- [138] R. Errichello and J. Muller , "Gearbox Reliability Collaborative Gearbox 1 Failure Analysis Report," *NREL*, 2012.
- [139] M. koentges , "Review of Failures of Photovoltaic Modules," *Photovoltaic Power System Programme*, 2014.
- [140] D.J. Malcohm and A.C. Hansen , "WindPACT Turbine Rotor Design Study," *NREL*, 2006.
- [141] C. Mone , A. Smith , B. Maples , and M. Hand , "Cost of Wind Energy Review," *NREL*, 2015.
- [142] Renewable Advisory Board, "Value breakdown for the offshore wind sector," 2010.
- [143] R. Poore and C. Walford , "Development of an Operations and Maintenance Cost Model to Identify Cost of Energy Savings for Low Wind Speed Turbines," *NREL*, 2008.
- [144] European Wind Energy Association, "The Economics of Wind Energy".
- [145] Anders Myhr , Catho Bjerkseter , Anders Agotnes , and Tor A. Nygaard , "Levelised cost of energy for offshore floating wind turbines in a life cycle perspective," *Renewable Energy*, 2014.
- [146] Renewable Energy Technology, "Cost Analysis Series. Volume 1," *Power Sector*, 2012.
- [147] Elin E. Halvorsen-Weare , Christian Gundegjerde , Ina B. Halvorsen , Lars Magnus Hvattum, and Lars Magne Nonas, "Vessel fleet analysis for maintenance operations at offshore wind farms," *Energy Procedia*, 2013.
- [148] Christian Gundegjerde and Ina Blomseth Halvorsen , "Vessel fleet size and mix for maintenance of offshore wind farms," *NTNU*, 2012.

- [149] Renewables Advisory Board , "Value breakdown for the offshore wind sector," 2010.
- [150] IRENA, "Wind Power," *International Renewable Energy Agency (IRENA)*, 2012.
- [151] L. Fingersh , M. Hand , and A. Laxson , "Wind Turbine Design Cost and Scaling Model," *NREL*, 2006.
- [152] IATA's Maintenance Cost Force, *Airlines Maintenance Cost Executive Commentary.*, December 2015.
- [153] Charles R. Farrar, Michael B. Prime, Daniel W. Shevitz Scott W. Doebling, *Damage Identification and Health Monitoring of Structural and Mechanical Systems from Changes in Their Vibration Characteristics: A Literature Review.*, May 1996.
- [154] Anne S. Kiremidjian K. Krishnan Nair, *Time Series Based Structural Damage Detection Algorithm Using Gaussian Mixtures Modeling.*, May 2007.
- [155] Mads Knude Hovgaard, *Incorporating Structural Health Monitoring in the Design of Slip Formed Concrete Wind Turbine Towers.*: Aarhus University.
- [156] Colin Michael Haynes, *Effective Health Monitoring Strategies for Complex Structures.*: University of California.
- [157] Olivier Diligent, *Interaction between fundamental lamb modes and defects in plates.*: Imperial College London, 2003.
- [158] Roger P. Dalton, *The propagation of lamb waves through metallic aircraft fuselage structure.*: Imperial College London, January 2000.
- [159] C Cabrera, P Sarabandi, K K Nair, AKiremidjian, H Wenzel A Cheung, *The application of statistical pattern recognition methods for damage detection to field data.*, January 2008.
- [160] Mahmood Shafiee , "Review Maintenance logistics organization for offshore wind energy: Current progress and future perspectives," *Renewable Energy*, 2015.
- [161] CJ Hockley , "Wind turbine maintenance and topical research questions," *IRP*, 2015.
- [162] S Ruigen , "Autoregressive statistical pattern recognition algorithms for damage detection in civil structures," *Department of Civil and Environmental Engineering Lehigh university*, 2011.
- [163] Krishan Nair, Anne S. Kiremidjian, Allen Cheung, Pooya Sarabandi, *Aplication of Damage Detection Algorithms to Bridge Field Test Data.*